

Home > Charger/Adaptor > V-mount

MATRIX-S8 | 8x100W Ultra fast V-mount Wall Charger



- > 8-ch simultaneous fast charging
- > Charge both 14.4V and 28.8V V-mount batteries
- > 100W/6A for SWIT 14.4V & ≥160Wh batteries
- > 100W/3A for SWIT 28.8V & ≥160Wh batteries
- > 50W/3A for other batteries
- > 2x 3.5-inch color LCD info display
- > Battery cycle times display
- > Large LED charging indicators
- > Wall mounting or 19-inch rack install



MSRP Ex TAX / Shipping

Features Specifications Download What's in box Optional accessory Related



8x100W Ultra Fast Wall Charger

MATRIX-S8 is an 8-ch simultaneous V-mount wall charger with 100W ultra fast charging speed each channel, save up to 60% charging time comparing to normal chargers, supports both 14.4V and 28.8V batteries, for TV stations and rental houses installation.

Charging time comparison

Battery Capacity	160Wh	210Wh	220Wh	290Wh	420Wh
33W normal charger	6h	8h	8h 15m	10h 30m	15h
50W fast charger	4h ↓	5h 15m ↓	5h 45m ↓	7h 15m ↓	10h 10m ↓
MATRIX 100W Ultra fast charger	2h 15m ↓↓	3h ↓↓	3h 20m ↓↓	3h 50m ↓↓	5h 20m ↓↓

↓↓ Save up to 60% charging time



Flexible Wall Mounting Plate

MATRIX-S8 provides with a wall mounting plate on the backside, to be screwed onto the wall, or mounting to standard 19-inch rack bracket. You can even install the mounting plate onto storage rack or DIT cart.

3.5-inch Color LCD and Indicators

MATRIX-S8 provides 2x 3.5-inch color LCD to display charging progress, charging current, voltage, battery cycle times for each channel. You can also check the charging status by large charging indicators from a distance.



SWIT Electronics Europe GmbH

Heerdterbuschstrasse 10 / HALLE 9,
41460 Neuss, NRW Germany
VAT: DE308323924
WEEE-Reg.-Nr. DE 37399843
Email: info@swit-europe.com

Email Newsletter

Please enter Email address below and subscribe our newsletters.

submit

Privacy Policy

leave a message

SWIT®

MATRIX-S8

8×100W Ultra Fast Wall Charger

Charge both 14.4V and 28.8V batteries

SAVE 60% CHARGING TIME

Wall / Bracket Mounting

MATRIX-S8 provides a wall mounting plate to be screwed onto the wall, or mounting to standard 19-inch rack bracket. You can even install the mounting plate onto storage rack or DIT cart.

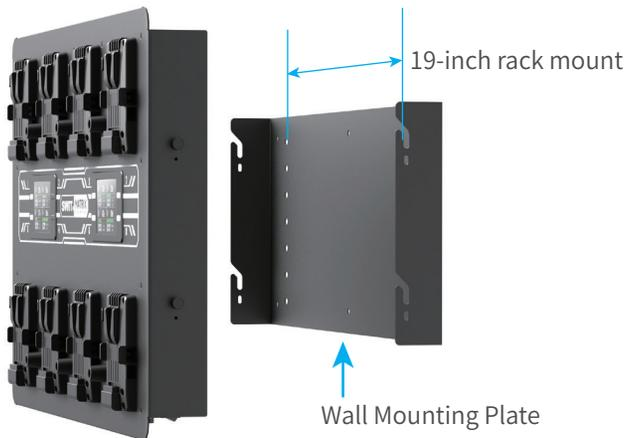

3.5-inch LCD and Indicators

Ready for mounting battery

Charging Status
Percentage / Current / Voltage

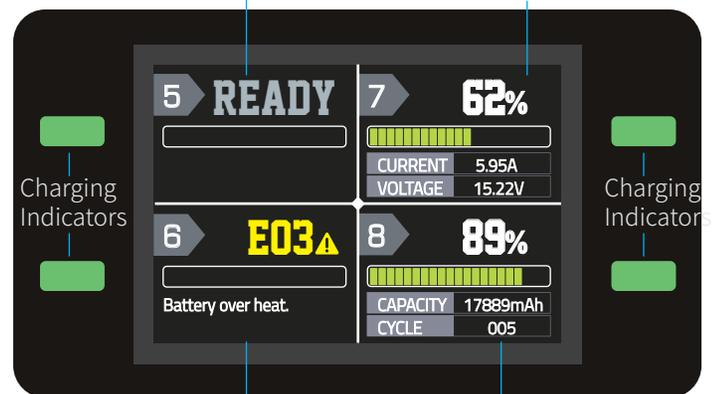

Charging abnormal Warning
(Following on-screen instructions to take steps)

Charging Status
Realtime Capacity / Cycle times

8×100W Ultra Fast Charging

Charge both 14.4V and 28.8V V-mount Batteries

Battery Capacity	33W Charger	50W fast Charger	100W Ultra Fast MATRIX
160Wh	6h	4h ↓	2h 15m ↓↓
210Wh	8h	5h 15m ↓	3h ↓↓
220Wh	8h 15m	5h 45m ↓	3h 20m ↓↓
290Wh	10h 30m	7h 15m ↓	3h 50m ↓↓
420Wh	15h	10h 10m ↓	5h 20m ↓↓

Specifications

Model	MATRIX-S8
Type	V-mount
Input	100~240VA, 50/60Hz
Power	900W (Max)
Charging output	DC 16.8V, 6A (100W)×8 (SWIT 14.4V & ≥160Wh batteries) DC 33.6V, 3A (100W)×8 (SWIT 28.8V & ≥160Wh batteries) DC 16.8V, 3A (50W) ×8 (Other batteries)
Dimensions	630×436×89mm
Net weight	Approx. 10.6kg

SWIT Electronics Co., Ltd.
+86-25-85805753
<http://www.swit.cc>
Email: contact@swit.cc

SWIT Electronics America, Inc
1-(408)260-8258
<http://www.switusa.com>
Email: info@swit.us

SWIT Electronics Europe GmbH
+49(0)21316632331
<http://www.switeu.com>
Email: info@swit-europe.com



Facebook Page



Instagram

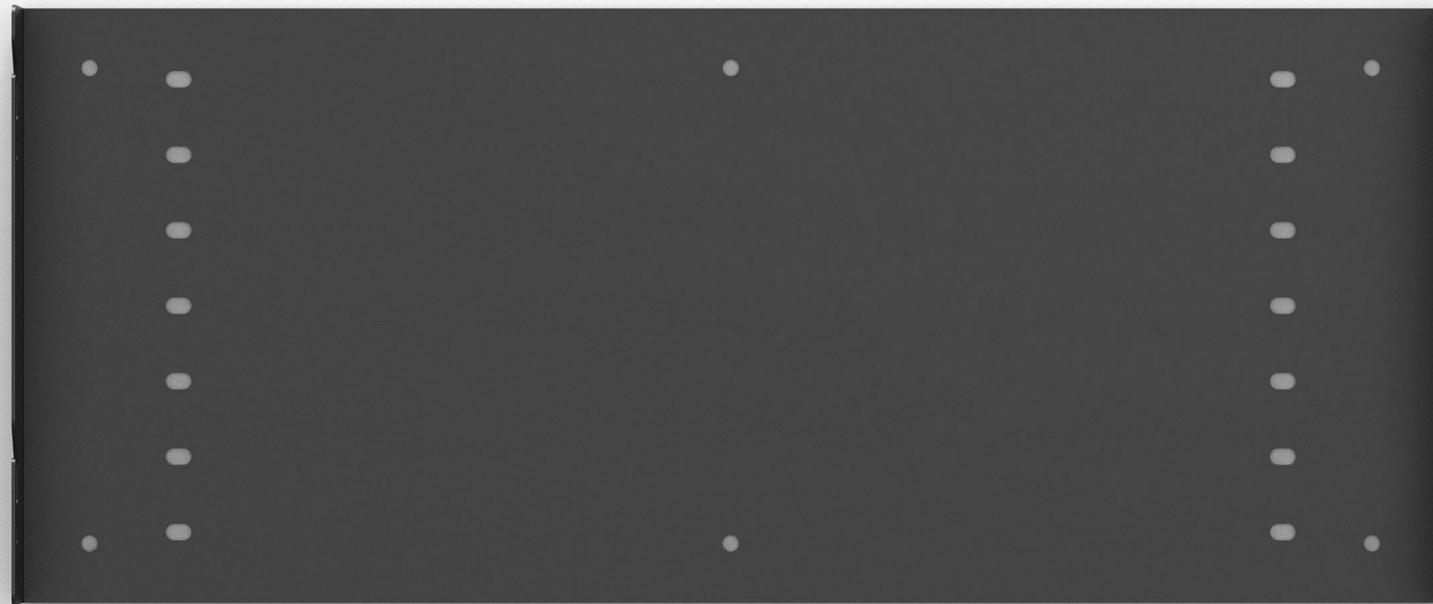

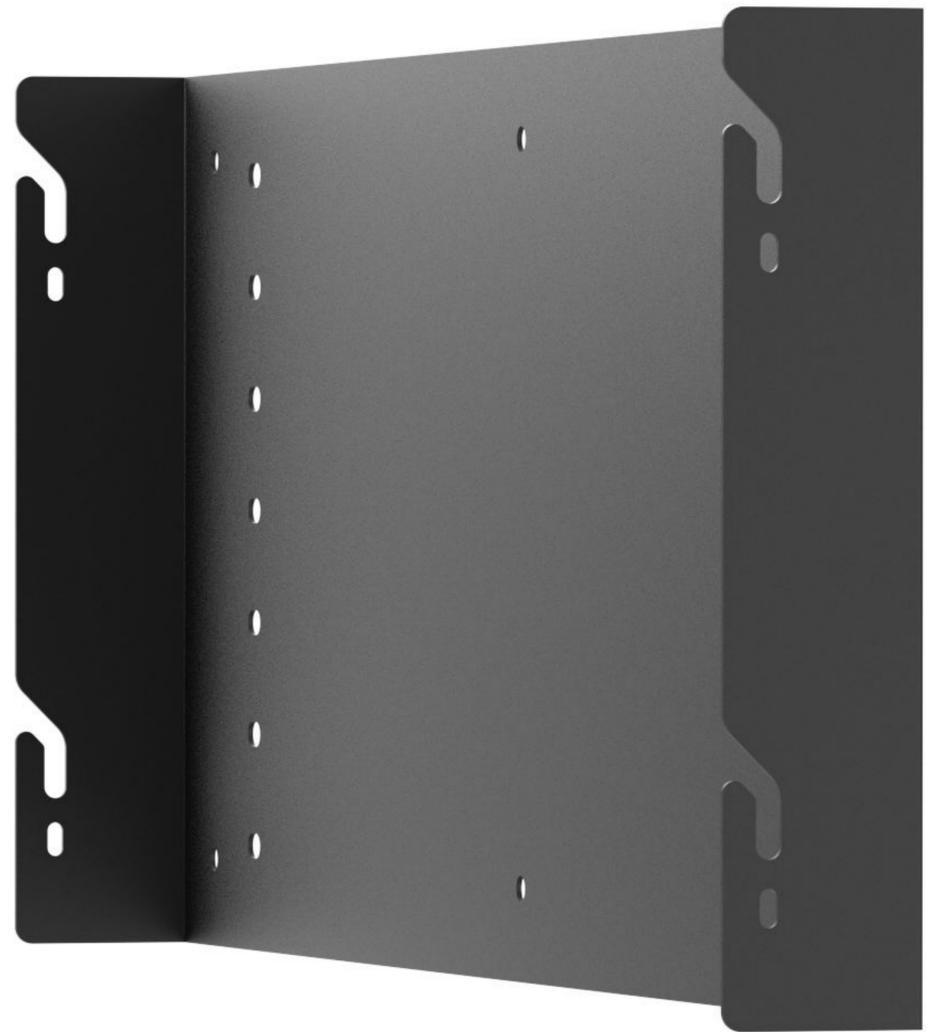



SWIT®

PB-C420S

14.4V, 420Wh / 29.4Ah

Li-ion Battery Pack

420

250W/20A HIGH LOAD CHARGE POWER

CE UK CA UN38.3 MSDS USER MANUAL DOWNLOAD

SWIT Electronics Co., Ltd.

SWIT®

PB-C420S

14.4V, 420Wh / 29.4Ah

Li-ion Battery Pack

420

250W/20A HIGH LOAD CHARGE POWER

CE UK CA UN38.3 MSDS USER MANUAL DOWNLOAD

SWIT Electronics Co., Ltd.

SWIT®

HB-C420S

28.8V, 420Wh / 14.7Ah

Li-ion Battery Pack

420 28.8V

600W/20A HIGH LOAD CHARGE POWER

CE UK CA UN38.3 MSDS USER MANUAL DOWNLOAD

SWIT Electronics Co., Ltd.

SWIT®

HB-C420S

28.8V, 420Wh / 14.7Ah

Li-ion Battery Pack

420 28.8V

600W/20A HIGH LOAD CHARGE POWER

CE UK CA UN38.3 MSDS USER MANUAL DOWNLOAD

SWIT Electronics Co., Ltd.

1	29%	3	62%
CAPACITY	4583mAh	CURRENT	5.95A
CYCLE	029	VOLTAGE	15.22V
2	37%	4	89%
CURRENT	5.95A	CAPACITY	17889mAh
VOLTAGE	14.67V	CYCLE	005

SWIT® MATRIX

8*100W Ultra Fast Charger

5	33%	7	52%
CAPACITY	4583mAh	CURRENT	5.95A
CYCLE	029	VOLTAGE	15.22V
6	42%	8	89%
CURRENT	5.95A	CAPACITY	17889mAh
VOLTAGE	14.67V	CYCLE	005

SWIT®

PB-C420S

14.4V, 420Wh / 29.4Ah

Li-ion Battery Pack

420

250W/20A HIGH LOAD CHARGE POWER

CE UK CA UN38.3 MSDS USER MANUAL DOWNLOAD

SWIT Electronics Co., Ltd.

SWIT®

PB-C420S

14.4V, 420Wh / 29.4Ah

Li-ion Battery Pack

420

250W/20A HIGH LOAD CHARGE POWER

CE UK CA UN38.3 MSDS USER MANUAL DOWNLOAD

SWIT Electronics Co., Ltd.

SWIT®

PB-R160S+

14.4V, 160Wh / 11.1Ah

IP54 Rainproof

Heavy Duty Li-ion Battery

160

200W/16A HIGH LOAD CHARGE POWER

CE UK CA UN38.3 MSDS USER MANUAL DOWNLOAD

SWIT Electronics Co., Ltd.

SWIT®

MINO-S210

14.4V, 210Wh / 14.6Ah

Li-ion Battery Pack

200W/16A HIGH LOAD CHARGE POWER

CE UK CA UN38.3 MSDS USER MANUAL DOWNLOAD

SWIT Electronics Co., Ltd.

