

# BM-H215 | 21.5-inch 4K Input Ready Production Monitor

- 21.5-inch 1920x1080 QLED Panel
- 100% DCI-P3 wide color gamut coverage
- VICO 1.97 A-class Eye Protecting LCD
- 12GSDI, 4x3GSDI, HDMI2.0 4K input
- 4-ch SDI/HDMI mixed input
- 2-ch SDI/HDMI PBP or PIP view
- Multi Color Gamut & HDR/SDR Viewing
- Payload ID auto setting
- 18-bit internal color processing
- Audio/Video Zero latency for lip-sync
- 3DLUT Auto Self-calibration without PC
- Built-in Multi camera Delog LUTs
- User 3DLUTs upload via USB
- Waveform / Vector / Histogram / Eye pattern
- Focus assist / False color / Zebra
- 16-ch audio meters / Lissajous pattern
- 5.1 & 7.1 surround sound phase pattern
- IP webserver remote control
- TSL UMD and text TALLY display
- USB firmware upgrade

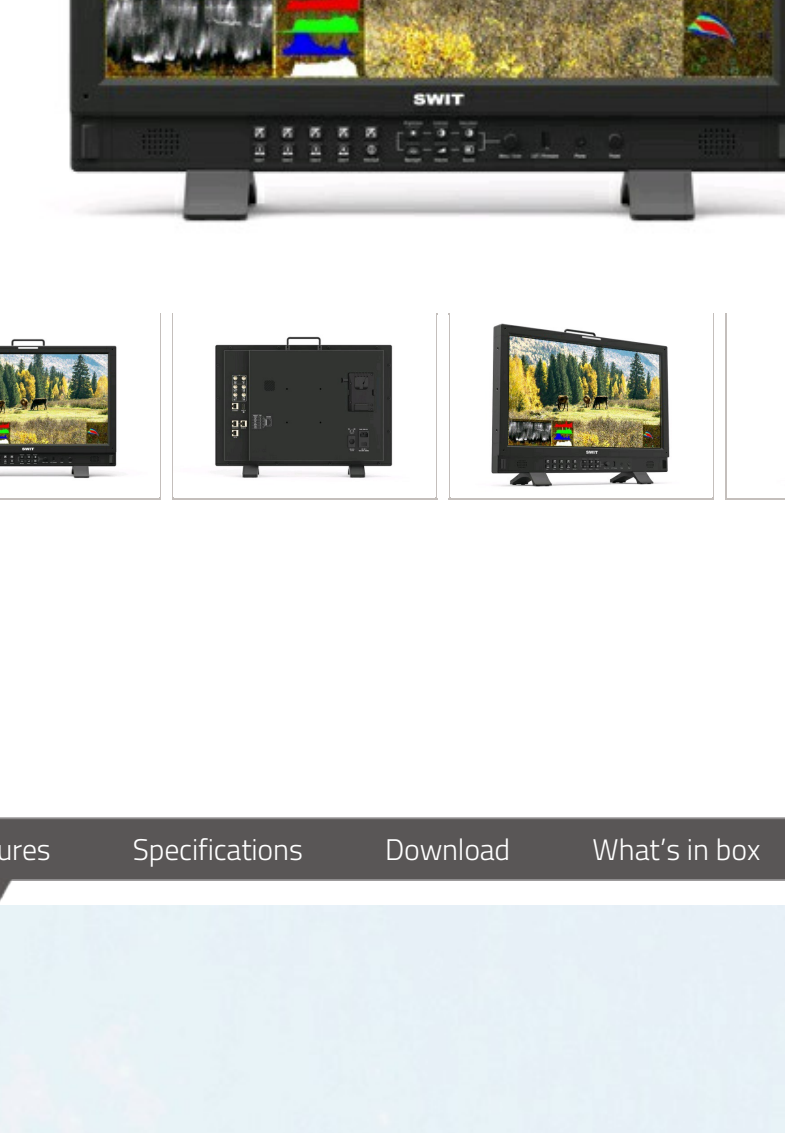

MSRP Ex Tax / Shipping

## 21.5-inch QLED WCG Panel

8-bit IPS LCD

BM-H215 adopts a 21.5-inch FHD 1920x1080 LCD panel, 8-bit 16.77M colors, 250nits, 1000:1 contrast, H/V 178° viewing angle for broadcast and film productions.



## Multi 4K Interfaces

BM-H215 provides 4x SDI inputs and 2x SDI loop outputs, supports multiple 4K inputs including:

- 12GSDI Single link 4K,
- 4x3GSDI Quadlink 4K, (SQD and 2SI)
- HDMI 2.0 (4K60P)

Supports pixel-to-pixel zoom-in the 4K signal to FHD panel.

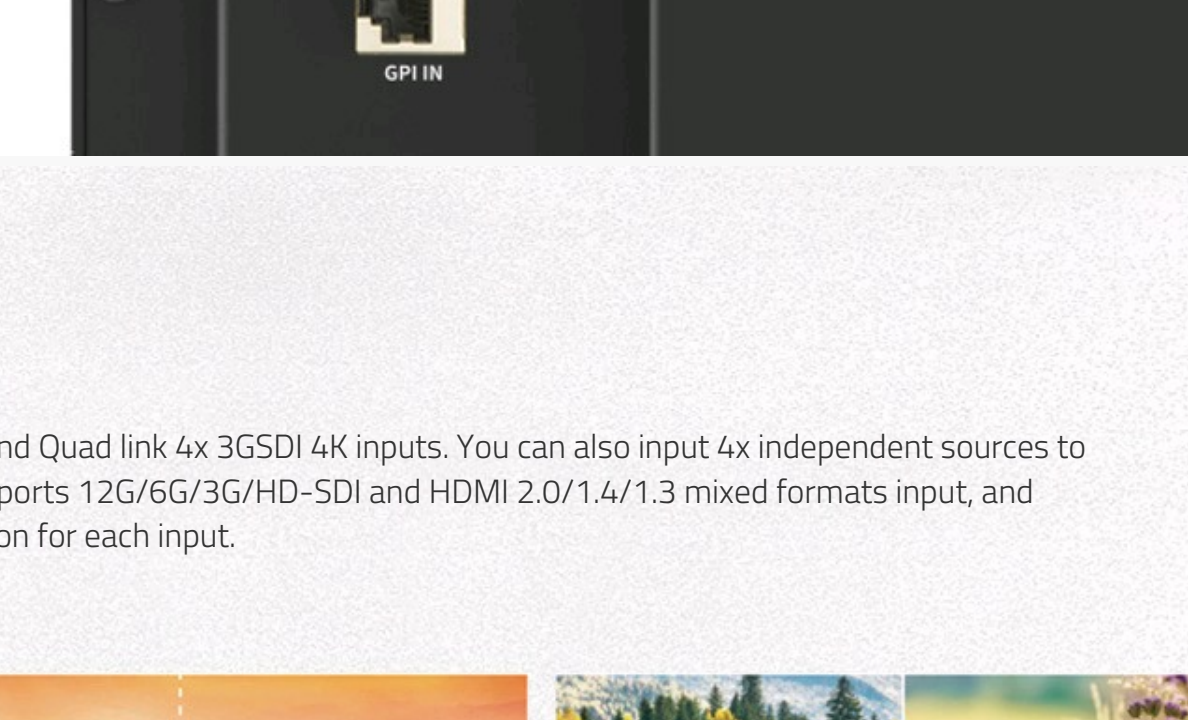

## Display Modes

Supports Single link 4K input including 12GSDI, HDMI2.0, and Quad link 4x 3GSDI 4K inputs. You can also input 4x independent video inputs of 12G/6G/3G/HD-SDI and HDMI 2.0/1.4/1.3 mixed formats input, and waveform, vector, audio meters, EOTF, color gamut selection for each input.



Single link 4K inputs - 12GSDI, HDMI2.0      Quad link 4K inputs - 4x 3GSDI (SQD or 2SI)      Mixed inputs Multiview - 4 independent video inputs of 12G/6G/3G/HD-SDI or HDMI mixed

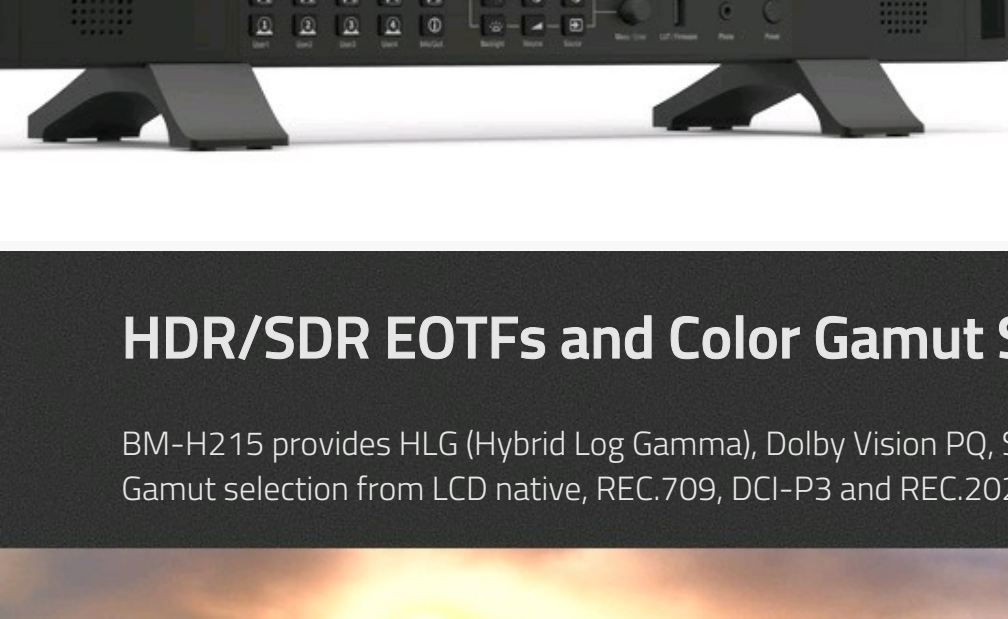

## VICO 1.97 Eye Protect

BM-H215 QLED panel has a Quantum Dot layer between LCD screen and its LED backlight, which changes the LED spectrum to reduce blue and balance the R/G/B peak, which will stimulate people's cone cells evenly, and reducing visual fatigue effectively.

The VICO (Visual Health and Comfort) testing scores 1.97, A class, to protect your eyes from long time video editing or broadcast studio productions.



Regular LED backlight 70nm half peak, high blue and Green/Red mixed      BM-H LED backlight Balanced R/G/B produces pure colors and eye protecting

## HDR/SDR EOTFs and Color Gamut Selection

BM-H215 provides HLG (Hybrid Log Gamma), Dolby Vision PQ, SONY S-Log3 HDR and Gamma 1.0/1.8/2.2/4/2.6 SDR EOTFs, and Color Gamut selection from LCD native, REC.709, DCI-P3 and REC.2020. Supports Payload ID auto set input range, HDR/SDR, Color Gamut, etc.

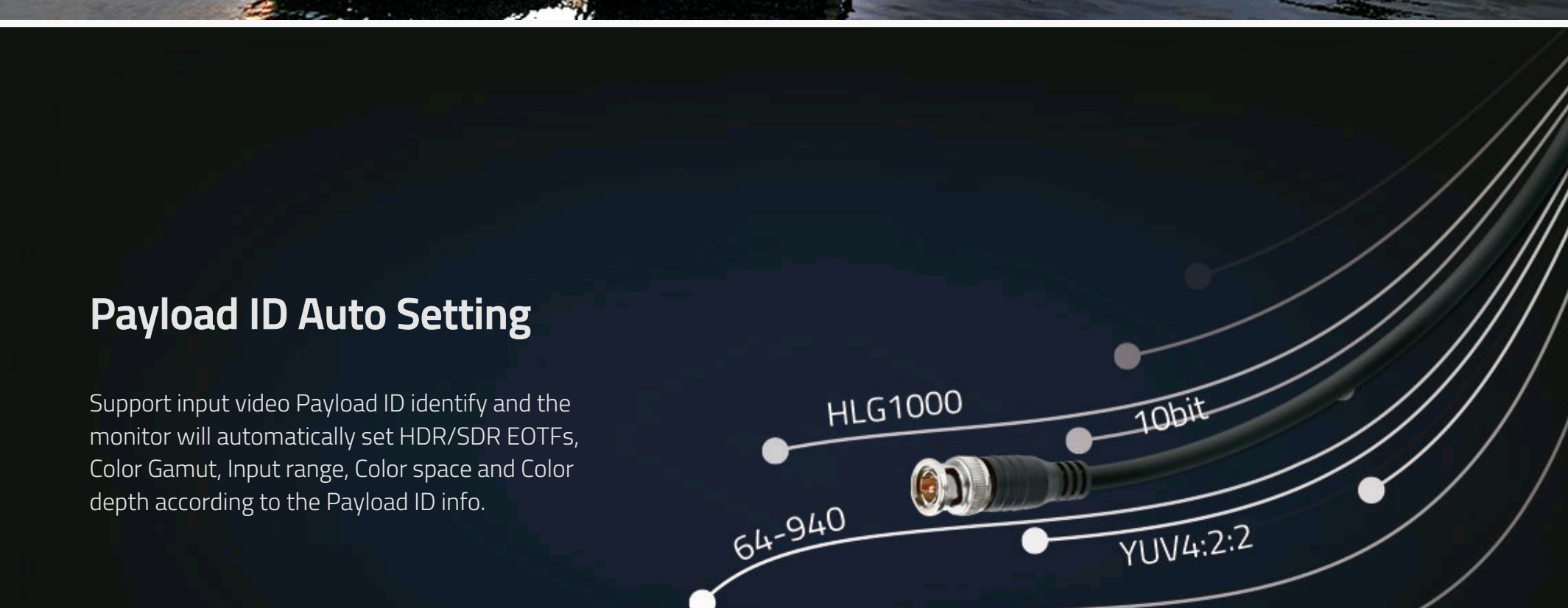

## Payload ID Auto Setting

Support input video Payload ID and the monitor will automatically set HDR/SDR EOTFs, Color Gamut, Input range, Color space and Color depth according to the Payload ID info.

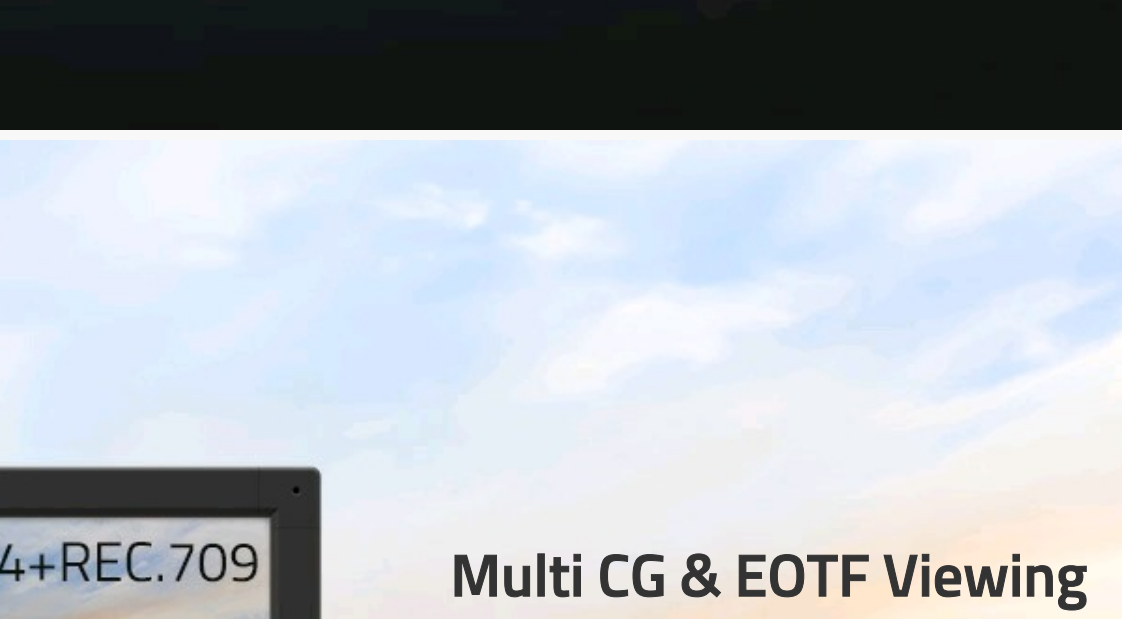

## Multi CG & EOTF Viewing

Supports 1 input source copied to 4 windows and display different HDR/SDR and color gamut simultaneously. You can get correct reference when producing HDR and SDR together.



## 3DLUT Auto Self-Calibration

By X-rite i1 or JETI Specbos 1211

With built-in 3DLUT calibration software, (software copyright) support X-rite i1 and Jeti Specbos 1211 probes to directly connect with the monitor USB port. The monitor generates color patterns and the color probes read the color, send color info to monitor via USB. Then the monitor compares the color difference and generate 3DLUT and calibrate itself automatically. Calibration time: X-rite i1 15min, Specbos 1211 45min Calibration result: ΔE≤1.0

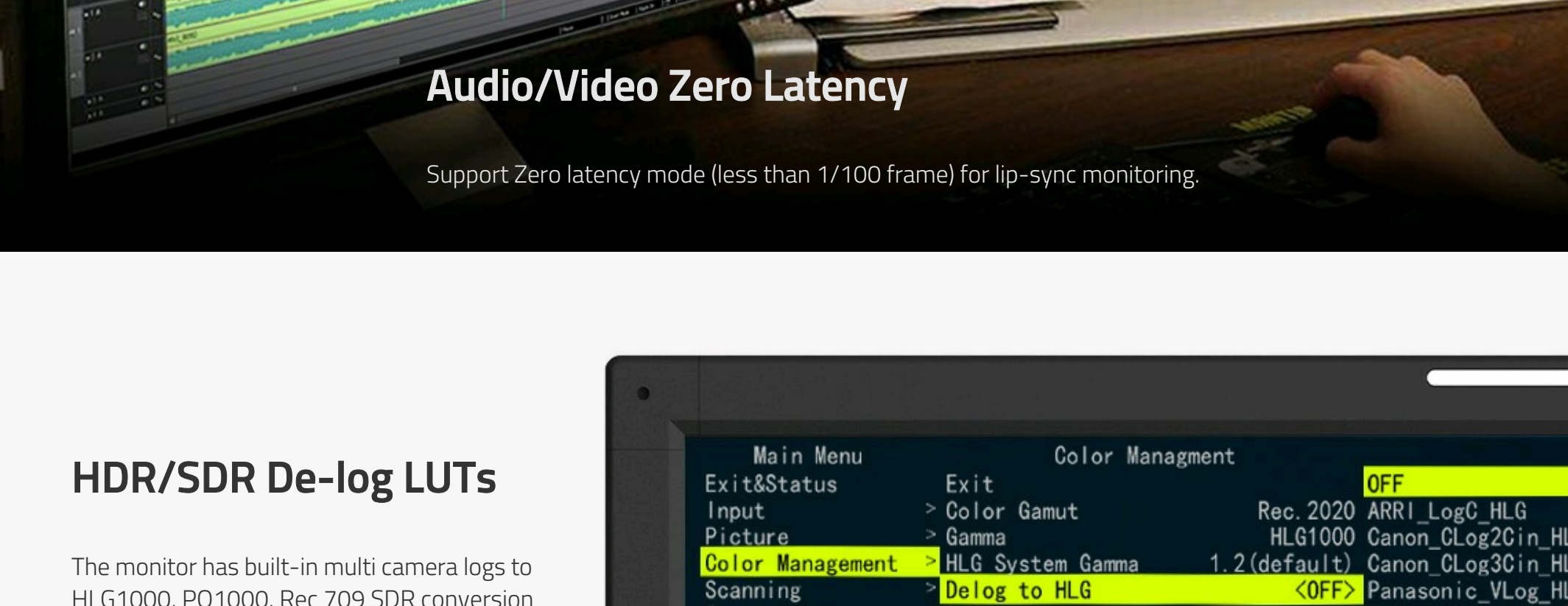
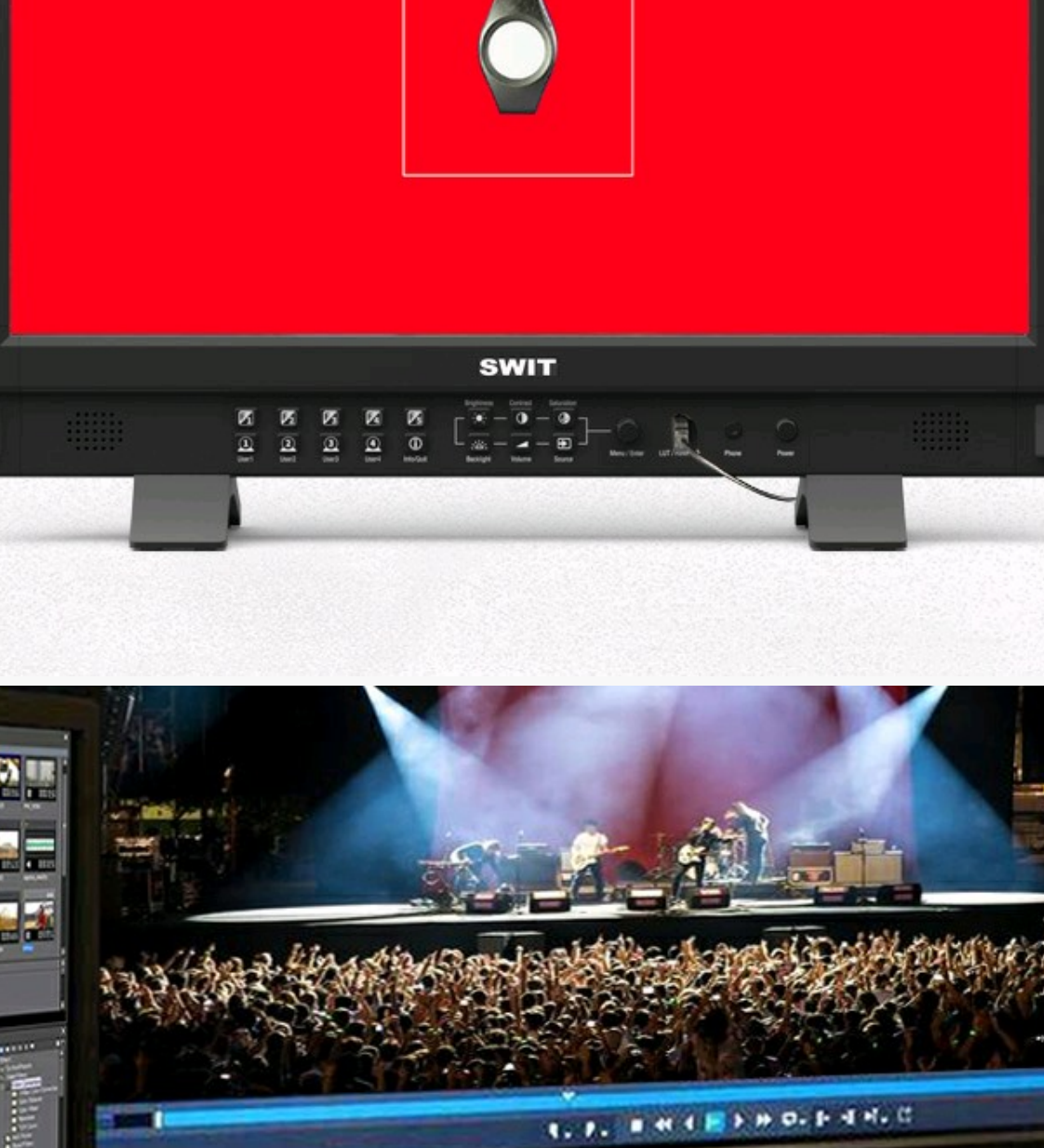

## Audio/Video Zero Latency

Support Zero latency mode (less than 1/100 Frame) for lip-sync monitoring.

## HDR/SDR De-log LUTs

The monitor has built-in multi camera logs to HLG1000, PQ1000, Rec 709 SDR conversion LUTs, including Log-C, C-log, S-log2, S-log3, V-log, J-log1, RedLogFilm etc. You can also upload User LUTs to monitor by USB disk, support 17x17x17 3DLUT cube files.

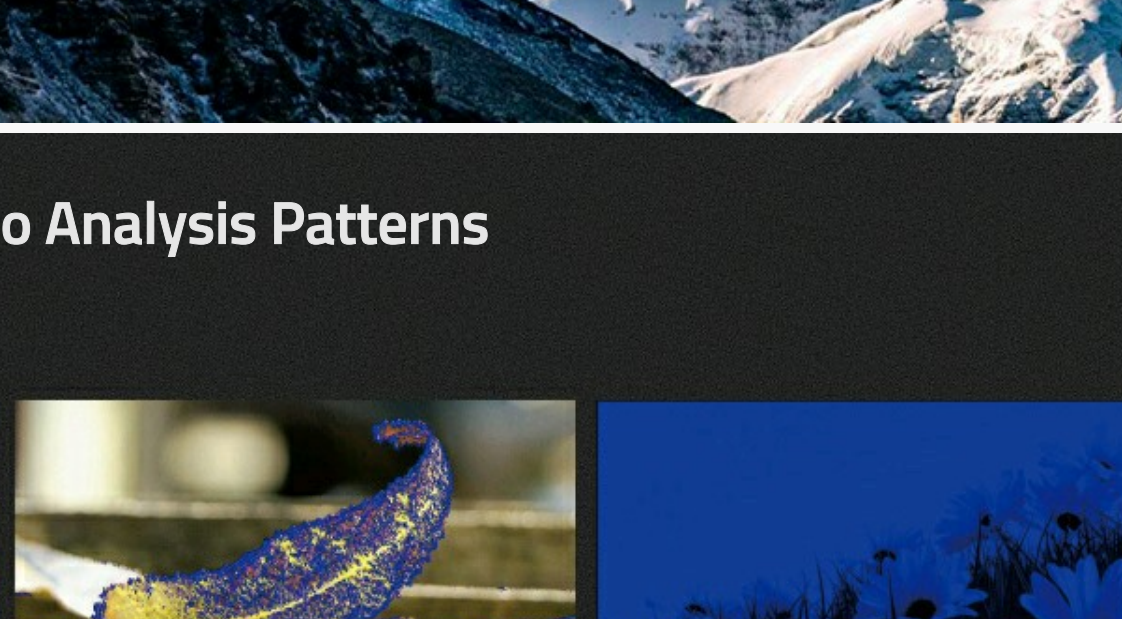

## Multiple Video Analysis Patterns

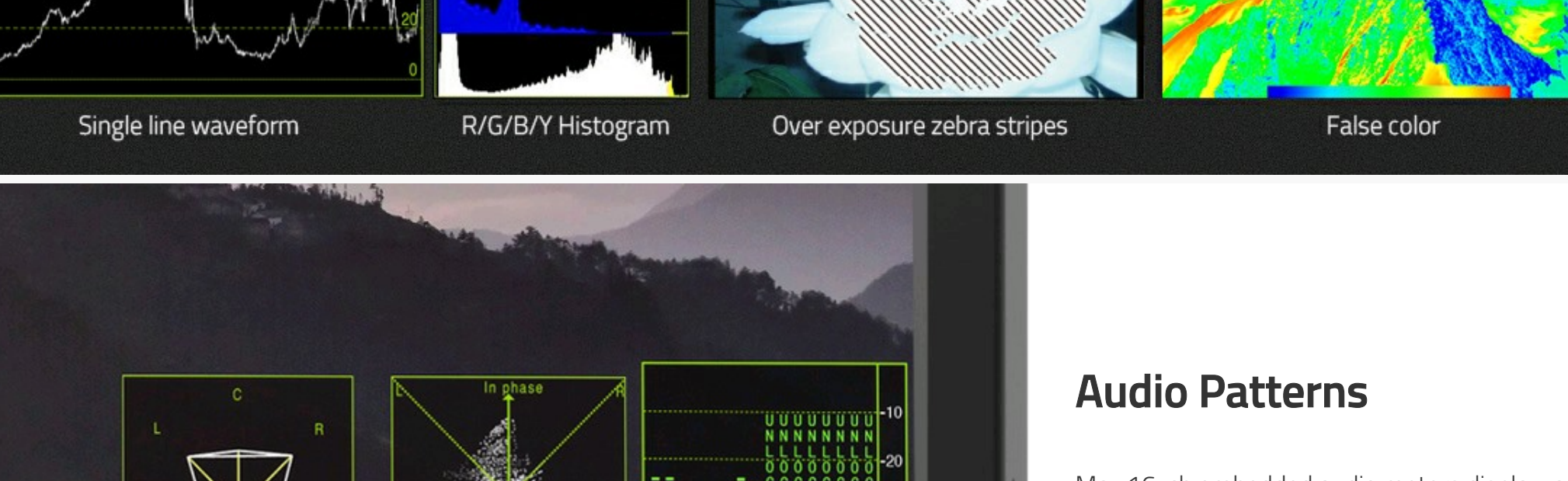

## Audio Patterns

Max 16-ch embedded audio meters display, and select any 2 channels audio to output via speaker or 3.5mm headphone socket. Moreover, BM-H monitors support Lissajous figures and 5.1 & 7.1 surround sound patterns.

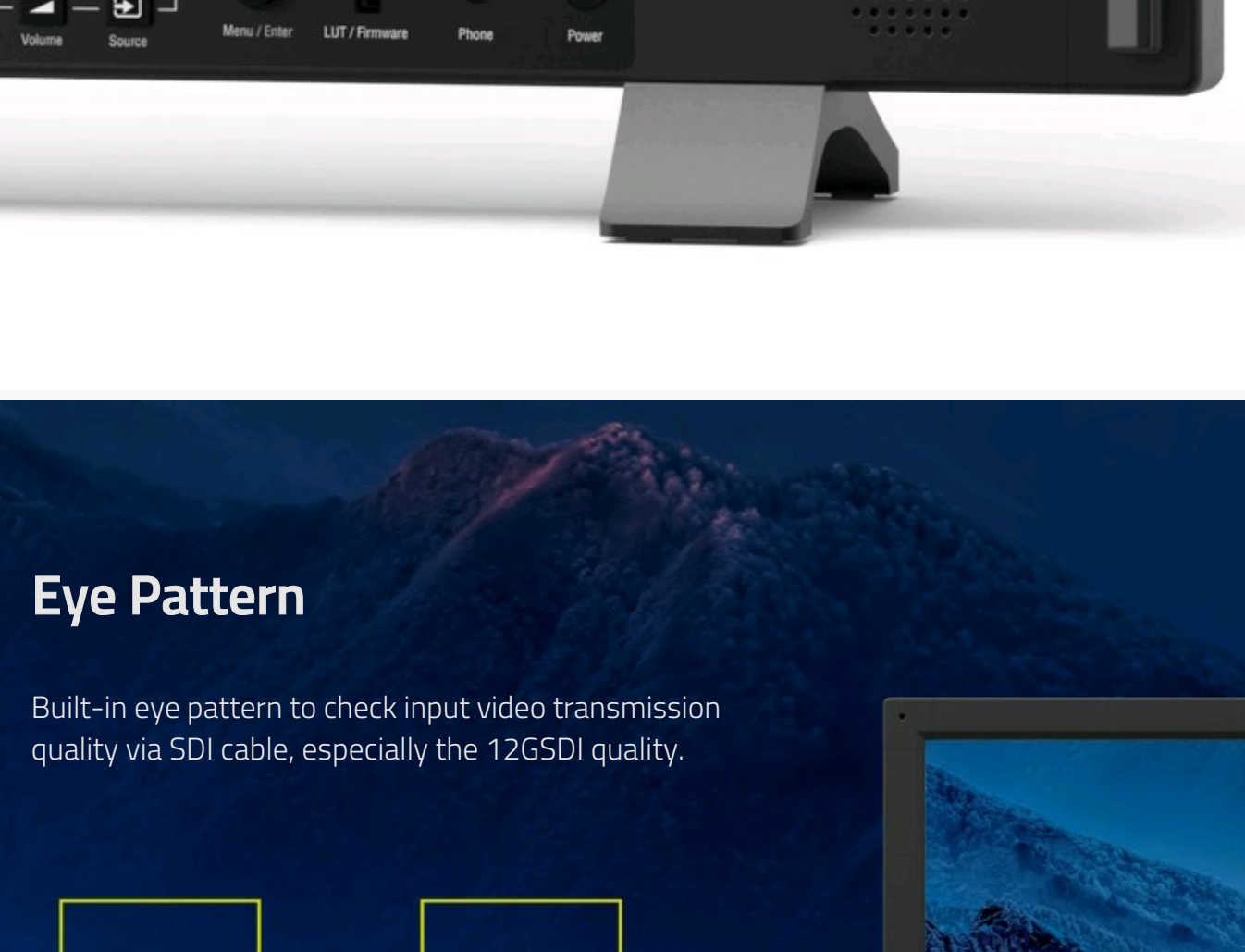

## Eye Pattern

Built-in eye pattern to check input video transmission quality via SDI cable, especially the 12GSDI quality.

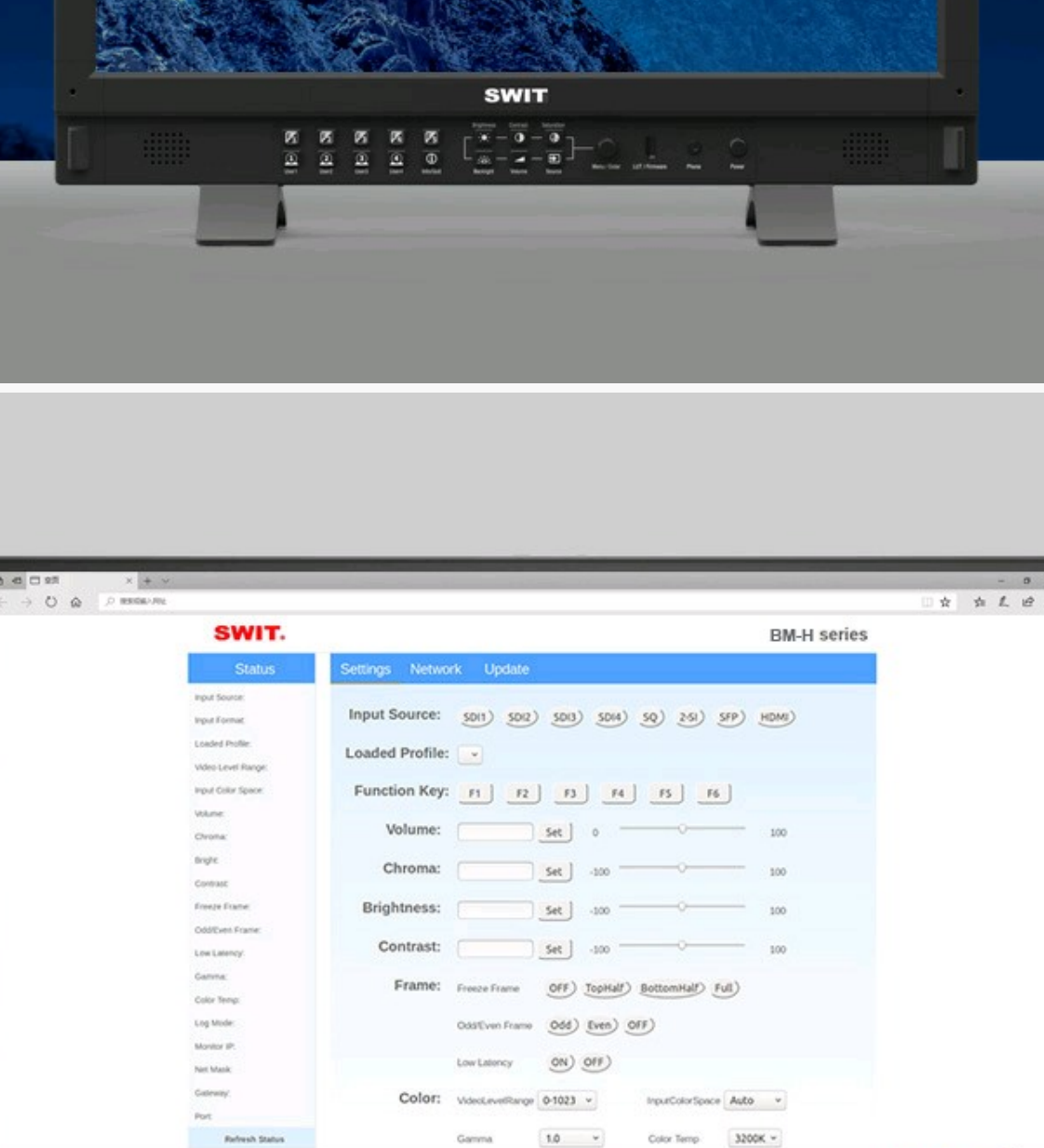
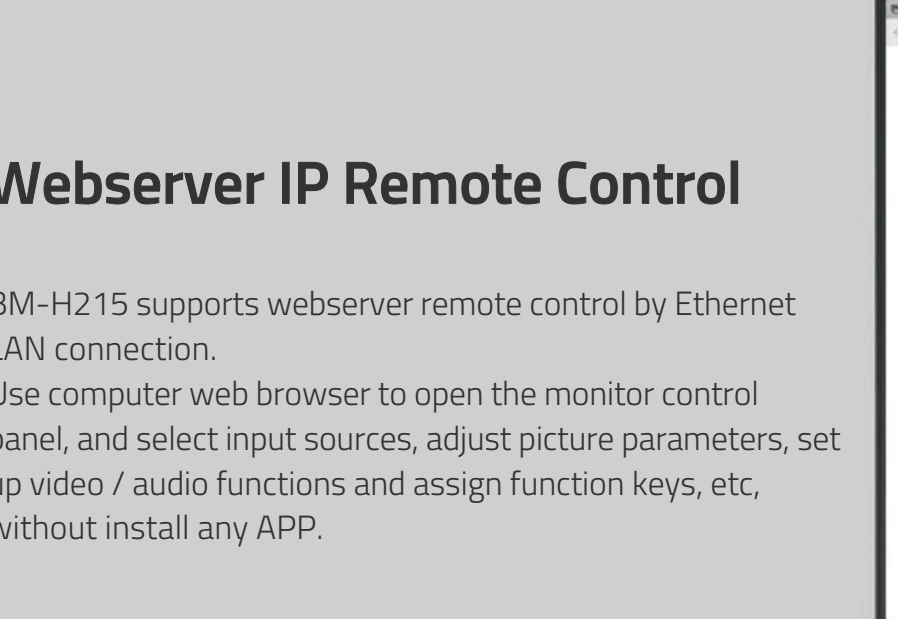

## Webserver IP Remote Control

BM-H215 supports webserver remote control by Ethernet LAN connection. Use computer web browser to open the monitor control panel, and select input sources, adjust picture parameters, set up video / audio functions and assign function keys, etc, without install any APP.



## Power Supply

BM-H215 consumes 60W power, supports both AC 100-240V input and 4-pin XLR DC 12-17V input, and equipped with a V-mount battery plate on the rear panel. (Gold mount for option)





## All 4K Inputs **BM-H215** 100% P3 WCG QLED HD Broadcast Monitor

**12G-SDI** **4x 3G** **HDMI 2.0** **Quadview**

### Features

#### ■ 21.5-inch FHD Wide Color Gamut QLED Panel

1920x1080 IPS FHD QLED panel, 100% DCI-P3 coverage Wide Color Gamut, 400nits backlight, 1000:1 contrast, H/V 178° viewing angle for professional productions.

#### ■ All 4K Inputs, Future-proof

Support 12GSDI, Quadlink 4x3GSDI and HDMI2.0 multiple 4K inputs, and pixel-to-pixel zoom-in on the HD panel.

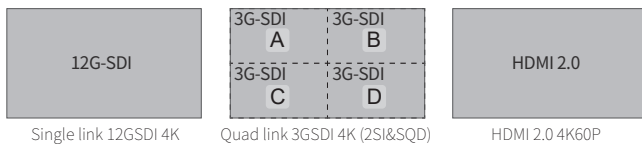

#### ■ Quadview and PBP/PIP view

Support 4x SDI/HDMI mixed multiview and display waveform, vector, audio meters, EOTF, color gamut, UMD for each input. Support 2 inputs PBP or PIP display.

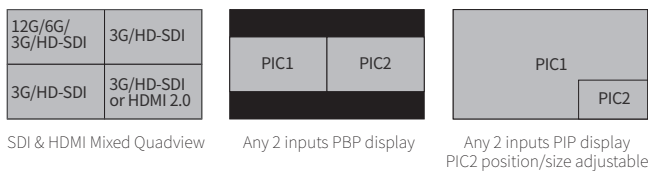

#### ■ HDR/Color Gamut selection, Payload ID auto setting

Gamma 1.0/1.8/2.2/2.4/2.6 or HLG/PQ/Slog3 HDR selection; BT.709, DCI-P3, BT.2020 selection; Payload ID auto set input range, color space, HDR/SDR, color gamut, color depth, etc.

#### ■ Multi Color Gamut & EOTF Viewing

1 input source copied to 4 windows and display different HDR/SDR and color gamut simultaneously.

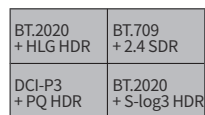

HDR/SDR simultaneously view

#### ■ 18-bit Processing / Zero Latency

Internal 18-bit signal processing, and less than 1/100 frames audio/video latency for lip-sync monitoring.

#### ■ Delog 3DLUTs & User 3DLUTs Upload

With built-in De-log LUTs including Log-C, S-log2, S-log3, C-log, V-log and RedLogFilm LUTs, to convert Log video to 709 SDR or HLG/PQ HDR. Support User 3DLUTs upload by USB.

#### ■ 3DLUT Auto Self-Calibration

Built-in calibration software, supports X-rite i1 and JETI Specbos 1211 probes directly plug into monitor USB port to auto calibrate. Calibration time: X-rite i1: 15min; Specbos1211: 45min  
Calibration result:  $\Delta E < 1.0$

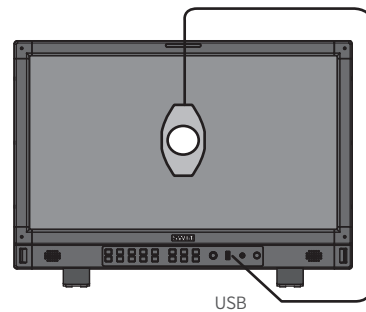

Built-in 3DLUT calibration software, Directly connect color sensor probe to monitor USB port, and the monitor will calibrate itself automatically.

#### ■ Video Assist Patterns, 12GSDI Eye Pattern

Waveform and single line selection, Vector scope, Histogram and unique Color Gamut pattern and Eye pattern for 12GSDI, supports multiple display position, size and color selection for the patterns.

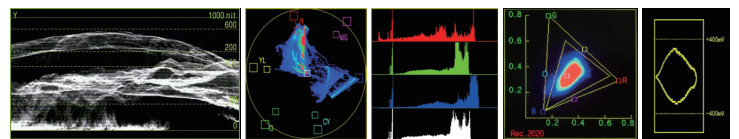

Y/Cb/Cr/R/G/B Waveform with nits Support single line waveform Vector Scope R/G/B/Y Histogram Rec. 709/2020 Color Gamut Pattern Eye Pattern

#### ■ Audio Assist Patterns

16-ch audio meters, and select any 2-ch to output via 3.5mm or speakers; Support Lissajous and 5.1/7.1 surround patterns.

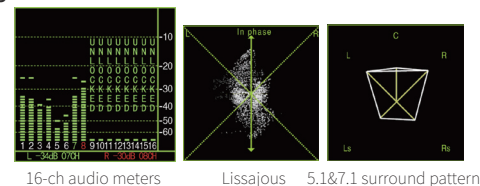

#### ■ Others

Focus assist, R/G/B/mono, False color, Zebra, H/V delay, Freeze; 15:9, 14:9, 13:9, 4:3, 2.35:1, 2:1, 1.85:1 and User defined markers; Support TSL 3.1/4.0 UMD and text TALLY display; GPI control and webserver IP control, USB firmware updates.

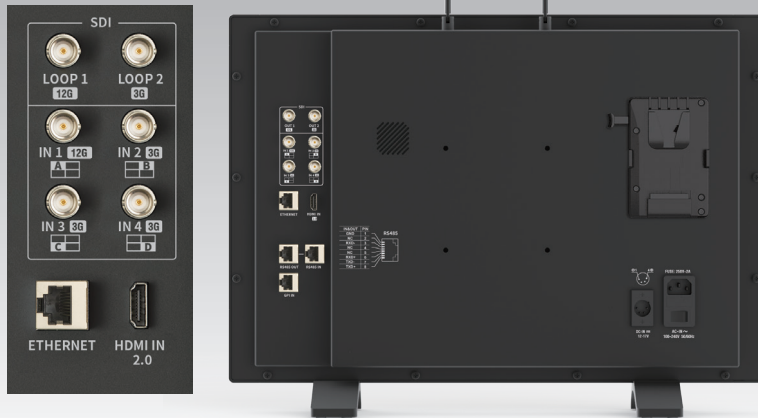

- ◆ 100% DCI-P3 WCG QLED Panel
- ◆ 4K Inputs: 12GSDI / 4x3G / HDMI 2.0
- ◆ Multi CG/EOTF Simultaneous View
- ◆ Eye Pattern, Surround Sound pattern
- ◆ 3DLUT Self-calibration,  $\Delta E < 1.0$

## Video Formats

### SDI IN1 & LOOP1 (12G)

4096×2160p (60 / 59.94 / 50 / 30 / 29.97 / 25 / 24 / 23.98)  
 3840×2160p (60 / 59.94 / 50 / 30 / 29.97 / 25 / 24 / 23.98)  
 2048×1080p (60 / 59.94 / 50 / 30 / 29.97 / 25 / 24 / 23.98)  
 2048×1080i (50 / 59.94 / 60)  
 1080p (60 / 59.94 / 50 / 30 / 29.97 / 25 / 24 / 23.98)  
 1080i (60 / 59.94 / 50)  
 1080psf (30 / 29.97 / 25 / 24 / 23.98)  
 720p (60 / 59.94 / 50)  
 480i (59.94) 576i (50)

### SDI IN2/3/4 & LOOP2 (3G)

2048×1080p (60 / 59.94 / 50 / 30 / 29.97 / 25 / 24 / 23.98)  
 2048×1080i (50 / 59.94 / 60)  
 1080p (60 / 59.94 / 50 / 30 / 29.97 / 25 / 24 / 23.98)  
 1080i (60 / 59.94 / 50)  
 1080psf (30 / 29.97 / 25 / 24 / 23.98)  
 720p (60 / 59.94 / 50)  
 480i (59.94) 576i (50)

### 4K Quad-link SDI IN (each channel)

2048×1080p (60 / 59.94 / 50 / 30 / 29.97 / 25 / 24 / 23.98)  
 1080p (60 / 59.94 / 50 / 30 / 29.97 / 25 / 24 / 23.98)

### HDMI IN (2.0)

4096×2160p (60 / 59.94 / 50 / 30 / 29.97 / 25 / 24 / 23.98)  
 3840×2160p (60 / 59.94 / 50 / 30 / 29.97 / 25 / 24 / 23.98)  
 1080p (60 / 59.94 / 50 / 30 / 29.97 / 25 / 24 / 23.98)  
 1080i (60 / 59.94 / 50)  
 720p (60 / 59.94 / 50)

## Specifications

| Model   |                       | BM-H215                    |
|---------|-----------------------|----------------------------|
| Display | Size                  | 21.5 inches                |
|         | Panel Type            | QLED                       |
|         | Resolution            | 1920×1080                  |
|         | Aspect Ratio          | 16:9                       |
|         | Color Depth           | 10bit (8+2FRC)             |
|         | Internal Processing   | 18bit                      |
|         | Viewing angle         | H/V 178/178                |
|         | Brightness & Contrast | 400nits, 1000:1            |
| Input   | SDI 1                 | 12G/6G/3G/HD-SDI ×1        |
|         | SDI 2/3/4             | 3G/HD-SDI ×3               |
|         | HDMI                  | HDMI 2.0 ×1                |
|         | UMD                   | RS485×1                    |
|         | GPI (Tally)           | RS485×1                    |
|         | Ethernet              | RJ45×1, 1000M              |
|         | USB                   | USB-A×1 – 3DLUT & Firmware |
| Output  | SDI 1                 | 12G/6G/3G/HD-SDI Loop ×1   |
|         | SDI 2                 | 3G/HD-SDI loop ×1          |
|         | Analog audio          | 3.5mm headphone + Speaker  |
|         | UMD                   | RS485×1                    |
| General | AC Input              | AC 100-240V 50/60Hz        |
|         | DC Input              | DC 12-17V, V-mount plate   |
|         | Power                 | ≤60W                       |
|         | Working environment   | 0°C - +40°C; 10% - 90%     |
|         | Storage environment   | - 15°C - + 60°C; 10% - 90% |
|         | Dimensions            | 530.6×364.3×74.2mm         |
|         | Weight                | 6.05kg                     |

