



The 520DD-AESU is a professional Dolby audio decoder that automatically detects Dolby-E®, Dolby Digital (AC-3)™, and PCM streams in the AES input, and translates them to PCM (linear) audio. Up to 8 discrete audio channels may be contained in 1 AES stream when encoded as Dolby-E®, yielding up to 4 AES PCM outputs. A fifth stereo pair is obtained as the downmix of the above multi-channel audio. It can be mono, stereo or surround (ProLogic) and may optionally be routed to the output.

So that the multi-channel outputs in PCM form can be re-assembled back into Dolby-E® or Dolby Digital further downstream, an additional output with metadata is provided. It contains information about the assumed inter-channel relationships (whether they are 5.1, or 4 stereo pairs, etc.), their expected dialogue levels, etc.

Dolby-E® is capable of carrying LTC data embedded within its stream. It can be selected as an output, instead of metadata.

For lipsync cohesion and ease of editing, Dolby-E® data is organized in blocks with lengths matching associated video frame. The decoder will match the beginning of each output block with the start of video, as provided with the genlock input. Additional delay can be dialed up by the user, up to 3 seconds. Reference video frame rate must match that assumed by the Dolby-E® stream. An extra AES input is provided that can be configured as a backup channel, in the event the primary is lost, or as a voice-over source.

The 520DD-AESU is housed in the 3RU 500FR **exponent** frame that will hold up to 16 modules.

► Features & Benefits

- Headphone jack with monitoring stereo down-mix
- Secondary AES input with backup contents or voice-over
- Card edge display for Dolby decoder status & audio channel peak levels bargraphs
- Adjustable audio delay up to 3 seconds, independent for all 8 channels
- VistaLINK® -capable for remote monitoring via SNMP (using VistaLINK® PRO) when installed in 500FR frame with 500FC VistaLINK® Frame Controller

Inputs

- 1 Unbalanced AES (SMPTE 276M standard version on coax) with Dolby-E®, Dolby Digital or PCM (autodetect)
- 1 Unbalanced AES (SMPTE 276M standard version on coax) with voice over PCM
- Video genlock - composite black or tri-level (autodetects) for lip-sync management, Dolby-E® style

Outputs

- 2 outputs with reshaped AES input
- 4 AES (SMPTE 276M) output with decoded PCM audio
- Metadata or LTC
- Available ProLogic downmix

Card Edge LEDs

- Module status
- AES input health
- Dolby decoder processing status
- Genlock health

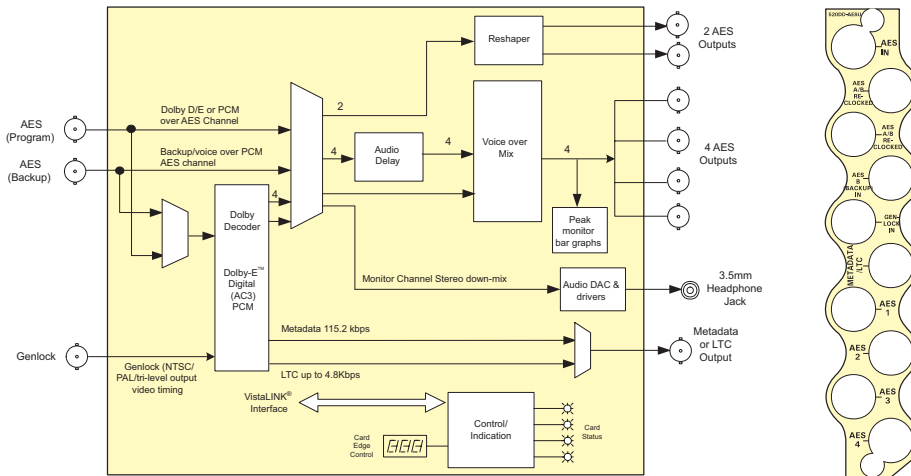

► Specifications

AES Audio Input:

Number of Inputs: 2 (program, backup)
 Standard: SMPTE 276M, unbalanced AES
 Connectors: BNC per IEC 61169-8 Annex A
 Signal Level: 0.1 to 2.5V p-p
 Equalization: Auto > 1000m with 1V p-p drive and Belden 1694A or equivalent coax cable
 Resolution: 24 bits
 Sample Rate: 48kHz; ±100ppm
 Input Impedance: 75Ω
 Return Loss: > 25dB, 100kHz to 6.0MHz

Connector: 1 BNC per IEC 61169-8 Annex A
 Impedance: Hi-Z or 75 jumper configurable
 Return Loss: > 40dB to 10MHz

Metadata Output:

Number of Outputs: 1
 Type: Dolby Metadata SMPTE RDD6
 Connector: BNC per IEC 61169-8 Annex A (shared with LTC output as per user selection)
 Signal Level: < ±3V @ 4kΩ load
 Output Impedance: 50Ω, DC coupled
 Rise Times: 200ns

Headphone Audio Outputs:

Number of Outputs: 1
 Type: Stereo 3.5mm jack
 Output Load: 32Ω
 Signal Level: 100mW max, soft adjustable over 40dB range
 THD+N: 1%
 SNR: 90dB RMS, "A" weighted

Electrical:

Voltage: +12V DC
 Power: 6W
 EMI/RFI: Complies with FCC Part 15 Class A EU EMC Directive

AES Audio Outputs:

Number of Outputs: 6 (2 relocked & 4 PCM decodes)
 Standard: SMPTE 276M, unbalanced AES
 Connectors: BNC per IEC 61169-8 Annex A
 Sample Rate: 48kHz
 Impedance: 75Ω unbalanced
 Return Loss: > 25dB, 100kHz to 6.0MHz

LTC Output:

Number of Outputs: 1
 Standard: SMPTE 12M-1
 Connector: BNC per IEC 61169-8 Annex A
 Signal Level: Adjustable from 0.5 to 4.0V p-p @ 1kΩ load
 Output Impedance: 50Ω
 Rise Times: 40μs ±10μs

Physical:

Number of slots: 1

► Ordering Information

520DD-AESU Dolby-E/AC-3™ Decoder

Enclosures
 500FR
 S501FR

exponent
 Compact High Density Distribution Frame
 Standalone enclosure