



ECARTONIE

professional camera support

product line ■

Every part of a **CARTONI** support system originates from technical research that aims for performance perfection:

The **FLUID DRAG SYSTEM**, with several patents such as the modular labyrinth combination, the variable labyrinth and the planetary fluid control incorporated in the various Fluid Heads. **CARTONI** camera support heads assure smooth, precise and repeatable movements to a camera.



The **COUNTERBALANCE**, with the modular helical spring system, the patented silicon padded variable system or the patented steel cable system allows the perfect counterbalance of the camera throughout the tilt mode. The camera correct centering is possible thanks to the accurate sliding plates hosting the quick release camera attachment.



The **EASY READABLE SETTINGS**, all conveniently placed and assisted by digital readout, and the illuminated spirit level, ensure fast and precise set up.

The **STURDY TRIPODS**, manufactured in special alloys or carbon fiber composites, guarantee absolute stability and virtually no torque effect with their self-adjusting leg coupling and precise and positive height locks.



The **PORTABLE, LIGHTWEIGHT** and **VERSATILE PEDESTALS** with the innovative design in the pneumatic column allow for torque-free elevation movement.

The **EXTREMELY STABLE WHEEL UNITS** mounted on 6 high precision bearings.

Constant research and the direct input from the end-user are the secrets of our success.

omega	2
sigma	3
master	4
C40S - C60S	5
C20S	6
dutch head	7
lambda & 3 rd axis	8
spinhead	9
smarthead	10
mo-sys lambda	11
e-rem	12
e-sensor	13
e-focus	14
delta	15
gamma	16
laser	17
focus	18
hidv	19
status pro	20
P90 pedestal	21
P50 - P70 pedestal	22
P20 pedestal	23
jib	24
tripods studio & ob	25
tripods efp	26
tripods dv & eng	27
accessories	29

Designed to support the latest **STUDIO** and **OB** cameras, the **OMEGA** is an extremely compact Fluid Head incorporating a highly precise patented counterbalance system as well as an advanced fluid damping module in both pan and tilt modes.

The **OMEGA** counterbalance mechanism is ideal for camera configurations with a high center of gravity up to 80 kg (176 lbs) giving a perfect response throughout the tilt range. All settings are connected with a digital read out. The camera is fixed on a V-shaped wedge plate according to international standards and the precise centering of the c/g is achieved by a fine tuning crank placed underneath the rear section of the sliding plate.

The **OMEGA** interfaces directly with any flat Mitchell base or 150mm bowl base and can be mounted on top of all existing pedestals featuring the 4-hole bores.

The Fluid Head weighs only 15 kg (33 lbs) and comes equipped with an integrated soft grip carrying handle, two telescopic pan bars, and illuminated spirit level.

■ specifications

Payload capacity:	80 Kg (176 lbs)
Weight:	15 Kg (33 lbs)
Pan range:	360°
Tilt range:	+/- 65°
Counterbalance:	Continuous
Fluid drag:	Continuous
Bowl diameter:	Flat Mitchell/150mm
Temp. range:	-40°/+60°C (-40°/+158°F)

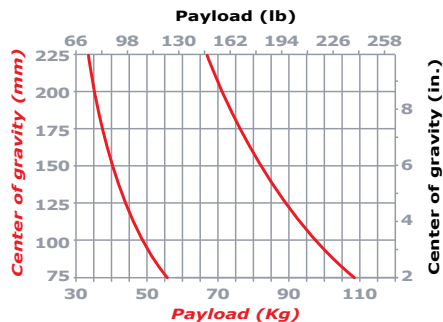

accessories ■

A 935



A 865



A 951





Designed to support cameras weighing from 10 Kg (22 lbs) to 40 Kg (88 lbs) the **CARTONI SIGMA** combines a wide range of counterbalance capabilities with an outstanding fluid damping system.

The frictionless variable fluid modules perform a wide variety of fluid drag allowing smooth and precise movements in any shooting situation.

The new patented counterbalance system supports a wide range of payloads at any angle throughout the +/- 90° tilt angle.

All operating knobs and levers are conveniently located and easy to reach with a special care for ergonomics.

The head comes equipped with two telescopic pan bars, illuminated spirit level and digital readouts for drag and counterbalance settings.

In the **35/16MM** Film version the head is supplied with one telescopic pan bar, one front small pan handle and the eye piece extension holder.

■ specifications

Payload capacity:	40 Kg (88 lbs)
Weight:	12 Kg (26 lbs)
Pan range:	360°
Tilt range:	+/- 90°
Counterbalance:	Continuous
Fluid drag:	Continuous
Bowl diameter:	Flat Mitchell/150mm
Temp. range:	-40°/+60°C (-40°/+158°F)



accessories ■

A 930



A 903



A 895

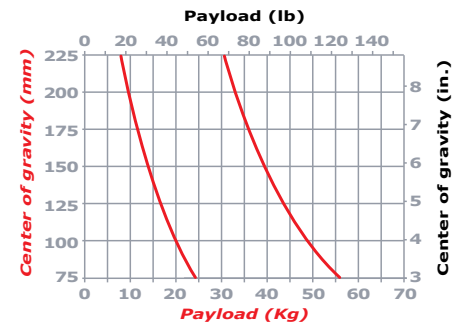

Designed to support cameras weighing from 10 Kg (22 lbs) to 30 Kg (66 lbs) the **CARTONI MASTER** combines a wide range of counterbalance capabilities with an outstanding fluid damping system.

The frictionless variable fluid modules perform a wide variety of fluid drag allowing smooth and precise movements in any shooting situation.

The new patented counterbalance system supports a wide range of payloads at any angle throughout the +/- 90° tilt angle.

All operating knobs and levers are conveniently located and easy to reach with a special care for ergonomics.

The head comes equipped with two telescopic pan bars, illuminated spirit level and digital readouts for drag and counterbalance settings.

■ specifications

Payload capacity: **30 Kg (66 lbs)**

Weight: **6,5 Kg (14 lbs)**

Pan range: **360°**

Tilt range: **+/- 90°**

Counterbalance: **Continuous**

Fluid drag: **Continuous**

Bowl diameter: **Flat Mitchell/150mm**

Temp. range: **-40°/+60°C (-40°/+158°F)**

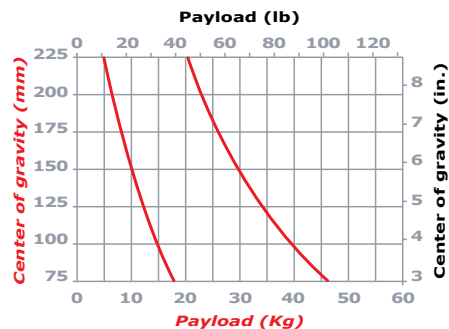

accessories ■

A 933



A 849/M



T 625/R





The **C40S** is a heavy duty Fluid Action Head specifically designed to support **FILM** and **STUDIO** cameras weighing up to 45 kg (99 lbs).

Counterbalance mechanism is activated by an 8-position easy grip selector, while the fluid control system allows the damping levels to range from "0" for free wheeling to 7 for maximum drag on both pan and tilt modes.

Standard features include the quick-release camera plate with safety lock, two adaptable telescopic pan bars and illuminated spirit level. The head comes equipped with a flat Mitchell base, and options include a **150MM** bowl base and the eye piece extension holder.

For **STUDIO/OB** configurations weighing up to 55 Kg (121 lbs), **C60S** offers an extremely cost-effective option. **C40S** and **C60S** interface directly with the Studio tripod series or the Heavy Duty tripods for extra ruggedness.

■ specifications

Payload capacity: **45 Kg (99 lbs)**

Payload capacity C60S: **55 Kg (121 lbs)**

Weight: **11 Kg (24 lbs)**

Pan range: **360°**

Tilt range: **+/- 65°**

Counterbalance: **7 steps + 0**

Counterbalance C60S: **4 steps + 0**

Fluid drag: **7 + 7**

Bowl diameter: **Flat Mitchell/150mm**

Temp. range: **-40°/+60°C (-40°/+158°F)**



accessories ■

A 849



A 850/C 4



A 891

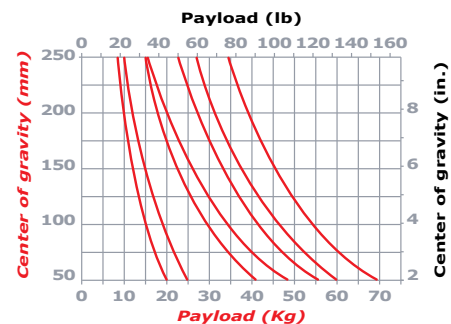

Designed to provide an extremely stable support for standard **EFP** configurations, the **C20S** is ready to operate with a wide range of cameras weighing from 7 to 25 Kg (15 to 55 lbs).

C20S features three award winning fluid damping modules assuring outstanding drag levels and extraordinary smoothness in both pan and tilt modes.

Movements can be selected with 7 precisely repeatable steps of drag, while free wheeling is available by simply setting the drag selector ring into position "0".

Counterbalance is activated by an easy grip selector in 7 progressive steps and "0".

The **C20S** comes with a 100mm bowl base, illuminated spirit level and two telescopic pan bars. A 150 mm bowl base is also available as an option.

■ specifications

Payload capacity: 25 Kg (55 lbs)

Weight: 6,5 Kg (14 lbs)

Pan range: 360°

Tilt range: +/- 65°

Counterbalance: 7 steps + 0

Fluid drag: 7 + 7

Bowl diameter: 100/150mm

Temp. range: -40°/+60°C (-40°/+158°F)

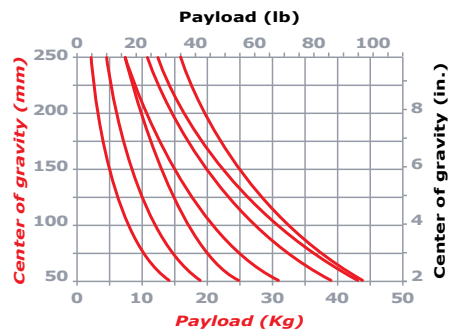

accessories ■

A 850/C 2



A 845



D 734





This special accessory has been conceived to add a 3rd axis to a standard Fluid Head and allow the lateral movement called "Dutch angle", enhancing special effects.

Available in **C20S** and **C40S** size the **CARTONI DUTCH HEAD** is designed to make exceptionally smooth side-tilt effects simple and straightforward to execute.

The **DUTCH HEADS** integrate the award-winning **CARTONI** fluid module in progression from "0" to 7 intensity. The counterbalance system features the 7 step spring mechanism.

In both versions **CARTONI DUTCH HEADS** interface directly with the quick release plate on the top of the main Fluid Head, and with the same size camera plate to attach the camera assembly.

A special telescopic pan bar completes the equipment.

■ specifications

C20S Dutch Head:

Payload capacity:	25 Kg (55lbs)
Weight:	5 Kg (11 lbs)
Tilt range:	+/- 65°
Counterbalance:	7 steps + 0
Fluid drag:	7settings + 0
Base:	120x80x7mm plate
Temp. range:	-40°/+60°C (-40°/+158°F)

C40S Dutch Head:

Payload capacity:	45 Kg (100 lbs)
Weight:	8 Kg (17 lbs)
Tilt range:	+/- 65°
Counterbalance:	7 steps + 0
Fluid drag:	7settings + 0
Base:	120x80x7mm plate
Temp. range:	-40°/+60°C (-40°/+158°F)



accessories ■

C 911



The **LAMBDA** is a "NODAL SWING HEAD" ideally suited for **35MM** film cameras fully equipped with long lenses, mattebox and extra large film magazines.

Providing a high level of operational flexibility, this Fluid Head can be easily fitted to a wide range of supports including tripods, dollies, cranes and camera cars. The mounting can be inverted in under-slung position for low line positioning and allow the camera to be moved all the way to the ground and provide for accurate images which normally cannot be obtained with other traditional supports.

The balance system is designed so that the camera may swing on its center of gravity and **ROTATE 360°** on its vertical axis. No springs or similar counter reaction elements are required to set the head in a fixed tilt position and fluid pan and tilt movements have the same identical feel. The lens focal distance can be kept constant by presetting the fore and aft horizontal sliding plate.

The **LAMBDA** employs the patented **CARTONI** fluid drag control system on both pan and tilt modes. In order to obtain the **3RD AXIS** rotation, the **LAMBDA** features the 3rd Axis accessory comprising an additional fluid drag system with 7 steps + "0".

A variety of accessories as the orientable extendable pan bar, the round steering wheel, the short pan handle, the 150mm bowl base, the counterweights and rods for nodal setting complete the equipment.



■ specifications

Payload capacity: **40 Kg (88 lbs)**

Weight: **21 Kg (46 lbs)**

3rd Axis weight: **15,5 Kg (35 lbs)**

Pan range: **360°**

Tilt range: **360°**

3rd Axis range: **360°**

Fluid drag: **7+7**

Bowl diameter: **Flat Mitchell/150mm**

Temp. range: **-40°/+60°C (-40°/+158°F)**



3rd axis



accessories ■

A 833/L



A 890



A 850/L



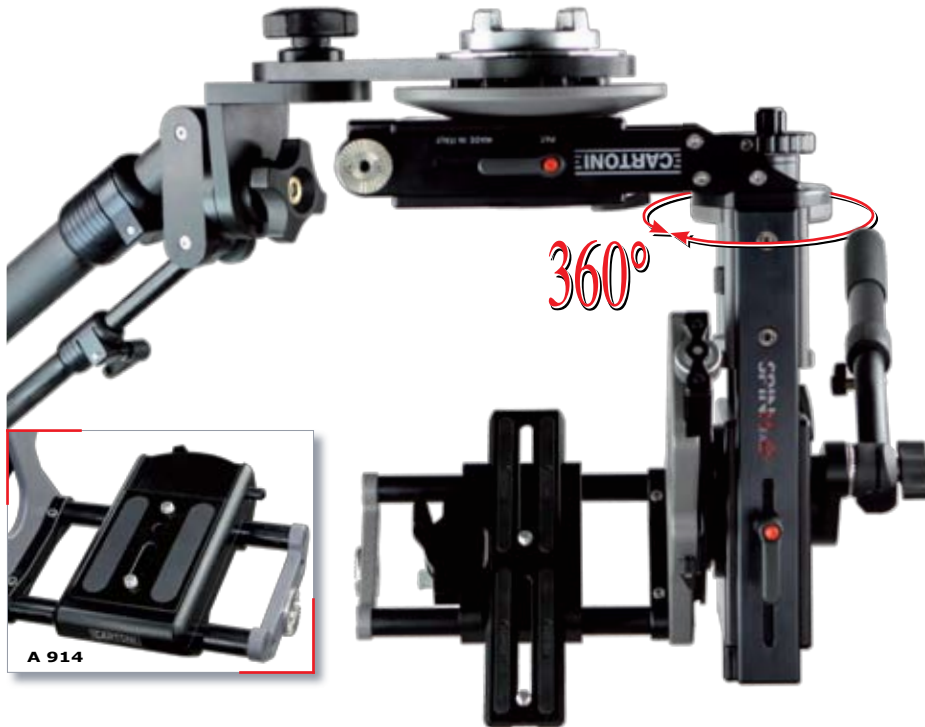

A 914

This new **CARTONI SPINHEAD** is an innovative and unique support Head for any film or video camera weighing up to 15 kg (33lbs).

Its **"L"** shape configuration allows to operate at **NODAL SETTING** (coincidence of the rotation center with the optical center) on a tripod, on a dolly, on camera cars, underslung from a crane or jib arm.

Both pan and tilt movements are assisted by **CARTONI** patented continuous fluid drag units.

These fluid drag modules are hollow in the center in order to allow cables and plugs. The unique and patented feature is a spinning tilt unit which offsets the camera allowing to pivot the camera plate for **360°** degrees and lock it at any angle you may desire.

All settings are easily accessible and comfortable to operate, the camera can be centered on board with micrometric cranks. The camera attachment is achieved by a quick release long dovetail plate or alternatively with a cinestyle european quick release camera plate.

■ specifications

Load capacity:	15 kg (33 lbs)
Weight:	10kg (22 lbs)
Pan range:	360°
Tilt range:	360°
Spin range:	360°
Temp. range:	-40°/+60°C (-40°/+158°F)
Fluid drag:	continuous
Base:	flat Mitchell standard, compatible with Vinten 4 holes, 150mm



A 918



As the junior member of the **CARTONI "L"** shaped Heads, **SMARHEAD** offers an outstanding new tool to videographers.

SMARHEAD is a highly Professional **NODAL HEAD**, including precision cranks to perfectly balance the camera weight.

It features 3 drag settings in both pan and tilt mode as well as the zero drag for freewheeling, a quick release sliding camera plate, positive locks and 2 level bubbles.

SMARHEAD comes equipped with an extendable main pan bar, a short front panbar, counterweights for balance on the main pan bar. Counterweights for Nodal Setting available as an option.

The **SMARHEAD** can be used on a tripod as any fluid head, but also underslung, hanging from a jib arm or a crane for table-top shooting.

■ specifications

Load capacity:	5 kg (11 lbs)
Weight:	6 kg (13 lbs)
Pan range:	360°
Tilt range:	360°
Temp. range:	-40°/+60°C (-40°/+158°F)
Fluid drag:	3 + 0
Base:	100mm bowl



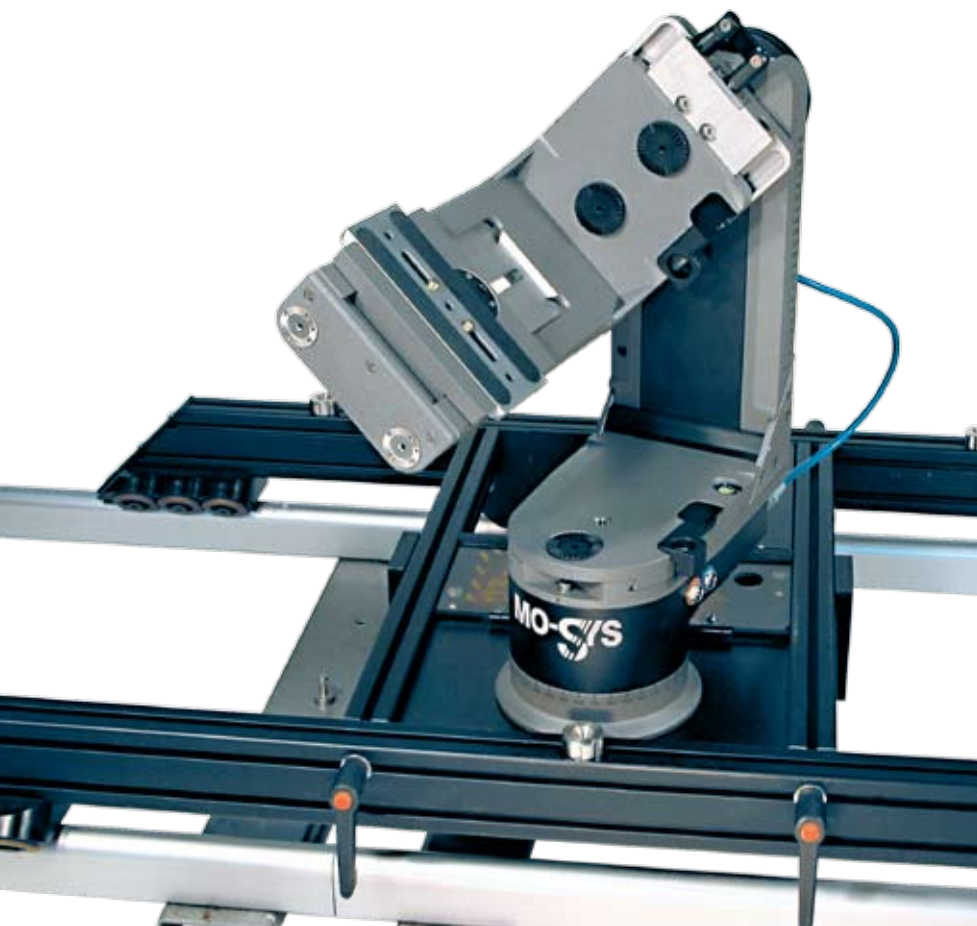

The **MO-SYS LAMBDA** motion control camera support head shares all the advantages and versatility of the regular **CARTONI LAMBDA** head. It features un-compromised, zero-backlash drive mechanics for precision, power and low maintenance.

Built in cooperation with **MO-SYS** (Motion Systems Technology Ltd) this state of the art equipment can be used for many different operations and configurations.

The head can be mounted on a variety of supports as tripod, cranes or dollies and the system can be completed with the 3-axis Lens Control Module, which is compatible with most digital lens motors.

With its embedded processors and a specific menu driven software, there is no need to lug around an external PC.

Programming is extremely simple and can be learned in one hour, and moves can be recorded live, in real time, using hand wheels, pan bar, joystick, or using key-frames.

The exact motion is stored in internal, non-volatile memory. It can be replayed again and again, at any speed, re-recorded, exported to post-production or modified. Another grip-friendly method is "manual mode", where physical maneuvering of the axes is recorded for future playback.

■ specifications

Head weight:	30 Kg (66 lbs)
Capacity:	30 Kg (66 lbs)
Max Pan Speed:	180 deg/sec
Power requirement:	15-30V DC

Playback speed settable from 0,03% to 600% of original recorded speed.

Input devices settings for Hand wheels, Force-sensitive pan bar, Remote pan bar, Joystick, Key frame.

Move back up and export with easy to use, Windows based PC software with USB interface.

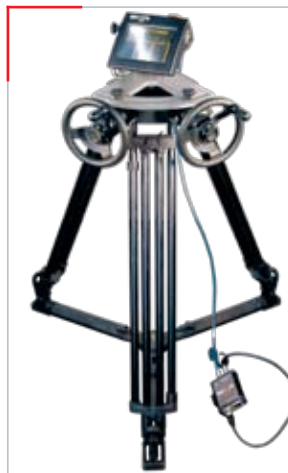

accessories ■

T 624



C 920



This new **CARTONI REMOTE CONTROL HEAD** engineered in partnership with UK's **MO-SYS LTD** - is for cameras and camcorders up to 15kg (33 lbs). Slipping-free, innovative cable routing and sleek design together with an affordable price makes the **e-REM 15** a highly competitive product.

Manufactured with sophisticated engineering precision the **e-REM 15** has multiple uses:

- Remote controlled head on top of cranes
- Virtual studios with position data output
- Multiple camera control for broadcasting

e-REM 15 can be operated with a joystick, slaveheads as the **CARTONI e-FOCUS** & **e-SENSOR**, handwheel set. A variety of shotbox options enable the different configurations



e-FOCUS

■ specifications

Payload capacity:	15 kg (33 lbs)
Weight:	8 kg (17,5 lbs)
Pan range:	360°
Tilt range:	360°
Base:	Flat



accessories ■

A 928



Console





accessories ■

T 623



C 915



The latest response to encoded support as needed in the **VIRTUAL REALITY** shooting.

Strong, versatile, including all features of a standard **CARTONI** fluid action camera support head, the **e-SENSOR** features extremely high resolution direct sensing encoders in both pan and tilt, absolute positioning with no need to recalibrate at start up, built-in electronic, simple cabling; a single cable supplies both power and data, with a range of up to 100m.

CARTONI e-SENSOR is powered by **MO-SYS** (Motion Systems Technology Ltd) and is compatible with most 3D packages for real time camera/scene movement in virtual set and pre-visualization, it is the ideal solution for sports 3D graphic insertions plus it is compatible with all **MO-SYS** control systems as an input device.

Connectors for lens encoders and other position sensors information are also possible to integrate to the **e-SENSOR** electronics, making it a very versatile contender on the virtual set.

■ specifications

Payload capacity:	30 Kg (66 lbs)
Weight:	6,5 Kg (14 lbs)
Pan range:	360°
Tilt range:	+/- 90°
Counterbalance:	7 steps +0
Fluid drag:	Continuous
Bowl diameter:	100mm
Pan resolution:	> 1 million counts/rev
Tilt resolution:	> 1 million counts/rev
Positioning:	absolute
Encoding transmission:	Direct - no gears. Single cable for power and position data

Created in response to the need for a small self-contained Fluid Head with built-in tracking encoders, the **e-FOCUS** is a compact yet extremely precise and performant camera support ideal in **VIRTUAL REALITY** shooting and position tracking.

THE CARTONI e-FOCUS features high resolution encoders for direct sensing in both pan and tilt, absolute positioning with no need to re-calibrate at start up, single cable for both power and data supply.

e-FOCUS is compatible with most **3D** softwares for real time camera/scene movements in virtual sets, previsualisation and 3D animation.

Extremely compact and light weight the **e-FOCUS** operates with continuously variable fluid damping modules in both pan and tilt movements and an unprecedented patented counterbalance system which covers all existing **DV** and **ENG** cameras.

■ specifications

Payload capacity:	1-10kg (2.3-22 lbs)
Weight:	3,5 kg (7.7 lbs)
Pan range:	360 °
Tilt range:	+/- 90 °
Counterbalance	continuous
Fluid drag:	continuous
Bowl diametre:	100mm
Tilt resolution:	> 1 million counts/rev
Pan resolution:	> 1 million counts/rev
Positioning:	absolute
Encoding transmission:	Direct, no gears. Single cable for Power and positioning data



accessories ■

D 734



T 627



C 928





Ideal for supporting **ENG** dockable camcorders or **EFP** cameras equipped with long focal lenses and top mounted viewfinders, the **DELTA** is manufactured with an extensive use of ultra-light magnesium alloy.

The fully variable counterbalance system is designed to accommodate offset payloads of 22 Kg (48 lbs) ensuring excellent performances at any tilt angle.

The **DELTA** features a continuously adjustable fluid damping mechanism providing extremely smooth and precise camera movements.

Standard performances of +70, -60 degrees, with the European style quick attachment camera plate, can be increased to +/- 90 ° with the optional sliding base plate.

Powered by a 9v battery, two digital displays indicate the counterbalance and tilt drag values, while an illuminated spirit level allows easy set-up even in low light conditions.

■ specifications

Payload capacity: **22 Kg (48 lbs)**

Weight: **3,5 Kg (7.7 lbs)**

Pan range: **360°**

Tilt range: **+/- 90° with sliding base plate
+70/-60 with quick attachment plate**

Counterbalance: **Continuous**

Fluid drag: **Continuous**

Bowl diameter: **100 mm**

Temp. range: **-40°/+60°C (-40°/+158°F)**

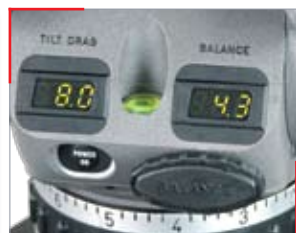

accessories ■

A 845



D 734



C 928

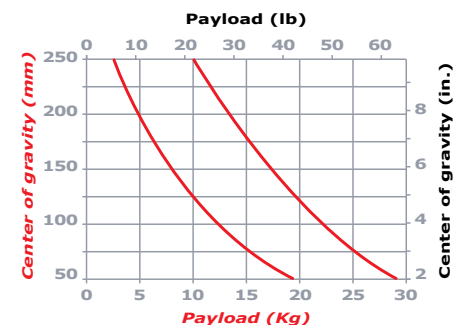

Safe and reliable, the **GAMMA** support is specifically designed for **ENG** configurations up to 16 Kg (35 lbs).

Featuring an infinitely variable counterbalance system with easy readable numerical reference, the **GAMMA** provides excellent performances at any angle from + 90 to -70 degrees. For additional tilt matching the -90° angle, an ultra light sliding plate is available.

A host of advanced features make this **FLUID HEAD** a bestseller in its range including infinitely adjustable drag settings, camera quick release system and illuminated spirit level.

The **GAMMA** head interfaces with a wide range of 100 mm bowl tripods both in aluminum or carbon fiber with either single or double stage extension.

■ specifications

Payload capacity: **16 Kg (35 lbs)**

Weight: **3,5 Kg (7.7 lbs)**

Pan range: **360°**

Tilt range: **+/- 90°**
with sliding base plate
+90° /-70°
with quick attachment plate

Counterbalance: **Continuous**

Fluid drag: **Continuous**

Bowl diameter: **100 mm**

Temp. range: **-40°/+60°C (-40°/+158°F)**

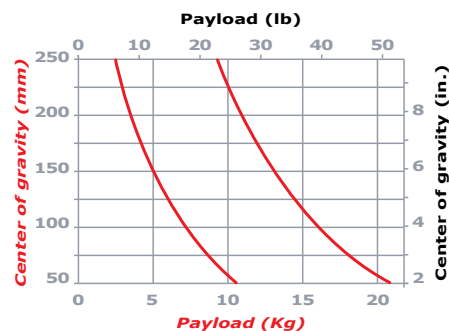

accessories ■

S 731/SML



D 734



C 928





Built of magnesium and aluminum alloy, the **LASER** is a very compact and lightweight Fluid Head designed for portable **DIGITAL CAMERAS** weighing up to 12 Kg (25 lbs).

Featuring an infinitely variable counterbalance, the **LASER** provides for excellent performances at any tilt position from +90 to -90 degrees.

The continuously variable fluid control system ensures consistent drag levels and smooth camera movements on both pan and tilt modes.

The **LASER** comes equipped with a 100 mm bowl base, telescopic pan bar and illuminated spirit level.

A wide range of **ENG** tripods are available both in aluminum or carbon fiber version with either single or double stage extension.

■ specifications

Payload capacity: **12 Kg (25 lbs)**

Weight: **3 Kg (7 lbs)**

Pan range: **360°**

Tilt range: **+/- 90°**

Counterbalance: **Continuous**

Fluid drag: **Continuous**

Bowl diameter: **100 mm**

Temp. range: **-40°/+60°C (-40°/+158°F)**

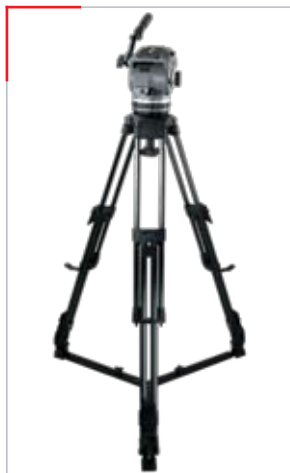

accessories ■

T 622



D 734



C 928

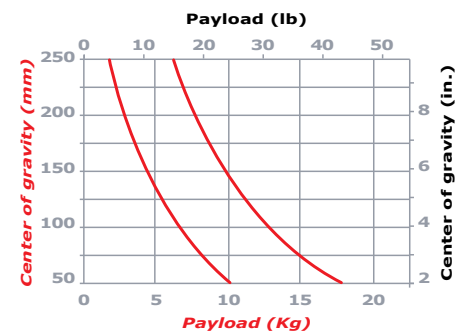

The **FOCUS** head is the ideal support for the latest **DV** cameras weighing from 0 to 10 Kg (0 to 22 lbs).

Extremely compact and lightweight, the innovative **FOCUS** features a continuously variable fluid damping system on both pan and tilt movements and a unprecedented patented variable counterbalance which brings its range of use to cover all existing **ENG** and **DV** cameras.

The **FOCUS** head comes equipped with a quick release sliding camera plate, illuminated spirit level and orientable pan bar. Its tilting angle is +/- 90° with perfect response throughout the entire tilt range.

It interfaces with all 100mm bowl base tripods and supports. The extreme ruggedness and versatility together with an outstanding quality/price ratio make the **FOCUS** the best possible support for **NEWS** operators and **DV** videographers.

■ specifications

Payload capacity: 0-10 Kg (0-22 lbs)

Weight: 2 Kg (4.4 lbs)

Pan range: 360°

Tilt range: +/- 90°

Counterbalance: Continuous

Fluid drag: Continuous

Bowl diameter: 100 mm

Temp. range: -40°/+60°C (-40°/+158°F)

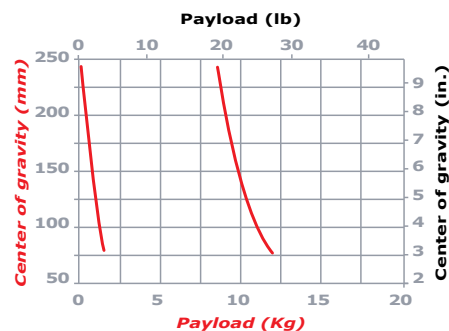

accessories ■

D 733



A 841/A



C 928





The **HiDV Fluid Head** is the ideal support for the latest DV cameras weighing from up to 6 Kg (13 lbs). Extremely compact and lightweight the **HiDV** features a continuously variable fluid damping system on both pan and tilt movements and an unprecedented **CARTONI** patented **variable counterbalance** which brings its range of use to cover all existing DV cameras.

The **HiDV** Fluid Head comes equipped with a quick release sliding camera plate, spirit level and orientable pan bar. The **HiDV**'s tilting angle is +/- 90° with perfect response throughout the entire tilt range.

It interfaces with all 75mm bowl base tripods and supports. The extreme ruggedness and versatility together with a superb quality/price ratio make the **HiDV** the best possible support for DV videographers.

■ specifications

Payload capacity:	0-6 Kg (0-13 lbs)
Weight:	1,8 Kg (4 lbs)
Pan range:	360°
Tilt range:	+/- 90°
Counterbalance:	Continuous
Fluid drag:	Continuous
Bowl diameter:	75mm
Temp. range:	-40°/+60°C (-40°/+158°F)



accessories ■

D 733



T 626/2



C 928

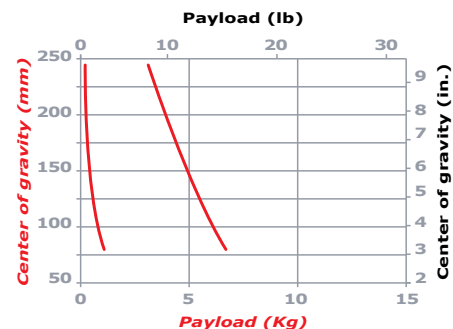

STATUS Pro, the fast & reliable new Professional **VIDEO FLUID HEAD** from **CARTONI** is the ideal support for the latest camcorders weighing from 0 to 5 Kg (0 to 11 lbs). Extremely compact and lightweight the **STATUS Pro** features a Patented continuously variable fluid damping system on both pan and tilt movements and a positive counterbalance switchable in 3 progressive steps + 0, which brings its range of use to cover most of the existing compact DV & HDV cameras.

The **STATUS Pro** Fluid Head comes equipped with a quick release sliding camera plate, spirit level and orientable pan bar. Its tilting angle is + 90° / -85°, with a perfect response throughout the entire tilt range.

It interfaces with all 75mm bowl base tripods and supports. The extreme ruggedness and versatility together with an great quality price ratio, makes the **STATUS Pro** the best possible support for DV & HDV videographers.

■ specifications

Payload capacity: 0-5 Kg (0-11 lbs)

Weight: 1,7 Kg (3.7 lbs)

Pan range: 360°

Tilt range: +90° / -85°

Counterbalance: 3 steps + 0

Fluid drag: Continuous

Bowl diameter: 75mm

Temp. range: -40°/+60°C (-40°/+158°F)

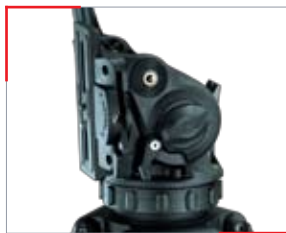
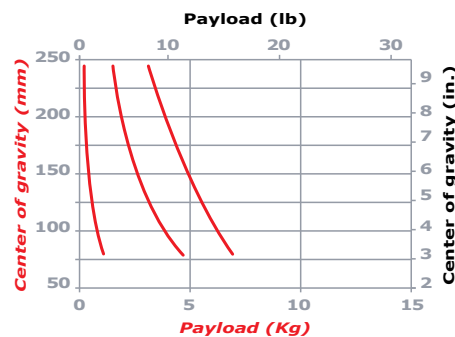

accessories ■

D 733



T 626/2



C 928





Extremely versatile, the **CARTONI P90** two-stage pedestal is designed to support camera/lens combination up to 90 Kg, covering the entire range of **STUDIO** and **OB** configurations.

The system is compact and portable, the 2-stage column performs an on-shot stroke of 77 cm with a smooth and precise movement.

The sturdy and yet lightweight dolly is equipped with high precision double wheels interlocked by a special designed chain allowing accurate travelling and steering, even on shot.

The **CRAB POSITION** is also available for narrow door ways. All operating devices and control displays are at the cameraman easy access. The pneumatic column works on simple compressed air which can be loaded with a compressor or a simple hand pump. The piston innovative design avoids complicated balance setting and no counterweights are needed.

The system interfaces with all flat base, 4-bore holes heads or any other bowl based head with an adapter.

Available in "classic black" - Special order only.

■ specifications

Maximum pressure: **13.0 atm (187 psi)**

Maximum capacity: **90 Kg (198 lbs)**

Total weight: **60 Kg (132 lbs)**

"on-shot" stroke: **74 cm (29")**

Steering wheel diameter: **57,5 cm (22,6")**

Minimum height: **72 cm (28,9")**

Maximum height: **146 cm (57,5")**

Wheel diameter: **125 cm (49,2")**

Doorway tracking width: **80 cm (31,4")**

Dolly leg radius: **47,5 cm (18,7")**

Column weight: **30 Kg (66 lbs)**

Dolly weight: **30 Kg (66 lbs)**

P50 is a portable and compact system for both **STUDIO** and **OB** applications. Extremely stable yet lightweight, its ideal performance is reached with camera/lens combination of around 45 kg (100 lbs). In the **P70** version the payload capacity is extended to 65 Kg (145 lbs).

The air filled, one shot column is fast and safe to operate: the air can be set in manually or by compressor, and a safety air pressure valve prevents danger of over pumping. The innovative column design provides outstanding stability end jerk-free control with exceptional smoothness and precise movements.

The column supports a maximum payload of 55 kg (121 lbs) at 180 psi and the safety valve is adjusted at maximum 250 psi.

On the foldable dolly, six position track lock, foot operated brake on each of the 125mm twin wheels and cable guards provide smooth movements in any desired direction.

The column is firmly secured to the dolly by a double clamp, easily engaged by two ergonomic locking levers. A set of 200mm **PNEUMATIC TIRES** with wheel brakes are available for OB use.

■ specifications

Maximum pressure **P50**: 17.0 atm (250 psi)

Maximum pressure **P70**: 12.2 atm (175 psi)

Maximum capacity **P50**: 55 Kg (121 lbs)

Maximum capacity **P70**: 65 Kg (145 lbs)

Total weight: 28 Kg (62 lbs)

Total weight: 28 Kg (62 lbs)

"on-shot" stroke: 50 cm (19,7")

Dolly leg radius: 50 cm (19,7")

Steering wheel diameter: 45 cm (17,7")

Minimum height: 75 cm (30")

Maximum height: 140 cm (55,1")

Wheels: 3 x 2 coupled

Wheel diameter: 125 mm (4,5")

Doorway tracking width: 100 cm (39,4")



accessories ■

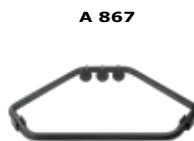

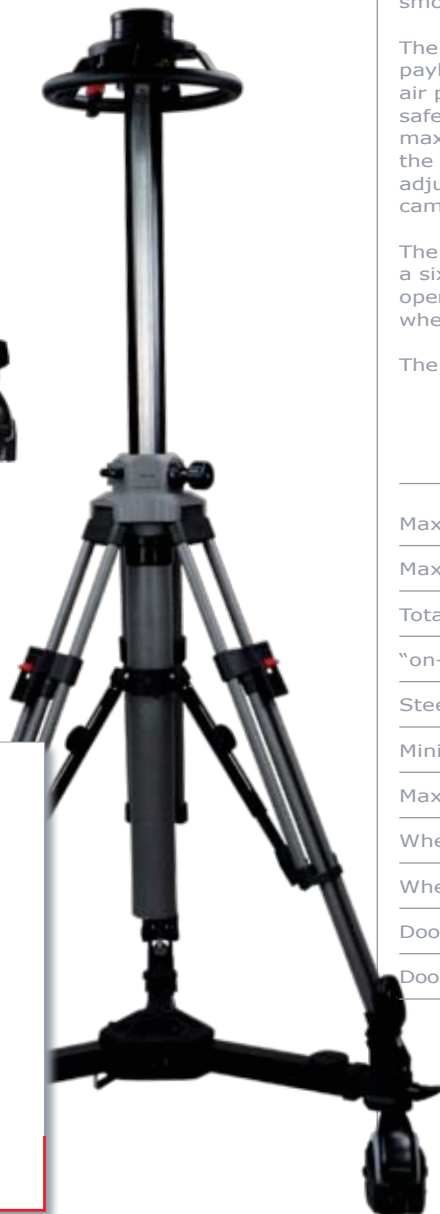

accessories

A 866

A 869



Extremely compact and lightweight, this **INNOVATIVE PEDESTAL** is the ideal mate for mobile work and lightweight studio needs.

The same technical concept which has made the **P50** so successful is performed in the **CARTONI P20**, an extremely rugged and precise dolly and a pneumatic column for maximum stability, smoothness and jerk-free operation.

The column supports a maximum payload of 25Kg (55 lbs) it includes an air pressure gauge, locking brake and safety air pressure valve adjusted at maximum 187 psi. The air pressure inside the column can be set in manually and adjusted to suit the exact weight of the camera configuration.

The foldable and extensible dolly features a six-position **TRACK LOCK**, foot operated brake on each of the 100mm wheel and cable guards.

The system includes a manual air pump.

specifications

Maximum pressure: **13.0 atm (187 psi)**

Maximum capacity: **25 Kg (55 lbs)**

Total weight: **14 Kg (31 lbs)**

"on-shot" stroke: **40 cm (15,7")**

Steering wheel diameter: **26 cm (10,2")**

Minimum height: **74 cm (29")**

Maximum height: **161 cm (63,3")**

Wheels: **3 x 2 coupled**

Wheel diameter: **100mm (3,9")**

Doorway tracking width min.: **67 cm (26,3")**

Doorway tracking width max.: **97 cm (38,1")**

ELEVATION UNIT

This sturdy support is suitable for both Studio and Maxi tripods, and combines the height range advantages of a standard pedestal with the low cost, robustness and fast operation of a tripod.

Weighing only 4 Kg (4,4 lbs), it features a maximum elevation height of 35 cm (14") and can be easily mounted on any existing platform equipped with the 4-holes bore.



A 881



T 625/R



T 624/M

T 624/BM

T 624/2M



T 625



T 625/M

OB & STUDIO TRIPODS

With its rugged construction and extraordinary sturdiness the Cartoni Studio and Maxi tripods are designed to support the larger Fluid Heads in Studio or Outside Broadcast configuration.

A special care has been developed in achieving torsional rigidity and positive leg clamp. The tripod series feature both flat Mitchell style bases including the 4 hole bores and 150mm bowl base.

The ground steel spikes are covered by adjustable rubber feet and each tripod can be secured either by an integral off ground spreader or by a variety of ground spreaders and skids.

3-WAY LEVELLER HD TRIPOD

A unique Heavy Duty tripod with flat Mitchell base and 3-way levelling ability for horizontal fine tuning. The innovative concept allows mounting all flat Mitchell base heads and still be able to correct horizontal plan without acting on the legs height and without compromise for torsional rigidity.



Product code	T624 T624/M	T624/2 T624/2M T624/2C T624/2CM	T624/BM	T624/S	T625	T625/S
Type	1 stage	2 stages	1 stage baby	1 stage	1 stage	1 stage baby
Material	aluminum	alu/carbon fiber	aluminum	aluminum	aluminum	aluminum
Weight	7,4kg/16,3lbs	6,5kg/15,5lbs alu 6kg/13lbs carbon f.	5,7kg/12,8lbs	5,6kg/2,6lbs	10kg/23lbs	8,9kg/19,6lbs
Capacity	150kg/330lbs	150kg/330lbs	150kg/330lbs	150kg/330lbs	200kg/440lbs	200kg/440lbs
Base	flat/150mm	flat/150mm	flat/150mm	flat/150mm	flat/150mm	flat/150mm
Min. height	80cm/35,5"	50cm/22,2"	52cm/23"	32cm/14,2"	72cm/32"	46cm/20,4"
Max. height	155cm/68"	163cm/72"	65cm/28,8"	45cm/20"	130cm/57,7"	79cm/35"
Folded height	95cm/42,2"	75cm/33"	55cm/24,4"	35cm/15,5"	89cm/39,5"	58cm/25,7"

flip-clamping
system

T 623/2



T 623

EFP TRIPODS

Stable and sturdy, though lightweight, the Cartoni EFP series tripods are available in one or two stages and both in aluminum and carbon fiber.

The 100mm bowl base is connected to the three legs with a performing system of elastic washers and self adjusting steel connection which guarantees virtually no torque effect even with heavy drag fluids.

Height adjustment is performed by a fast clamp, and includes a safety lock to prevent accidental falls.

The bottom foot includes a threaded spike, receiving the adjustable rubber foot and interfaces with dollies and ground spreaders.



A 857

Product code	T623 T623/C	T623/2 T623/2C	T623/B	T623/S
Type	1 stage	2 stages	1 stage baby	1 stage short
Material	alu/carbon fiber	alu/carbon fiber	aluminum	aluminum
Capacity	80kg/176lbs	80kg/176lbs	80kg/176lbs	80kg/176lbs
Weight	3,4kg/7,5lbs 3,3kg/7,2lbs	3,8kg/8,3lbs 3,6kg/8lbs	2,7kg/5,9lbs	2,10kg/4,6lbs
Base	100mm	100mm	100mm	100mm
Min. height	67,5cm/30"	54cm/24"	50cm/22,2"	30cm/13,3"
Max height	144cm/64"	157cm/70"	64cm/28,4"	44cm/19,5"
Folded height	85cm/37,7"	75cm/33,3"	54cm/24"	34cm/15"

ENG TRIPODS

Lightweight and extreme stability, together with a fast display in action, are the main features of the ENG tripods.

Available in three versions: the basic 3 tubes, the classic ENG one stage and the double stage, all available in lightweight aluminum or ultra-light carbon fiber.

Height adjustment is performed by a fast, easy to reach clamp and includes a safety lock to prevent accidental falls.

The bottom foot includes a threaded spike receiving the adjustable rubber foot and interfaces with dollies and ground spreaders.



T 626/2



T 622



S 731 QR



T 621

Product code	T621	T626/2	T622 T622/C	T622/2 T622/2C	T622/B	T622/S
Type	1 stage/3 tube	2 stage/3 tube	1 stage	2 stage	1 stage baby	1 stage short
Material	aluminum	aluminum	alu/carbon fiber	alu/carbon fiber	aluminum	aluminum
Capacity	40kg/88lbs	40kg/88lbs	60kg/132lbs	60kg/132lbs	60kg/132lbs	60kg/132lbs
Weight	2,1kg/4.6lbs	3kg/6,6lbs	2,8kg/6,2lbs 2,7kg/5,9lbs	3,2kg/7lbs 3kg/6,6lbs	2,3kg/5,1lbs	1,8kg/4lbs
Base	75mm	75mm	100mm	100mm	100mm	100mm
Min. height	78cm/34,6"	67cm/26,4"	74cm/32,8"	51cm/22,6"	42cm/18,6"	30cm/13,3"
Max. height	136cm/60,4"	151cm/59"	137cm/53,9"	162cm/72"	77cm/34,2"	44cm/19,5"
Folded height	84cm/37,3"	77cm/30,3"	81cm/31,9"	74cm/32,8"	56cm/24,8"	34cm/15"



SmartStop

T 628/2
SmartStop
eng tripod

T 627



SmartStop

Product code	T627 T627/C	T627/2	T628/2 T628/2c
Type	1 stage/3 tube	2 stage/3 tube	2 stage
Material	alu/carbon fiber	aluminum	alu/carbon fiber
Capacity	50kg/110lbs	50kg/110lbs	60kg/132lbs
Weight	2,9kg/6,4lbs	3,3kg/7,2lbs	3kg/6,6lbs
Base	100mm	100mm	100mm
Min. height	75cm/33,3"	51cm/22,6"	51cm/22,6"
Max. height	141cm/62,6"	162cm/72"	162cm/72"
Folded height	87cm/38,6"	74cm/32,8"	74cm/32,8"

S 708
mid level spreader



S 731/QR
mid level spreader



S 738
studio spreader



D 733
lightweight dolly

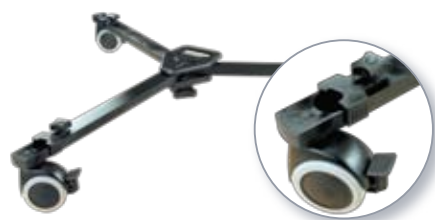

S 731/SML
multi level spreader



S 732
standard ground spreader



S 732/HD
heavy duty spreader



D 734
standard dolly



S 731/SQR
mid level spreader



S 732/F
flexible ground spreader



S 732/HDML
heavy duty mid level spreader



D 734/A
extendable dolly



D 737
studio dolly



A 847
100mm hi-hat



A 869
100mm head adapter to P20



A 935
adapter for pedestal



A 950
100/75mm reduction ring



A 891
3-way leveller



A 852
45° wedge plate



A 907
mitchell nut flat base



A 936
8" european attachment



A 849
150mm bowl base converter



A 845
100mm bazooka basket



A 863
100mm head adapter to P50



A 856
flat base 4-bore holes adapter



A 854
150-100mm reduction ring



A 849/M
150mm bowl base converter



- **A 857**
pivoting rubber foot dv/eng/efp
tripods



- **A 890**
lambda 3-axis hand-wheel



- **A 883 L**
lambda counterweight



- **A 867**
P50 foot ring



- **A 864**
lambda camera plate



- **A 865**
pivoting rubber foot hd tripods



- **A 882**
lambda short pan bar



- **A 850/L**
lambda eye piece
extension holder



- **A 858 / A 859**
eng camera plate



- **A 868**
C60/omega dovetail plate



- **A 908**
pivoting rubber foot studio
tripods



- **A 940**
P50 pneumatic wheels



- **A 850/MS**
master/sigma eye piece
extension holder



- **A 860**
efp camera plate



- **A 884**
removable universal plate



A 932
master camera plate



A 858/D
inverted camera plate
spinhead & smarthead



A 930
sigma short pan bar



C 911
dutch head fly case



C 912
pvc transport tube



A 933
master quick release plate



A 904
long camera plate
spinhead & smarthead



A 951
fast lock base



A 920
lambda fly case



C 928
light soft bag



A 895
sigma HD plate



A 850/C4 & A850/C2
C20S/C40S eye piece
extension holder



A 901
eng shoulder mount



C 925
sigma fly case



C 929
hard bag with wheels

