

**HYBRID FIBER-OPTIC SPLICE ENCLOSURE**

Mode	Mo. of cables	Fusion splice tray No.	Adapter	
			SC	Nylon connector
FCE-2	2	1	4	2
FCE-4	4	2	8	4
FCE-6	6	3	12	6

\*Special Order

- Designed for the hybrid fiber-optic camera cable (LF-2SM9)
- The enclosure can be installed on walls or placed flat.
- The tension member is installed from the chassis.

Note: The following special tools are required for installing the nylon connectors.  
Models: AMP90758-1 (26 to 22 AWG) and AMP90760-1 (18 to 20 AWG)



Above parts are for FCE-2.

Type	FCE-2	FCE-4 FDC-6
A	170	240
B	160	230
C	150	220
D	126	196

(mm)

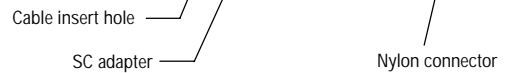
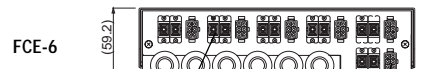
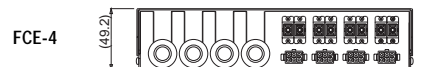
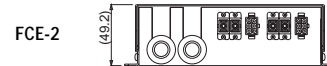
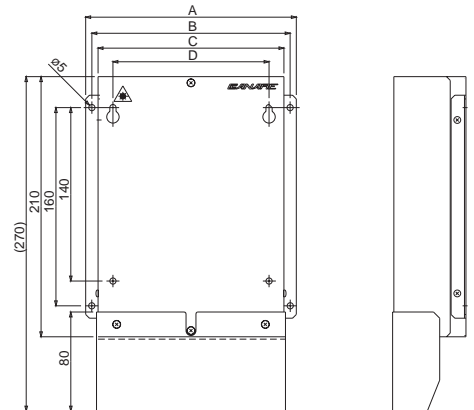

**• Wiring Diagram (Canare standard)**

