

CANARE



Audio/Video

Cable

Connectors

Patchbays

Snake Systems

Cable Reels

VIDEO PATCHBAYS & BULKHEAD PANELS

75Ω DIGITAL VIDEO JACKS & WE PATCH PLUGS	4-5
75Ω DIGITAL VIDEO PATCHBAYS & WE PATCHCORDS	6-7
A/V BULKHEAD PANELS	8-9

CONNECTORS

75Ω BNC CRIMP PLUGS	10-11
75Ω BNC BULKHEAD RECEPTACLES	12
75Ω BNC TERMINATOR, ISO BUSHINGS, PC MOUNT BNC	13
75Ω F RECEPTACLES	14
75Ω F CRIMP PLUGS	15
75Ω TYPE RCA BULKHEAD RECEPTACLES	16
75Ω TYPE RCA CRIMP PLUGS	17
TOOLS, DIES, CABLE STRIPPERS	18
CABLE BOOTS, BNC REMOVAL TOOL, CABLE STORAGE RACK	19
AUDIO CONNECTORS	20
110Ω-75Ω DIGITAL AUDIO IMPEDANCE TRANSFORMERS	21

CABLE

75Ω SERIAL DIGITAL VIDEO CABLE	22
75Ω MULTICHANNEL DIGITAL VIDEO CABLE	23
75Ω VIDEO CABLE	24
75Ω MULTICHANNEL VIDEO CABLE	25
STAR QUAD AUDIO CABLE	26-27
STAR QUAD MULTICHANNEL AUDIO CABLE	28
AUDIO CABLE	29
GUITAR / KEYBOARD CABLE	30
SPEAKER CABLE	31
AUDIO + VIDEO COMPOSITE CABLE	32
DIGITAL AUDIO & DATA CABLE	33

CABLE REELS, SNAKES & ASSEMBLIES

CABLE REELS	34
AUDIO SNAKE SYSTEMS	35-37
RGB VIDEO SNAKES	38
BROADCAST VIDEO LINE CORDS	39
A/V PATCH CORDS	40
STAR QUAD MICROPHONE CORDS	41
'QUICK LOOK' MODEL LISTING & TECH TERMS ABBREVIATION TABLE	42

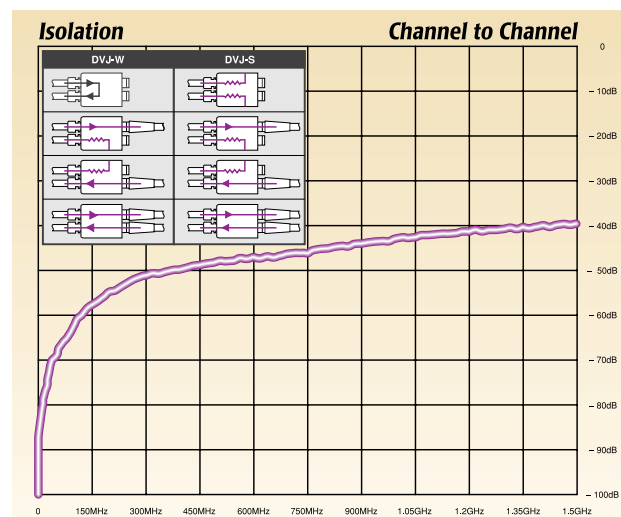
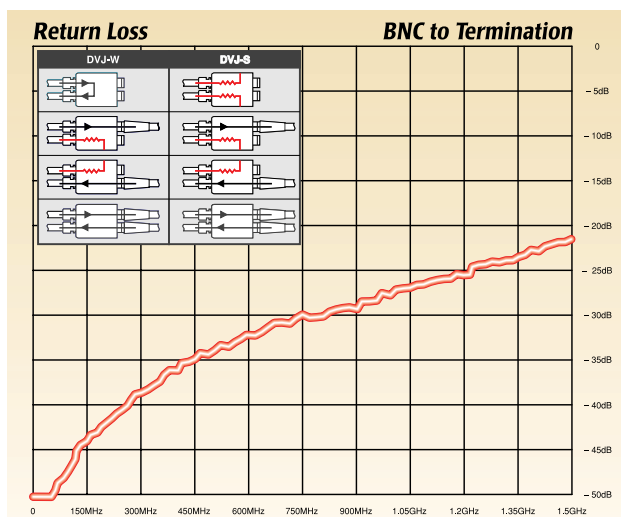
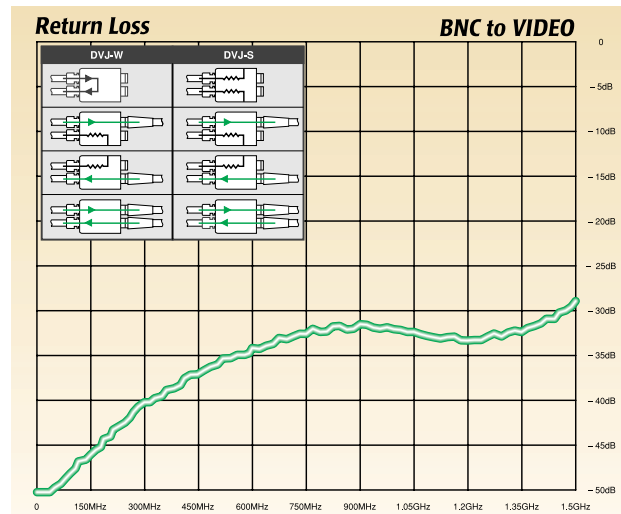
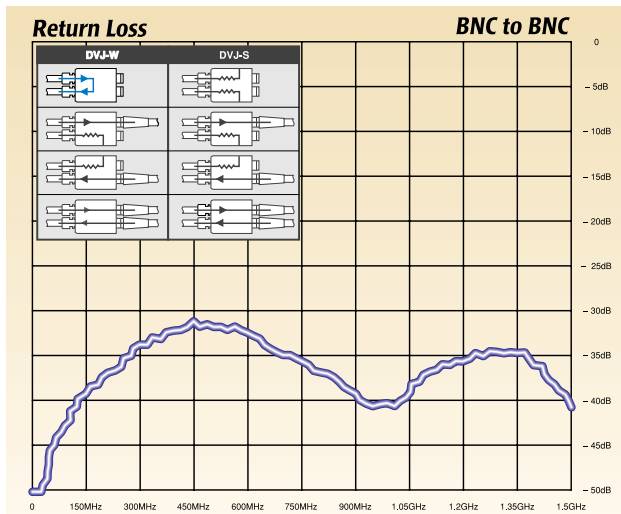

Note: The above charts illustrate signal flow for every critical Patch Point. It is important to note that Canare alone chooses to publish nominal RETURN LOSS and CHANNEL ISOLATION characteristics for all four (4) insertion states, not just at the best presented pass through circuit point.

DVJ-W & DVJ-S NOMINAL SPECIFICATIONS

DESCRIPTION

Impedance 75Ω
Video Port Center Conductor WE (.09in)
Weight 2.4oz (67g)

MATERIALS

Switch Type Sealed MicroSwitch
75Ω Resistor ±0.5%, 1/8 watt
Center Contact Material/Plating Beryllium Copper/Gold
Actuator Arm Material/Plating Phosphor Bronze/Nickel
Body Shell Material/Plating Die Cast Aluminum/Nickel
Dielectric Materials Zeonex / Noryl

MECHANICAL

Insertion Cycle Rating 30,000 I/O Matings
Plug Withdrawl Force 700g-1500g

ELECTRICAL

Bandwidth DC-720MHz ≤1.1 VSWR ; ≥26dB RL
Bandwidth 720MHz-1.5GHz ≤1.2 VSWR ; ≥20dB RL
Isolation DC-720MHz ≥45dB
Insertion Loss DC-720MHz ≤0.4dB
Outer Contact Resistance ≤5mΩ
Center Contact Resistance BNC-BNC ≤400mΩ
Center Contact Resistance BNC-VIDEO ≤100mΩ
Insulation Resistance at 250V DC ≥500MΩ
Voltage Rating for 1 minute 400V AC (rms)

ENVIRONMENTAL

Temperature Range -10°C to 70°C
Thermal Shock no abnormalities;
 10 cycles @ -40°C & 85°C
Humidity Range 0% to 85%

LIFETIME WARRANTY STATEMENT

Canare warrants that the DVJ-W and DVJ-S will be free from defects in materials and workmanship for as long as these products remain in use. Canare will replace, or repair, at its option, products which are proven to be defective. This warranty does not apply to any products that have been subject to misuse, improper storage, or incorrect installation or servicing. At Canare's option, Canare may replace any defective product with the same or similar product. This warranty is void if the product Label has been tampered with or removed. This warranty is in lieu of all other warranties, express or implied, including (but not limited to) any warranty of fitness for a particular purpose or warranty of merchantability. This warranty states the full extent of Canare's liability resulting from any breach, and in no event shall Canare be liable for indirect, consequential or special damages (including, but not limited to, lost profits) sustained by any party as a result of a breach of this warranty.

APPLICATIONS

- Serial Digital Video (SDI)
- Analog Baseband Video
- HDTV Upgrades (DTV)
- Satellite Headends
- CATV Broadband
- SMPTE 276M/AES3 Digital Audio

KEY FEATURES

- DC-1.5GHz Digital Bandwidth
- Sealed Microswitch Contacts
- 30,000 Insertion Cycles
- Rear Mount/Front Screws
- Color Label ID
- Lifetime Warranty

Canare 75Ω Dual Video Jacks are designed for transmission ranges from NTSC baseband analog video to Serial Digital Video (HDTV) frequencies, not just in normal pass through mode, but at all four patch point insertion states.

To prevent dirt, dust and other airborne contaminants from entering the Jacks and damaging internal components, the DVJ-W and DVJ-S employ rugged aluminum clam shell housings. Both models incorporate high grade, hermetically sealed, double reverse action microswitches, strategically mounted on a shielded printed circuit board.

Two precision 75Ω metal film resistors offer near perfect signal path termination and superior channel isolation.

We've eliminated the annoying hassle of dropped set screws behind the rack bay enclosure by fastening our DVJ's at the front side of Patch Panel.

Canare Digital Video Jacks will perform to spec for years of trouble-free operation thanks to precision engineering, extremely tight manufacturing tolerances, technical "know-how" and consistent attention to every design detail.



DVJ-W Normal Through

Signal routes between top and bottom BNC without the use of external looping plugs. Inserting a Canare VPC Video Patch Cord into either front WE port automatically terminates signal path into a 75Ω load. Our most popular DVJ model.

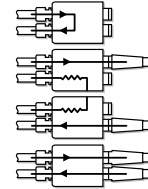

DVJ-S Straight Through

Two independent single jacks in a dual housing. Inserting a Canare VPC Video Patch Cord into either front WE port breaks the 75Ω termination for straight signal pass through. Very useful for bringing up auxiliary equipment to a designated central patchbay location.

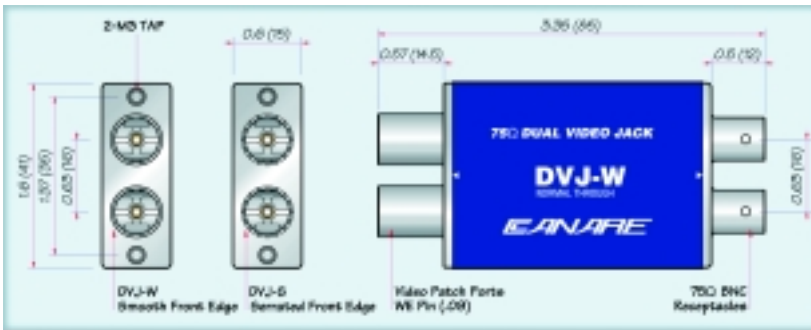
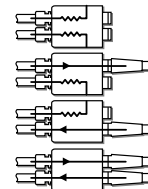

CIRCUIT IDENTIFICATION

The DVJ-S straight through jack has a unique **serrated** front port entry (see above diagram). Finally, a video technician standing in front of the patchbays can easily differentiate between a Normal thru jack (DVJ-W smooth port edge) or a Straight thru jack (DVJ-S serrated port edge) by sight or touch.

We have also conveniently color coded the protective wraparound label and clearly printed the model number on the top rear side of the jack, allowing visual circuit ID from behind the racks.

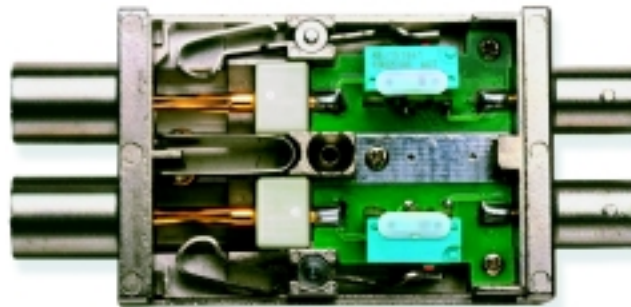

MICROSWITCH CONTACTS

All Canare 75Ω Digital Video Jacks use specially selected high grade double reverse action microswitches, strategically mounted on a shielded printed circuit board. You get superior channel isolation and consistent reliability from extended contact life of 30,000 input/output cycles. Canare Dual Video Jacks will perform to specification even in humid and dusty environments.

75Ω WE VIDEO PATCH CRIMP PLUG

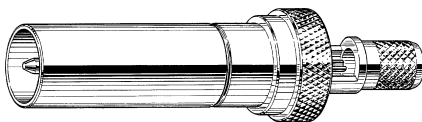

VWP-C44

Cable:	LV-61S
Boot:	CB04
Crimp Die:	TCD-451C

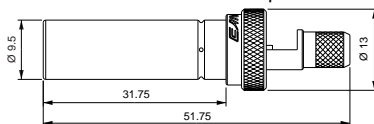
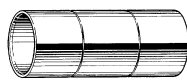

DC to 1.5GHz ≥20dB Return Loss, matches the electrical and mechanical performance of our DVJ-W and DVJ-S Digital Video Jacks.

WE (WE.090") gold plated center contact is also compatible with older Canare VWJ2 series Video Jacks. Solder pin, Crimp Sleeve.

75Ω WE VIDEO PATCH PLUG TO BNC ADAPTER

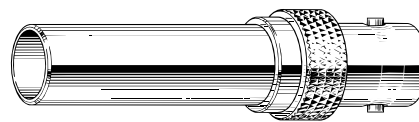

BCJ-VWP

Contacts:	Beryllium Copper Gold Plating
Body:	Brass Nickel Plating
Dielectric:	PTFE

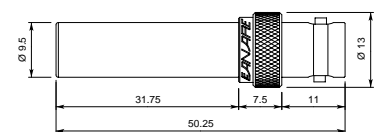

DC to 1.5GHz ≥20dB Return Loss. WE (WE.090") gold plated center contact pin. Video Patch to 75Ω BNC female jack. Use with any Canare BNC Broadcast Video Patch Cords.

APPLICATIONS

- DIGITAL VIDEO BROADCAST (SDI)
- ANALOG VIDEO (NTSC)
- SATELLITE HEADENDS
- HDTV SYSTEMS (DTV)
- OB VANS
- BROADBAND TELCOM

KEY FEATURES

- 1RU, 2RU or 4RU Panels
- 20, 24 or 26 across loading
- Normal & Straight Dual Jacks
- 75Ω Self-Terminating
- Easy Front Mount Assembly
- Reduced Weight
- Extra Wide Designation Strips

EASY CIRCUIT ID

Canare Digital Video Jacks employ a unique Color Coded wraparound label (Blue-Normal, Gray-Straight) for easy Jack identification and model number call-outs behind the racks.

Serial Digital Video (SDI) production equipment operates at super high data bit rates. Every interconnect component in the modern post facility must be checked for 75Ω matched impedance and have sufficient headroom to pass HDTV signals in excess of 720MHz.

The Video Patchbay is a vital link in your signal distribution network scheme. Used as a supplement to routing switchers or as the primary stand-alone component for cost effective switching, the Video Patchbay must perform routine operations as well as handle real life emergencies, where any downtime is unacceptable.

Canare 75Ω Digital Video Patchbays are designed for maximum reliability and will pass all Serial Digital signal formats with excellent Return Loss characteristics and very few signal reflections (VSWR).

SPECIAL APPLICATION NOTE

Any standard 1/4 Longframe Audio Jack can be easily mounted to the back of our Video Patch Panels. This feature permits you to install a very cost effective and convenient Audio+Video combination patchbay.

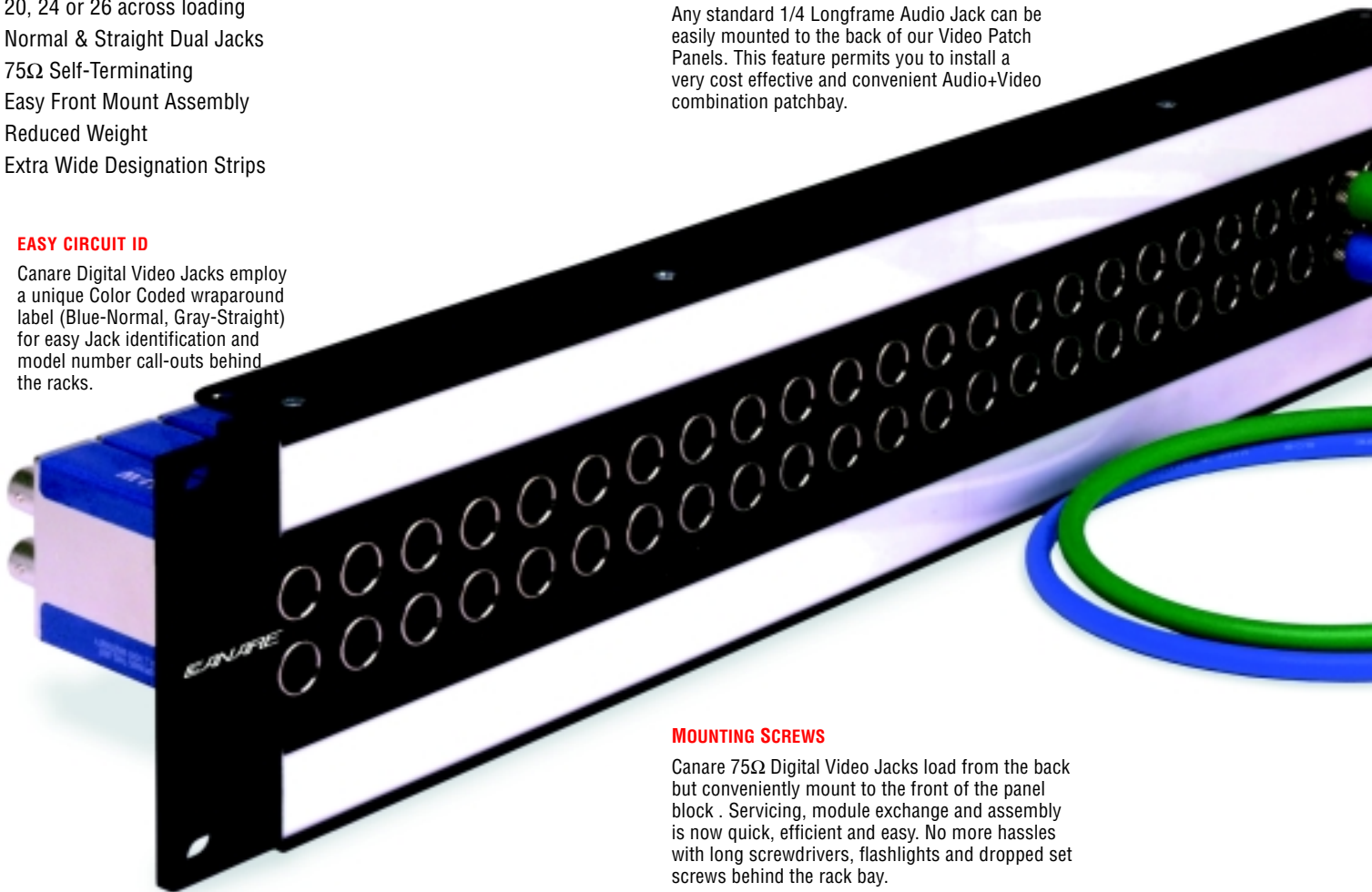

MOUNTING SCREWS

Canare 75Ω Digital Video Jacks load from the back but conveniently mount to the front of the panel block. Servicing, module exchange and assembly is now quick, efficient and easy. No more hassles with long screwdrivers, flashlights and dropped set screws behind the rack bay.

NEW!

LP-1 LOOPING PLUG

New 75Ω U-Link is the perfect way to quickly manually normal the input & output on our **DVJ-S** straight-through Digital Video Jack. You get 1.5GHz ($\geq 20\text{dB}$ Return Loss) impedance matched performance.

WE (WE.090") gold plated center contacts. Can be conveniently used with all Canare 1RU, 2RU and 4RU Video Patchbay Panels.

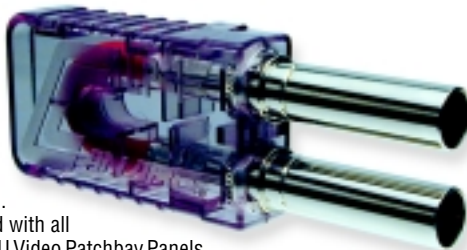

LP-1 COLORS AVAILABLE

BLK	BLU	BRN	GRY	GRN	ORN	PPL	RED	WHT	YEL



PANEL CONSTRUCTION

Each Panel is machined from a single solid block of 19 inch wide lightweight phenolic material. A smooth textured black suede laminate is applied to the front face for a durable non-scratch surface and enhanced rack appearance.

LOADED PATCH PANEL SPECIFICATIONS

Loaded Panel Model	Rack Panel Height	DVJ Circuit Type	Row Config	*Jack Model	DVJ Qty	Patch Points	Blank Panel
201U-DVJW	1RU	Normal	2 x 20	DVJ-W	20	40	VJ2-E20
241U-DVJW	1RU	Normal	2 x 24	DVJ-W	24	48	VJ2-L24-1U
261U-DVJW	1RU	Normal	2 x 26	DVJ-W	26	52	VJ2-L26-1U
242U-DVJW	2RU	Normal	2 x 24	DVJ-W	24	48	VJ2-L24-2U
262U-DVJW	2RU	Normal	2 x 26	DVJ-W	26	52	VJ2-L26-2U
244U-DVJW	4RU	Normal	6 x 24	DVJ-W	72	144	VJ2-E24-4U
264U-DVJW	4RU	Normal	6 x 26	DVJ-W	78	156	VJ2-E26-4U

*Canare 75Ω Digital Video Patchbays can be custom ordered with all DVJ-S jacks (ex: 261U-DVJS), partially loaded or with any specified Normal & Straight Jack combinations.

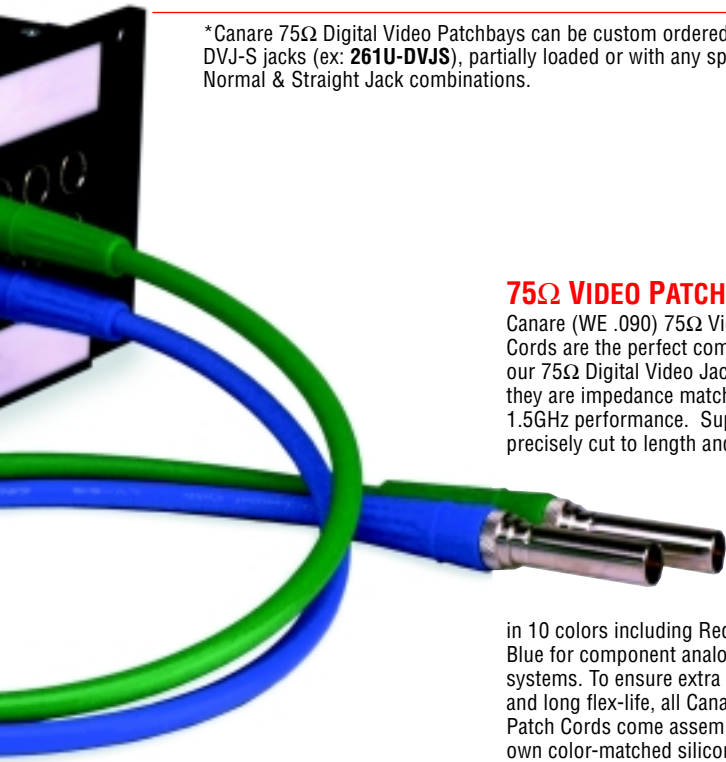

75Ω VIDEO PATCH CORDS

Canare (WE .090) 75Ω Video Patch Cords are the perfect compliment to our 75Ω Digital Video Jacks because they are impedance matched for 1.5GHz performance. Super flexible, precisely cut to length and available

in 10 colors including Red, Green and Blue for component analog video systems. To ensure extra reliability and long flex-life, all Canare Video Patch Cords come assembled with our own color-matched silicon rubber cable stress relief boot.

75Ω VIDEO PATCH CORDS				
Model	Lng.	75Ω Coax Cable	75Ω Video Plugs	Color Boot
VPC002F	2ft	LV-61S	VWP-C4A	CB04
VPC003F	3ft			
VPC006F	6ft			

VPC COLORS AVAILABLE									
BLK	BLU	BRN	GRY	GRN	ORN	PPL	RED	WHT	YEL
■	■	■	■	■	■	■	■	■	■



HIGH DENSITY 20 ACROSS PATCHBAYS

Choose our 2x26 one rack unit (1RU), 2x26 two rack unit (2RU) or our ultra high density 6x26 four rack unit (4RU) Jack Panels. Perfect choice for Master Control, Headends, Edit Suites, small Production Studios, OB Vans or anywhere rack space is at a premium.

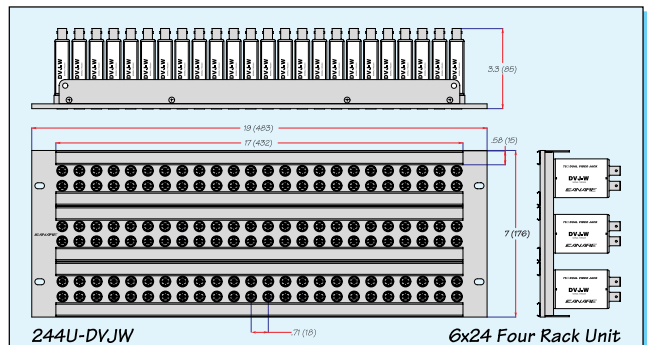
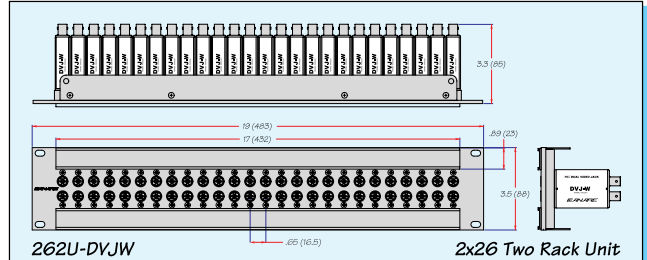
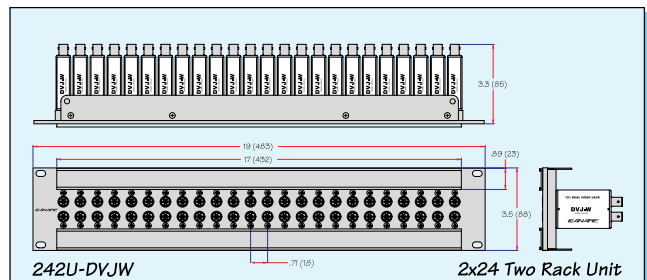
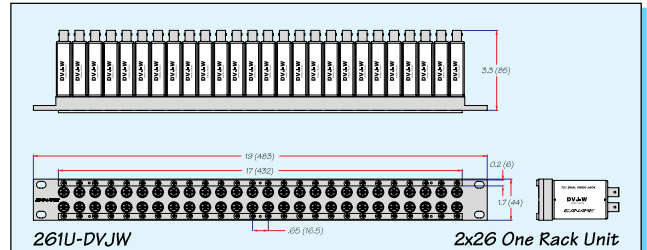
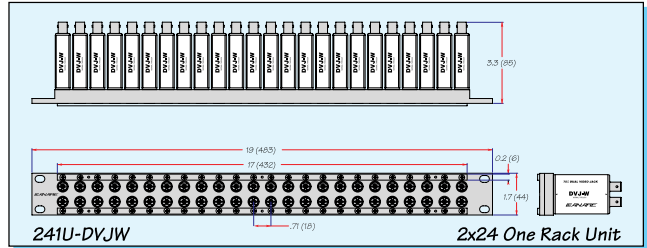
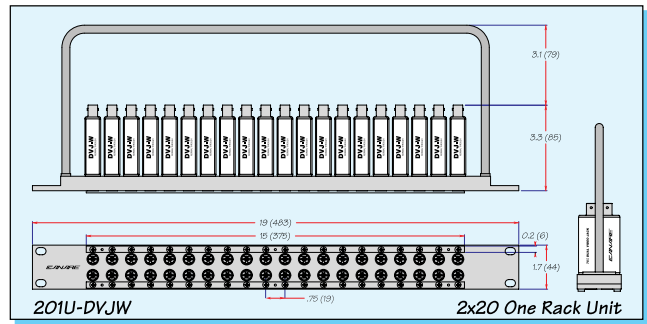

APPLICATIONS

- HEADENDS
- MULTIMEDIA EDIT SUITES
- MASTER CONTROL ROOMS
- SATELLITE
- TELCOM
- BROADBAND

FEATURES

- Isolated BNC, RCA, F, XLR on Same Panel
- Flush Mount or Standoff style Connectors
- Strong 16 gauge Cold Rolled Steel (1.62mm) Panel
- Top & Bottom Panel Reinforcement Folds
- Matte Black Powder Coat Panel Finish
- Tapped Screw Holes for Connector Mounts
- Clear Plastic Desi-Strips & Channel ID Numbers

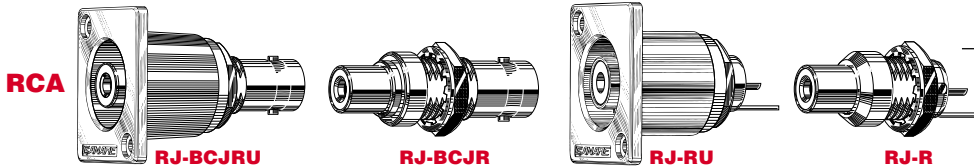
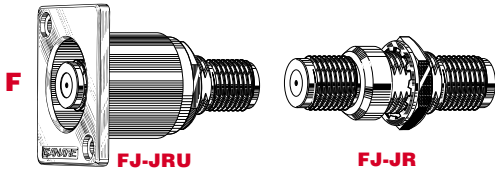
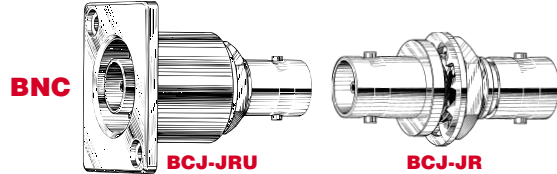
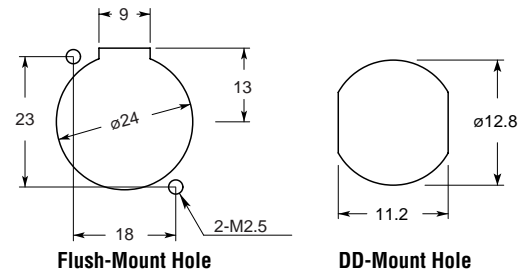

Model Selection Guide

16 1U - BJRU

Connector Qty
16, 32

Panel Height
1U = 1 Rack Unit;
19" x 1.7"
2U = 2 Rack Unit;
19" x 3.5"

Connector Model	Type	(Panel Style)
BJR = BCJ-JR	75Ω BNC - BNC	(Iso Standoff)
BJRU = BCJ-JRU	75Ω BNC - BNC	(Flush Mount)
FJR = FJ-JR	75Ω F - F	(Iso Standoff)
FJRU = FJ-JRU	75Ω F - F	(Flush Mount)
RJS = RJ-R	75Ω RCA - Solder	(Iso Standoff)
RJBR = RJ-BCJR	75Ω RCA - BNC	(Iso Standoff)
RJSU = RJ-RU	75Ω RCA - Solder	(Flush Mount)
RJBURU = RJ-BCJRU	75Ω RCA - BNC	(Flush Mount)
X1 = XLR3-31F77	Female XLR - Solder	(Flush Mount)
X2 = XLR3-32F77	Male XLR - Solder	(Flush Mount)
X12 = XLR3-31/32F77	M&F XLR - Solder	(Flush Mount)

Custom Iso Bushing Colors: BLK, BLU, GRN, RED, YEL

BNC • STANDOFF

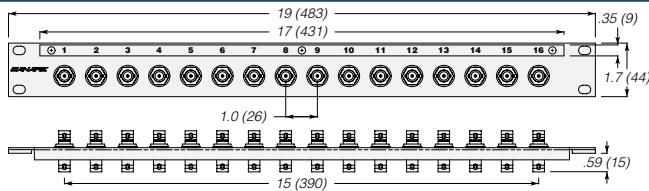

161U-BJR

16ea 75Ω BNC-BNC Barrel Jacks
Iso Bushing: WHT

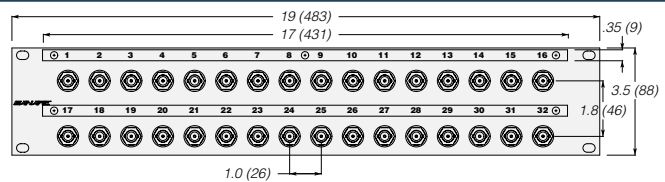

322U-BJR

32ea 75Ω BNC-BNC Barrel Jacks
Iso Bushing: WHT

F • STANDOFF

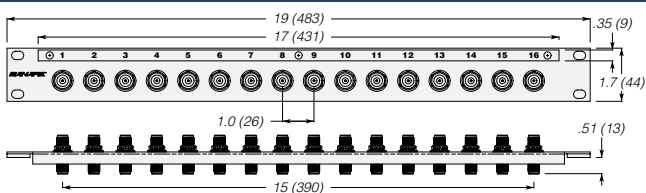

161U-FJR

16ea 75Ω F-F Barrel Jacks
Iso Bushing: WHT

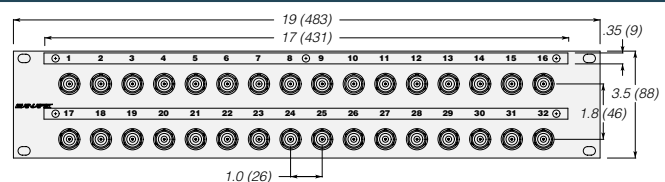

322U-FJR

32ea 75Ω F-F Barrel Jacks
Iso Bushing: WHT

BNC • FLUSH MOUNT

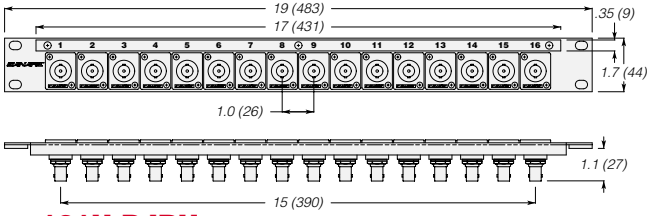

161U-BJRU

16ea 75Ω BNC-BNC Jacks

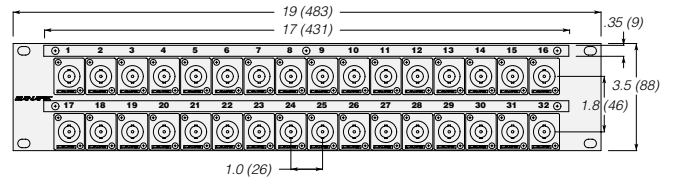

322U-BJRU

32ea 75Ω BNC-BNC Jacks

F • FLUSH MOUNT

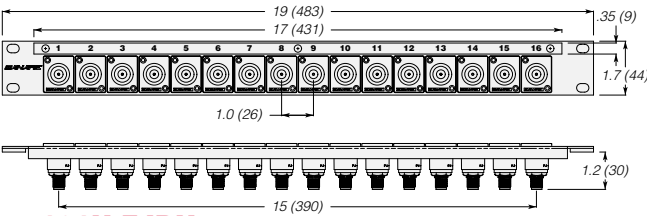

161U-FJRU

16ea 75Ω F-F Jacks

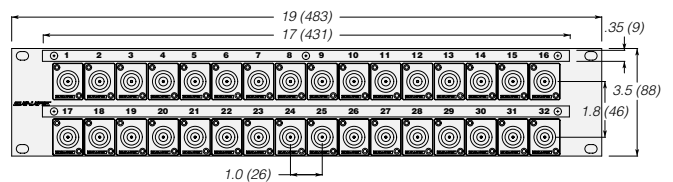

322U-FJRU

32ea 75Ω F-F Jacks

RCA • FLUSH MOUNT

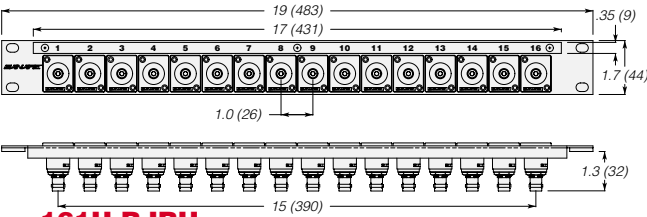

161U-RJRU

16ea 75Ω Type RCA-BNC Jacks

Insulator Colors: Red, Green, Blue, Yellow, White

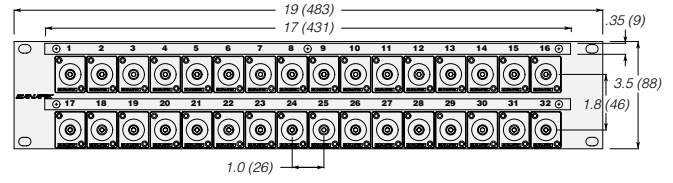

322U-RJRU

32ea 75Ω Type RCA-BNC Jacks

Insulator Colors: Red, Green, Blue, Yellow, White

XLR • FLUSH MOUNT

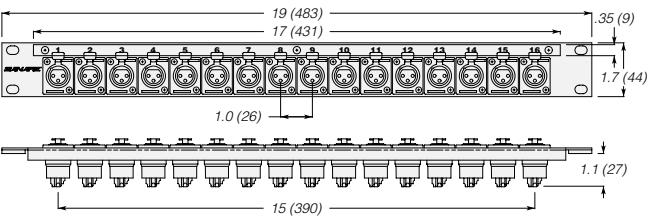

161U-X1F

16ea XLR3 Female-Solder Jacks

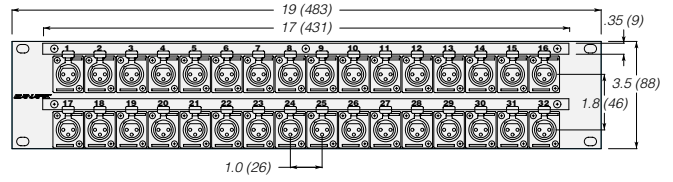

322U-X1F

32ea XLR3 Female-Solder Jacks

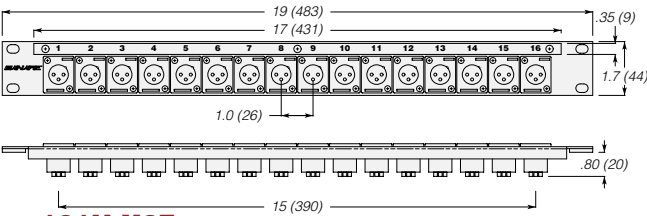

161U-X2F

16ea XLR3 Male-Solder Jacks

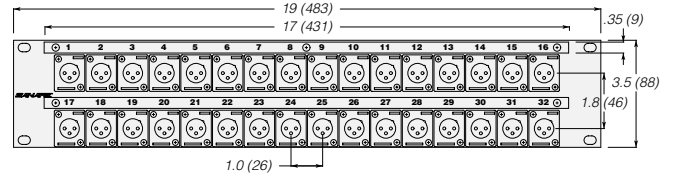

322U-X2F

32ea XLR3 Male-Solder Jacks

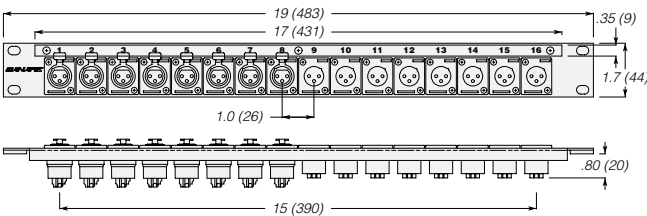

161U-X12F

8ea XLR3 Male & Female-Solder Jacks

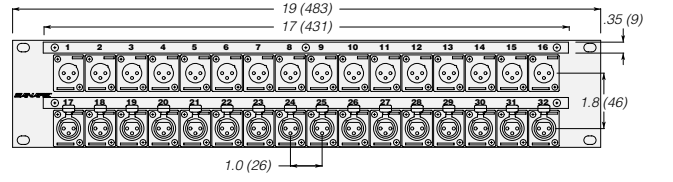

322U-X12F

16ea XLR3 Male & Female-Solder Jacks

APPLICATIONS

- SMPTE 259M & 292M COMPLIANT
- SERIAL DIGITAL VIDEO (SDI)
- HDTV UPGRADES (DTV)
- NTSC ANALOG
- TEST EQUIPMENT
- SATELLITE HEADENDS
- TELCOM

Features

- True 75Ω construction; Crimp Pin & Sleeve**
- DC to 2 GHz; ≥26 dB Return Loss (≤1.1 VSWR)**
- Mechanically mates with common 50Ω BNC**
- Elongated Body for better finger grip**
- Superior cable pull strength**
- Gold Plated Contact Pin 'Snap Locks' into place**
- Beryllium Copper Outer Contact**

Canare offers a full line of high performance **MIL-C-39012** true 75Ω BNC connectors with impedance matched performance characteristics and specifications that properly address the latest generations of high bandwidth digital video equipment.

Importantly, Canare 75Ω BNC connectors offer excellent mechanical pull strength and very low digital signal reflections; RL ≥26dB (VSWR ≤1.1) DC to 2GHz.

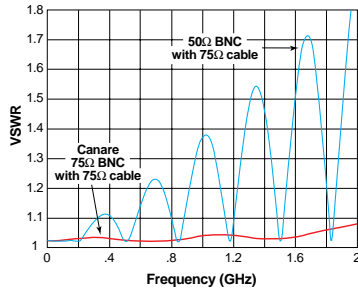

Influence by impedance matching and mismatching.

Note: Much of the 75Ω video coax cable in use today may still be terminated with 50Ω BNC connectors. Although this pairing is adequate for lower frequency bandwidths (such as standard NTSC broadcast transmissions), this mismatch will result in signal degradation and reduced picture quality at today's ultra high analog and digital video transmission rates.

Note:

We conveniently package our BNC crimp plugs in a special 100pc Egg-Carton style box. The Crimp Pins and Sleeves are supplied in 100pc Bulk Bags for quick and easy setup and assembly.

PTFE dielectric is designed with an exclusive **air gap** compensation circuit that maintains a constant 75Ω matched impedance, even if variances in contact pin crimping occur.

Characteristics of alloys

	COMPRESSION LIMIT VALUE kb (kg f/mm ²)
BERYLLIUM COPPER	150
PHOSPHOR BRONZE	100
SPRING BRASS	50

Beryllium Copper outer contact is extremely resilient to constant flexing.

Exclusive **Elongated Body** design allows better finger grip action. Special Nickel Plated Bell Brass remains brilliant even after many years of field service. Canare 75Ω BNC connectors will mechanically mate with all 50Ω type BNC connectors.

Canare Dual Crimp BNC connectors are a more reliable and rugged assembly than quick "twist-on" style BNC plugs.

Captive Contact Pin

Canare BNC crimp pins snap and lock into place to prevent pin migration, the leading cause of most BNC connector failure.

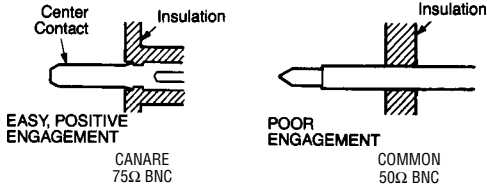

Gold plated center crimp pin inhibits corrosion and offers low contact resistance with superior mating properties.

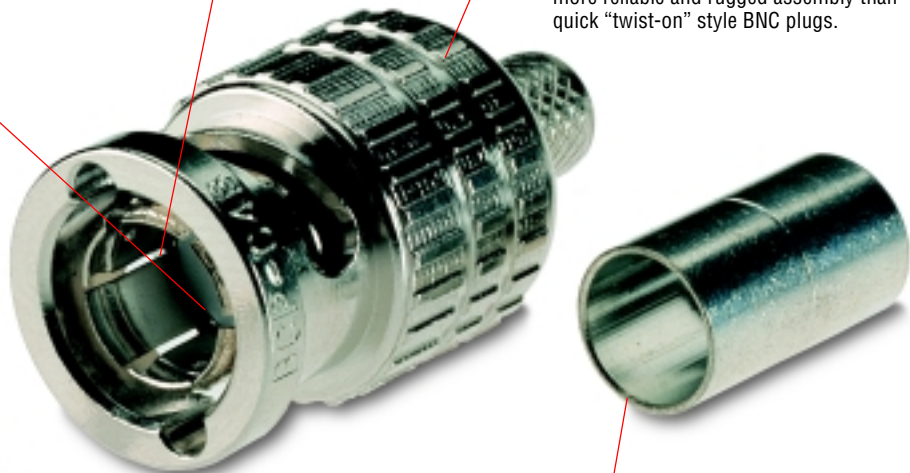

Our longer Sleeves offer a wider crimping surface area for improved cable pull strength.



The connector on the left is a commonly used 50Ω BNC. Notice that the dielectric (white ring) is visible at the top of the outer contact. The Canare plug on the right is a true 75Ω BNC connector. Its dielectric material is recessed... Your visual assurance that there will be proper 75Ω impedance matching between the source equipment, interconnecting cables, patchbay and load equipment. The end result: no signal reflections (VSWR) for longer cable runs and enhanced system performance.

Features

- True 75Ω construction; Crimp Pin & Sleeve
- DC to 2 GHz; ≥26 dB Return Loss (≤1.1 VSWR)
- Mechanically mates with common 50Ω BNC
- Elongated Body for better finger grip
- Superior cable pull strength
- Gold Plated Contact Pin 'Snap Locks' into place
- Beryllium Copper Outer Contact
- Easy Assembly using Canare Strip & Crimp Tools

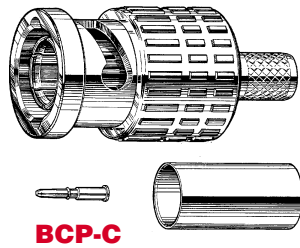

BCP-C

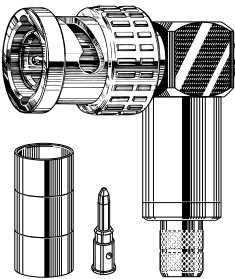
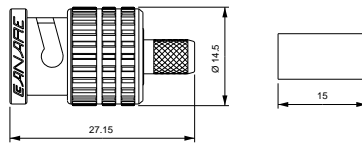

BCP-LC

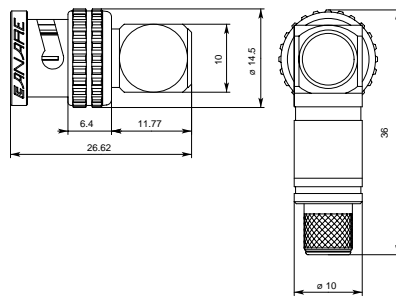

MODEL	PINS	SLEEVES
BCP-C1	(SOLDER)	BN7022
BCP-C25F	BN1051	BN7029B
BCP-C3B	B11014D	BN7003A
BCP-C3F	B11015D	BN7003A
BCP-LC3F	B11015D	BN7003A
BCP-C32	B11016D	BN7026
BCP-C4B	B11015D	BN7015A
BCP-C4F	B11016D	BN7015A
BCP-C41	B11016D	BN7016
BCP-C5B	B11016D	BN7016
BCP-C51	B11016D	BN7002
BCP-C53A	B11020C	BN7046
BCP-C55A	B11020C	BN7045
BCP-C5FA	B11020C	B75004
BCP-LC5F	B11020C	B75004
BCP-C77A	B11016D	B75004
BCP-C7FA	BN1012A	BN7021A
BCP-C71A	BN1043	BN7021A

Type 3 piece Assembly	Imp	Bandwidth VSWR Return Loss DC to 2GHz	Body Material Plating	Center Contact Material Plating	Dielectric	Crimp Sleeve Material Plating	Cable Retention lbs. (kgs)	Insulation resistance at 500V DC	Voltage rating for 1 minute	Center contact resistance	Outer contact resistance
Body Crimp Pin Crimp Sleeve	75Ω	≤1.1 ≥26 dB	Brass Nickel	Brass Gold	PTFE	Copper Tin	> 55 > 24.9	> 1000MΩ	1500V AC(rms)	< 6mΩ	< 3mΩ

CANARE 75Ω BNC CRIMP PLUGS **CABLE / CONNECTOR / TOOLING X-REFERENCE CHART**

BCP-C1	BCP-C25F	BCP-C3B	BCP-C3F BCP-LC3F	BCP-C32	BCP-C4B	BCP-C4F	BCP-C41	BCP-C5B	BCP-C51	BCP-C53A	BCP-C55A	BCP-C5FA BCP-LC5F	BCP-C77A	BCP-C7FA	BCP-C71A
--------	----------	---------	---------------------	---------	---------	---------	---------	---------	---------	----------	----------	----------------------	----------	----------	----------

CANARE CABLE															
L-1.5C2VS V-1.5C	L-2.5CFB	A2V1 A2V2-L V-3C	L-3C2VS	V-3CFB A3V1-FB A3V2-FB	L-3CFB	LV-61S	V-4CFB	L-4CFB	V-5C	L-5CFB V-5CFB	LV-77S	L-7CFB			

BELDEN															
83264 83267	1855A					1506A 1824A 1825A 1826A	8241 8279 (RC59B/U)	1505A 8241F 8212 9167 9259 9659		8281 88281 728A 8281B	1694A 9066 9116 89120 633948 9116P	1695A 87120 89120	9290 1189A	8281F	9011 9064 9292 87292 89292 1617A 7731A

COMMSCOPE															
	7538 753605					2037V 2041K 2065V		2000 5553 5565 5572 556510	S59HEC2	7501 7506	2227K/V 2229V 5729 2277V F690BVV	2275V 2276V 2277V 2279V	5731		5906 5940 2285K 5914 F115SVV

COAX CABLE STRIPPERS	N/A	TS100E	TS100E TS-V3C	TS100E TS-3C	TS100E TS-V3C	TS100E TS-3C	TS100E TS-3C	TS100E TS-3C	TS100E TS-4C	TS100E TS-3C	TS100E TS-4C	TS100E	TS100E TS-4C	TS100E TS-5C	TS100E	TS100E TS-5C	TS100E TS-5C	TS100E	TS100E
TOOL TC-1	○	○	○	○	○	○	○	○	○	○	○	○	○	○	○	○	○	○	○
DIE SETS TCD-1DB	●																		
TCD-3C		●	●	●	●	●	●	●											
TCD-35CA		●	●	●	●	●	●	●											
TCD-4C									●	●	●								
TCD-451CA									●	●	●								
TCD-5CF															●	●			
TCD-7CA																		●	●

● Alternate Die Set.
Note: All Stripper Models are Pre-Set for Canare 75Ω BNC Crimp Plug Dimensions

BCJ-JRU

75Ω BNC RECESSED Bulkhead
 Jack to Jack
 Mounts in Common Canare Hole Punch
 Totally Isolated from Panel
 ≤1.1 VSWR DC-2GHz

BCJ-RU

75Ω BNC RECESSED Bulkhead
 Jack to Solder Pin
 Mounts in Common Canare Hole Punch
 Totally Isolated from Panel
 ≤1.1 VSWR DC-2GHz

BCJ-JR

75Ω BNC Bulkhead
 Jack to Jack
 Use with Isolation Bushing IU-7/16
 Double D Hole Punch
 ≤1.1 VSWR DC-2GHz

BCJ-R/1

75Ω BNC Bulkhead
 Jack to Solder Pin
 Use with Isolation Bushing IU-7/16
 Double D Hole Punch
 ≤1.1 VSWR DC-2GHz

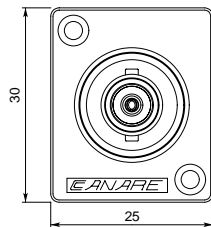
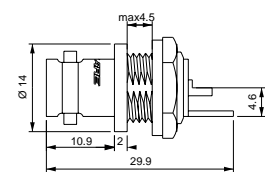
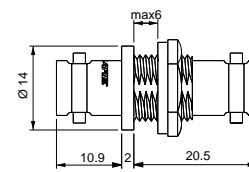
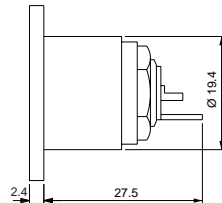
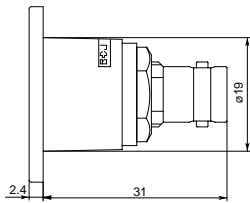
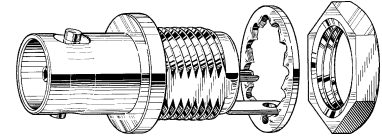
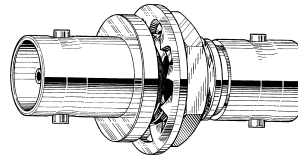
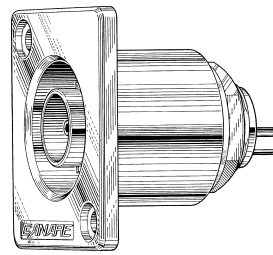
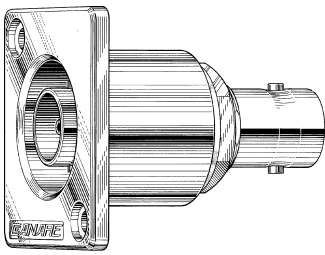

Front View

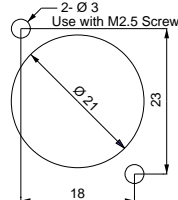

Canare Recessed Panel Mount Hole Dimensions

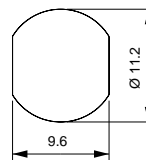

Double D Panel Mount Hole Dimensions (without IU-7/16 Iso Bushing)

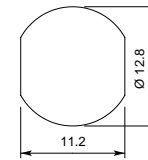

Double D Panel Mount Hole Dimensions (with IU-7/16 Iso Bushing)

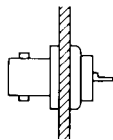

Because ordinary panel mount BNC bulkhead connectors are often precariously exposed on a wall plate located in high traffic areas, they offer little protection from physical damage.

To solve this problem, Canare developed a unique recessed **flush mount** panel jack design that effectively protects the housed connector.

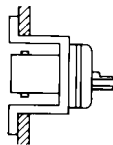

Our BCJ-JRU and BCJ-RU BNC jacks have a **built in panel isolation bushing**, so they may safely reside on the panel alongside any audio, power, data or intercom lines without electrical crosstalk or grounding problems. Also available in recessed 75Ω **F** and **RCA** jack versions.

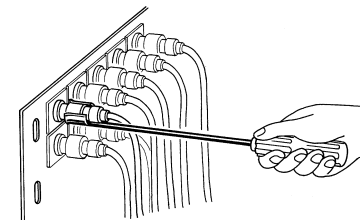

Canare now offers a high quality removal tool (**BET-12**) that can be used to insert & extract all Canare BNC crimp plugs from our recessed or standoff BNC receptacles and DVJ digital video jacks.

Note: any generic 50Ω BNC plug will mechanically mate with Canare 75Ω BNC fittings.



BCJ-JRU



BCJ-RU



BCJ-JR



BCJ-R/1

75Ω BNC JACK NOMINAL SPECIFICATIONS

Bandwidth VSWR Return Loss DC to 2GHz	Center Contact Material Plating	Body Material Plating	Dielectric	Flange Material Plating	Insulation resistance at 500V DC	Voltage rating for 1 minute	Center contact resistance	Outer contact resistance
≤ 1.1 > 26dB	Beryllium Copper Gold	Brass Nickel	PTFE	DieCast AL Nickel	> 1000MΩ	1500V AC(rms)	< 6mΩ	< 3mΩ

BCP-TA FEATURES

- DC to 2 GHz; ≥26 dB Return Loss (≤1.1 VSWR)**
- 75Ω Metal Film Resistor (± 1%, 1/4 Watt @°100ppm)**
- Gold Plated Center Pin; Beryllium Copper Outer Contact**
- Specially Designed for all Digital Video Equipment**
- Elongated Body Design**

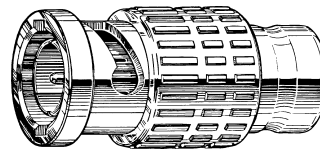

BCP-TA

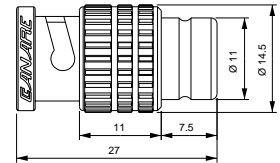

All 75Ω signals, once entered into a termination, must be fully converted into energy. If the impedance matching is not perfect, part of this energy will be reflected and poor Return Loss (VSWR) will result, especially at higher operating frequencies (i.e. computer graphics, digital video, etc.).

Common BNC terminators use a 50Ω type body with a generic 75Ω DC resistor tacked onto the back of the center contact pin.

Canare's precision 75Ω BCP-TA, far exceeds (by 20 to 30 dB) other commercial terminations, even those rated at .1% tolerance.

Careful attention to impedance design detail, makes this the first true 75Ω termination with the same VSWR performance found in test lab precision terminators which cost hundreds of dollars.

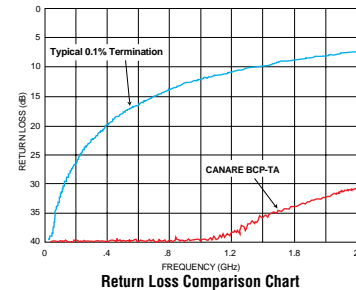

Return Loss Comparison Chart

ISOLATION BUSHINGS

IU-7/16

- 2 Piece Expandable Isolation Bushing
- Colors: Blk, Blu, Grn, Red, Wht, Yel
- High compression, ABS plastic
- Accommodates 1.2mm ~ 3mm thick panels

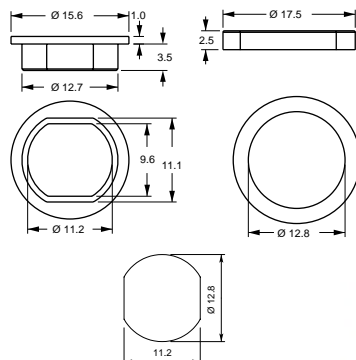

IU-7/16 Panel Mount Hole Dimensions



75Ω BNC BARREL

BCJ-J

- 75Ω BNC in-line cable extension adapter
- Jack to Jack
- ≤1.1 VSWR DC-2GHz

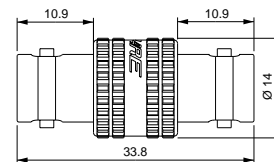
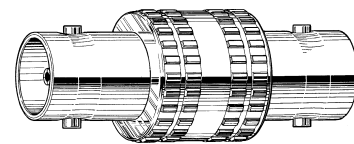

75Ω BNC PC MOUNT RECEPTACLES

APPLICATIONS

- OEM'S
- HDTV EQUIPMENT
- TELCO BROADBAND
- NTSC ANALOG VIDEO
- SATELLITE HEADEND

FEATURES

- ≥26 dB Return Loss; DC to 1GHz (≤VSWR 1.1)
- Securely mounts to PCB with Chassis Support
- Gold Plated Beryllium Copper center contact

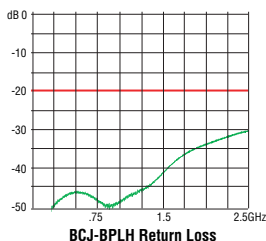

BCJ-BPLH Return Loss

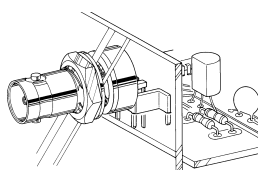

For complete model listings & detailed product specifications, request Canare's "OEM Parts Catalog"

BNC DUST CAP

BCJ-DC

- Protects all unused BNC Bulkhead Receptacles from dirt and dust

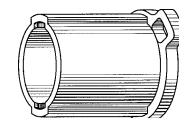

FJ-JRU

75Ω F RECESSED Bulkhead Port
 Jack (Female) to Jack (Female)
 Mounts in Common Canare Hole Punch
 Totally Isolated from Panel
 ≥26dB (≤1.1 VSWR) DC-2GHz

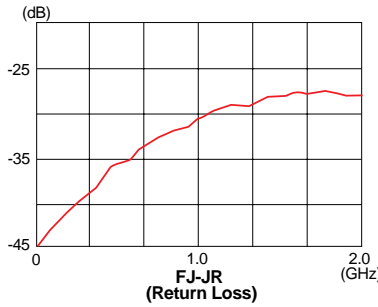
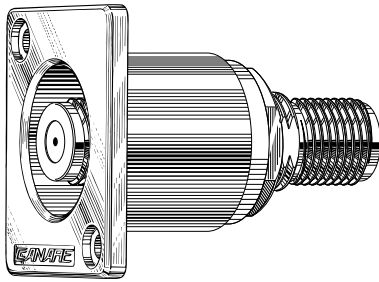

FJ-JR

75Ω F Bulkhead Port
 Jack (Female) to Jack (Female)
 Double D Hole Punch
 IU-7/16 Iso Bushing
 ≥26dB (≤1.1 VSWR) DC-2GHz

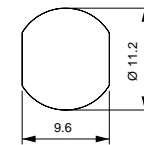
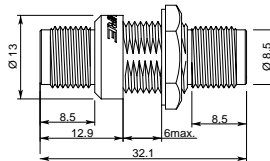
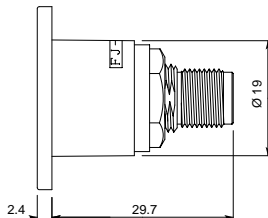
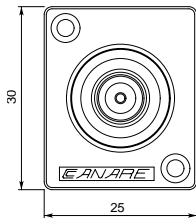
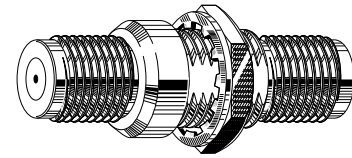

Double D
 Panel Mount Hole Dimensions
 (without IU-7/16 Iso Bushing)

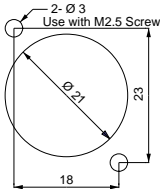

Canare Recessed
 Panel Mount Hole Dimensions

75Ω F JACK NOMINAL SPECIFICATIONS								
Bandwidth VSWR Return Loss DC to 2GHz	Center Contact Material Plating	Body Material Plating	Dielectric	Flange Material Plating	Insulation resistance at 500V DC	Voltage rating for 1 minute	Center contact resistance	Outer contact resistance
≤ 1.1 > 26dB	Beryllium Copper Gold	Brass Nickel	PTFE	DieCast AL Nickel	> 500MΩ	500V AC(rms)	< 5mΩ	< 5mΩ

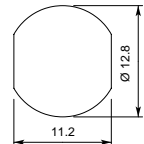

Double D
 Panel Mount Hole Dimensions
 (with IU-7/16 Iso Bushing)



FJ-JRU



FJ-JR

75Ω F PC MOUNT RECEPTACLE

APPLICATIONS

- OEM
- BROADBAND EQUIPMENT
- CABLE MODEMS
- RF BOXES
- SATELLITE SYSTEMS

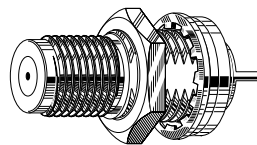

Canare introduces a new high precision 75Ω F Receptacle for PC Board solder trace hole mounting. This new connector is impedance matched and perfectly suited for use in all advanced generations of Digital Video Broadcast Equipment as well as other applications where high bandwidth and low Return Loss is required.

FEATURES

- ≥26 dB Return Loss (≤1.1 VSWR); DC to 2GHz
- Securely mounts to PCB with Chassis Support
- Gold Plated Beryllium Copper center contact

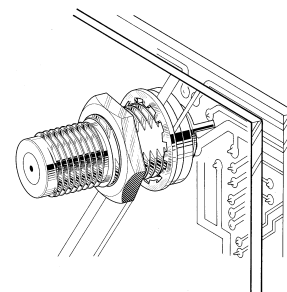

For complete model listings & detailed product specifications, request Canare's "OEM Parts Catalog"

APPLICATIONS

- DIGITAL BROADBAND
- SATELLITE SYSTEMS
- RF EQUIPMENT
- CABLE MODEMS
- HEADENDS

FEATURES

- **≥26dB Return Loss DC–2GHz (≤1.1 VSWR)**
- **Crimp Pin & Sleeve Design**
- **Use with Solid or Stranded Center 75Ω Coax**
- **Center Pin Snap Locks into Connector**
- **Superior cable pull strength**

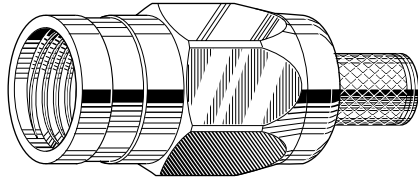

FP-C

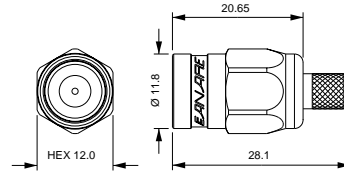
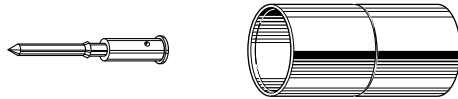

F MODEL	PINS	SLEEVES
FP-C3	BN1002A	BN7003A
FP-C3F	BN1003A	BN7003A
FP-C4	BN1003A	BN7015A
FP-C4F	BN1004A	BN7015A
FP-C5	BN1004A	BN7016
FP-C51	BN1004A	BN7002
FP-C53A	BN1005A	BN7046
FP-C55A	BN1005A	BN7045
FP-C5F	BN1005A	B75004
FP-C7FA	BN1030	BN7021A
FP-C71A	BN1041	BN7021A

Type	Imp (Ω)	Bandwidth VSWR Return Loss	Body Material Plating	Center Contact Material Plating	Dielectric	Crimp Sleeve Material Plating	Cable Retention lbs. (kgs)	Insulation resistance at 500V DC	Voltage rating for 1 minute	Center contact resistance	Outer contact resistance
Dual Crimp Pin & Sleeve	75	DC to 2GHz ≤ 1.1 > 26 dB	Brass Nickel	Brass Gold	PTFE	Copper Tin	> 55 > 24.9	> 500MΩ	500V AC(rms)	< 5mΩ	< 5mΩ



Most F connectors on the market utilize a coaxial cable's solid inner conductor as the plug's center contact pin. This design can cause near and long term problems from center conductor nicks, bending, dielectric migration, metal fatigue and contact corrosion. Furthermore, this type of commonly installed F connector may also produce signal degradation, outages, poor picture quality, RF leakage problems and most importantly... *an expensive service call.*

To meet the growing demands of advanced Digital Broadband equipment, Canare has developed the world's first precision, high reliability 75Ω F Connector. Electromechanically stable (nickel over brass body, high quality tapped threads, extra wide torque nut, gold crimp pin, extra long crimp sleeve), our FP-C is quick to install using the same Canare strip & crimp tools as our standard 75Ω BNC and RCA plugs.

Canare true 75Ω F Connectors are impedance matched with excellent Return Loss characteristics and can easily handle future "Smart House" RF broadband multimedia networks to 1 GHz and beyond. Will mate with **SCTE** approved standard F receptacles.

75Ω F Crimp Plugs		CABLE / CONNECTOR / TOOLING X-Reference Chart												
		FP-C3	FP-C3F	FP-C4	FP-C4F	FP-C5	FP-C51	FP-C53A	FP-C55A	FP-C5F	FP-C7FA	FP-C71A		
CANARE CABLE														
		A2V1 A2V2-L V-3C	L-3C2VS	L-3CFB	A3V1-FB A3V2-FB V-3CFB	LV-61S	L-4CFB	V-4CFB	V-5C				L-5CFB V-5CFB	L-7CFB
BELDEN														
					8241 8279 88241	1505A 8241F 8212 9167 9259 9659	1506A			8281 88281 728A 8281B	1694A 9066 9114 89120 9116 9118 9248	1695A 87120 89120 633948 9116P	9290 1189A	1617A 7731A 9011 9054 9252 87292 89292
COMMSCOPE														
						2000 5553 5565 5572 556510	2065V		7501 7506	2227K/V 2229V 5729 5768 F690BVV	2275V 2276V 2277V 2279V	5731		5906 5940 2285K 5914 F115SVV
COAX CABLE STRIPPERS		TS100E TS-V3C	TS100E TS-3C	TS100E TS-3C	TS100E TS-V3C	TS100E TS-4C	TS100E TS-4C	TS100E TS-3C	TS100E TS-4C	TS100E TS-5C	TS100E TS-31C	TS100E	TS100E TS-5C	TS100E
TOOL	TC-1	○	○	○	○	○	○	○	○	○	○	○	○	○
DIE SETS	TCD-3C	●	●	●	●									
	TCD-35CA	●	●	●	●									
	TCD-4C					●	●	●						
	TCD-451CA					●	●	●						
	TCD-5CF												●	
	TCD-7CA													●

● Alternate Die Set.
Note: All Stripper Models are Pre-Set for Canare 75Ω F Crimp Plug Dimensions

RJ-BCJRU

75Ω Type RCA to BNC RECESSED Bulkhead
Jack (Female) to Jack (Female)
Mounts in Common Canare Hole Punch
Totally Isolated from Panel
≤1.1 VSWR DC-100MHz

RJ-RU

75Ω Type RCA RECESSED Bulkhead
Jack (Female) to Solder Cup
Mounts in Common Canare Hole Punch
Totally Isolated from Panel
≤1.1 VSWR DC-100MHz

RJ-BCJR

75Ω Type RCA to BNC Bulkhead
Jack (Female) to Jack (Female)
Use with Isolation Bushing IU-7/16
Double D Hole Punch
≤1.1 VSWR DC-100MHz

RJ-R

75Ω Type RCA Bulkhead
Jack (Female) to Solder Cup
Use with Isolation Bushing IU-7/16
Double D Hole Punch
≤1.1 VSWR DC-100MHz

Insulator Colors: Red, Green, Blue, Yellow, White

Insulator Colors: Red, Yellow, White

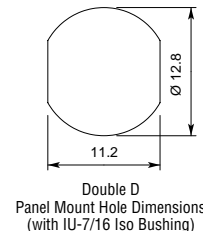
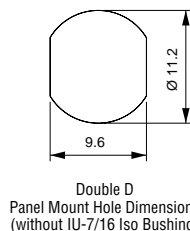
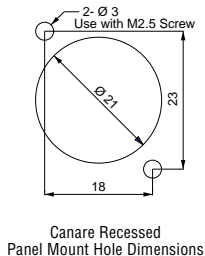
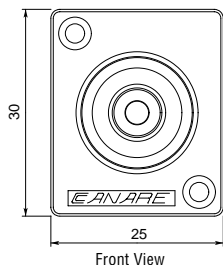
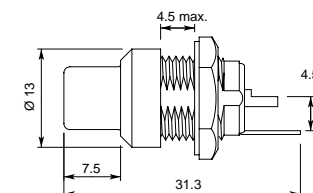
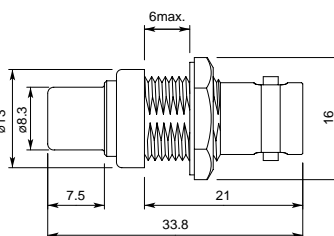
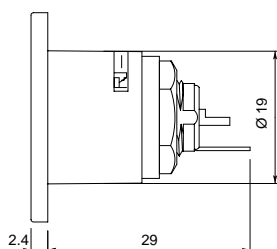
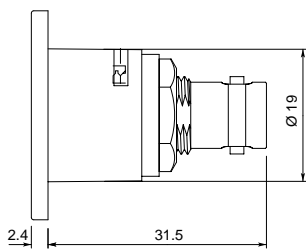
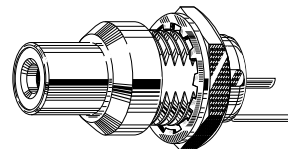
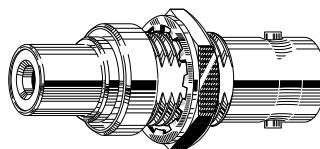
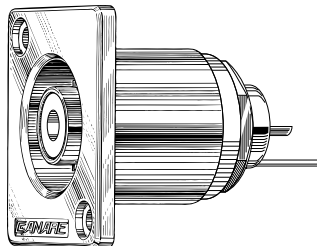
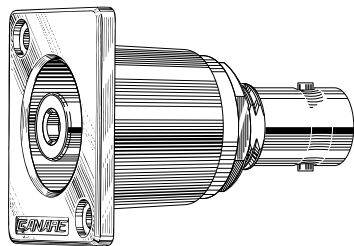

75Ω TYPE RCA JACK SPECIFICATIONS							
Bandwidth VSWR Return Loss DC to 100MHz	Center Contact Material Plating	Body Material	Dielectric	Flange Material Plating	Insulation resistance at 500V DC	Voltage rating for 1 minute	Center contact resistance
≤ 1.1 > 26dB	Beryllium Copper Gold	Brass Nickel	PTFE	DieCast AL Nickel	> 100MΩ	500V AC(rms)	< 10mΩ

APPLICATIONS

- MULTIMEDIA PATCHCORDS
- HI-RES VIDEO MONITORS
- SPDIF DIGITAL AUDIO
- DUPLICATION DECKS
- VCR & CAMCORDERS
- AUDIO INTERCONNECTS

FEATURES

- VSWR ≤1.1 DC to 200MHz**
- Absolutely No Soldering Required**
- Assembly Time Reduced by >80%**
- Use Standard Canare Crimp & Strip Tools**
- Internal Pressure Contact Fingers**
- Gold Plated Center Shaft**
- Wide Selection of Cable Types**

MODEL	PINS	SLEEVES
RCAP-C3A	B11014D	BN7003A
RCAP-C3F	B11015D	BN7003A
RCAP-C4A	B11015D	BN7015A
RCAP-C4F	B11016D	BN7015A
RCAP-C5A	B11016D	BN7016
RCAP-C53	B11020C	BN7016
RCAP-C5F	B11020C	B75004
RCAP-C77	B11016D	B75004

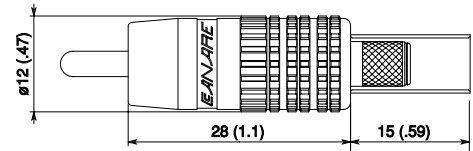
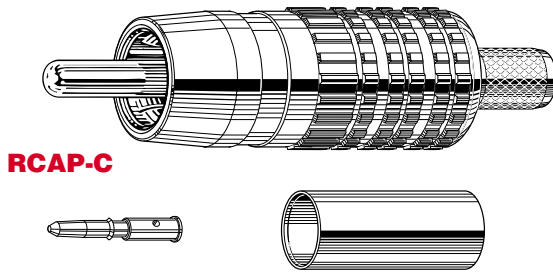

75Ω TYPE RCA CRIMP PLUG NOMINAL SPECIFICATIONS											
3-Piece Assembly	Bandwidth VSWR Return Loss	Body Material Plating	Center Contact Material Plating	Outer Contact Material Plating	Dielectric	Crimp Pin Material Plating	Crimp Sleeve Material Plating	Cable Retention lbs.(kgs)	Insulation resistance at 500V DC	Voltage rating for 1 minute	Contact resistance
Body Crimp Pin Crimp Sleeve	DC to 200MHz ≤ 1.1 > 26 dB	Brass Nickel	Phosphor Bronze Gold	Beryllium Copper Gold	PPO Noryl	Brass Gold	Copper Tin	> 55 > 24.9	> 100MΩ	500V AC(rms)	< 10mΩ

Generic “off-the-shelf” RCA audio plugs are quite common and have been in use for a very long time...well over 50 years! These old-style RCA type solder plugs have an impedance characteristic of roughly 25Ω and exhibit extremely poor Return Loss performance when mated with precision 75Ω coaxial video cable. In fact, they are virtually unusable for 6MHz Broadcast Video frequencies, high bandwidth RGB Video Monitor lines, or even Digital Audio data bit streams.

Canare’s all new 75Ω type RCAP Video Crimp Plugs are impedance matched and achieve outstanding analog and digital electrical performance with a usable bandwidth to 200MHz.

Our original 3-piece connector design offers consistent and extremely reliable terminations with a wide variety of 75Ω coaxial cable sizes. This unique construction reduces set-up and assembly time by >80% because no soldering is ever required!

Assembling your own high-quality Canare RCA video patch cords is now quick, easy and affordable...you just: (a) strip back the cable, (b) crimp on the center pin, (c) snap-lock the pin with cable into the RCAP body, (d) slide up the sleeve and crimp...that’s all there is to it!

All RCAP connectors utilize the same high-quality gold Pins & Sleeves found in Canare’s most popular 75Ω BNC crimp plug series. This special design feature permits 100% compatibility with the standard Canare Hand Tool, Die sets and our award winning “15 Second Quick” TS coaxial cable Strippers.



75Ω TYPE RCA CRIMP PLUG		CABLE / CONNECTORS / TOOLING X-Reference Chart									
		RCAP-C3A	RCAP-C3F	RCAP-C4A	RCAP-C4F	RCAP-C5A	RCAP-C53	RCAP-C5F	RCAP-C77		
CANARE CABLE											
		A2V1 A2V2-L V-3C	L-3C2VS	L-3CFB	A3V1-FB A3V2-FB V-3CFB	LV-61S	L-4CFB	V-4CFB	V-5C	L-5CFB V-5CFB	LV-77S
BELDEN											
					8241 8279	1505A 8212 8241F 9167 9259 9659	1506A		1694A 9116 9066	1189A 9290	8281F
COMMSCOPE											
						2000 5553 5565 5572 556510			2227K/V 2229V	5731	
COAX CABLE STRIPPERS		TS100E TS-V3C	TS100E TS-3C	TS100E TS-3C	TS100E TS-V3C	TS100E TS-4C	TS100E TS-4C	TS100E TS-3C	TS100E TS-4C	TS100E TS-31C	TS100E TS-5C
TOOL	TC-1	○	○	○	○	○	○	○	○	○	○
DIE SETS	TCD-3C	●	●	●	●						
	TCD-35CA	●	●	●	●			●	●		
	TCD-4C				●	●	●				
	TCD-451CA				●	●	●				
	TCD-5CF									●	●

● Alternate Die Set.
Note: All Stripper Models are Pre-Set for Canare 75Ω Type RCA Crimp Plug Dimensions



A consistent and reliable crimp connection is the direct result of a Quality Controlled Termination Set consisting of: The *Coaxial Cable, Connector, Stripper, Crimp Tool and precision Die Set*. Canare offers a complete turnkey Assembly Package. There is no tooling guesswork...the only surprise is how quick and easy it is to terminate your own cables.



R5A Storage Road Case

- Low cost, lightweight yet rugged, holds:
- (1-2) **TC-1** hand tools
- (5) **TCD** crimp die sets
- (100) Canare **BNC, F or RCA** crimp plugs
- (1) **TS100E** or, (3) **TS-C** Stripping tools
- Misc. adapters, replacement blades, rulers, etc.

TC-1 Hand Crimp Tool

- Interchangeable die sets
- Scissor ratchet action
- Emergency release lever
- Adjustable crimp force via drag washer
- Hardened Swedish Steel construction
- Rated at 50,000 dura-cycle lifespan

TCD Die Sets

- 2 piece precision fit design
- 2 Hex Bolts for quick hand tool loading
- Tight dimensional tolerances
- 1 and 2 Hex Sleeve versions
- Engraved Model I.D.

Buyer Beware:

There are other products available that may look similar to the Canare TC-1 Hand Crimp Tool & TCD Die Sets, but they may not meet the same high quality standard and will not perform to our strict specifications.

TS-SERIES COAXIAL CABLE STRIPPERS

Stripping & prepping coaxial cable for Canare's true 75Ω BNC, F and RCA Crimp Connectors, is now simple, quick and easy. No more hassles working with awkward razor blades or difficult-to-use straight edge tools. Our TS-Series dramatically reduces assembly time when compared to most other commonly used methods. You simply "insert the cable, rotate and remove". Completes the job in just 15

seconds! All models have 3 fully-adjustable circular steel blades, specially designed and hardened to precisely cut "around" the cable...not chop through it like utility knives or ordinary wire strippers. Our innovative side-slit blade allows you to carefully peel off the jacket for constant and productive cable prep.



TS100E



TS-4C

TS-C Coaxial Cable Strippers

- 3 Circular Steel Cutting Blades
- 'Side Slit Blade' for easy peel jacket
- Blade height fully adjustable



TS-3C

TS-5C



TS-V3C

NEW!

TS100E "5 in 1" Coaxial Cable Stripper

- Quick & Easy-to-use hand tool
- Rotary Knob selects 5 different cable set-ups
- 3 Circular Steel Blades Cut clean & precise
- Blade height is fully adjustable, wrench included
- Special extra "side-slit" jacket blade
- Unique V-Guide aligns coax in center of chamber
- 5 Factory pre-sets...or, create your own settings

TSC Blade Cassette

- Replaceable circular steel blade pack

MODEL SELECTION	
Model	Max. Cable O.D.
TS100E	.158in - .433in (4mm - 11mm)
TS-V3C	.197in (5.0mm)
TS-3C	.236in (6.0mm)
TS-4C	.256in (6.5mm)
TS-31C	.291in (7.4mm)
TS-5C	.327in (8.3mm)

Strip Lengths all Models (mm)

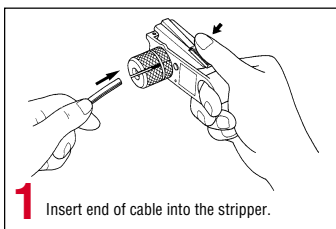
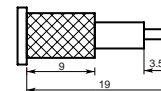

1 Insert end of cable into the stripper.

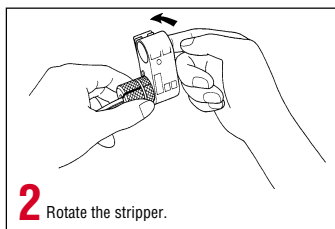

2 Rotate the stripper.

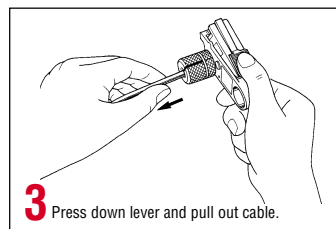

3 Press down lever and pull out cable.

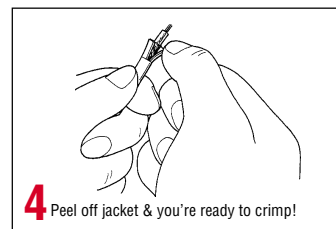

4 Peel off jacket & you're ready to crimp!

Application note: All stripper models are pre-set for use with Canare BNC, F and RCA Crimp Plug dimensions only.

CANARE CABLE REEL STAND



CRS-02 Cable Storage Rack

Canare introduces a premium cable reel storage rack stand that easily accommodates 10 full-size Canare Cable spools (ex: 10ea. 300 meter rolls of L-5CFB). Extra heavy duty gauge steel frame with solid reinforced welded joints. Rugged crinkled powder coat Blue finish.

Includes four (4) industrial strength roll-around locking casters so rack 'stays put' when paying out cable.

A must-have for multiple cable pulls, system installation job sites and professional wire assembly shops.

BNC EXTRACTION TOOL

**BET-12
BET-08**

Our specially designed connector removal tool perfectly fits not only Canare 75Ω BCP-C BNC series, but all other standard MIL-SPEC BNC line plugs. The BET-12 allows easy access to those hard-to-reach BNC jacks located deep inside rear rack enclosures.

Tapered channel socket permits various cable O.D. sizes up to and including Canare L-7CFB, RG11 (.405in, 10.29mm). Long 12 inch heavy duty metal probe shaft will not bend or deform under normal use. Clear Blue plastic handle.



ASSEMBLY • CANARE 75Ω BNC, F AND RCA CRIMP PLUGS

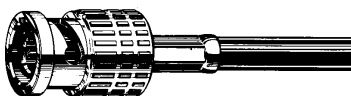
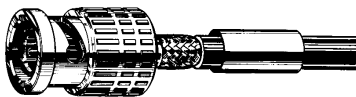
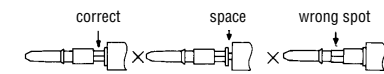
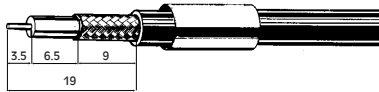
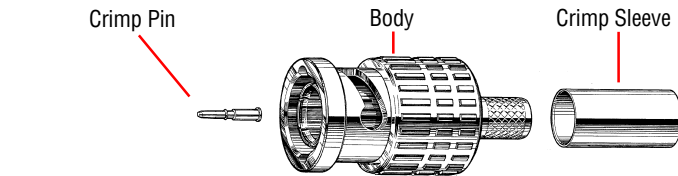

1. Slide crimp sleeve over cable.
2. Strip cable jacket using Canare TS-Series Coax Strippers (see mm dimensions)
3. Place contact pin on center conductor. Using the TC-1 hand tool and appropriate die set, crimp center pin as shown in diagram. (Do not leave a gap between rear of the pin and cable insulation end.)
4. Flair braided shield to aid insertion of connector body.
5. Push cable with crimped pin into body housing until you detect an audible "snap". (Jamming the pin may bend center conductor and damage connector dielectric.)
6. Lightly tug cable (@ 4.5 lbs/2.0 kgs) to verify that pin is properly seated in body housing.
7. Slide crimp sleeve up against the body and place in tool die.
8. Complete assembly by crimping down on sleeve to form hex.

Note: Flair gap at sleeve end is normal and allows cable jacket extra flexing room.

CABLE BOOT

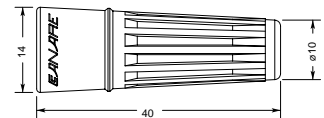
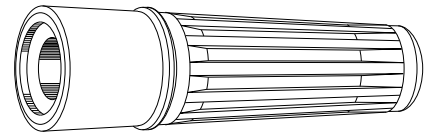

CB04

Our new push-on silicon rubber boot helps prevent cable damage at the connector sleeve stress point due to flexing, fatigue and environmental changes. Available in 10 matte colors for matching cable jacket or channel ID call-outs.

MODEL SELECTION	
Model	Fits on Cable
CB03	L-3C2VS, L-3CFB, V-3C, V-3CFB
CB04	LV-61S, L-4CFB, V-4CFB
CB05A	LV-77S, L-5CFB, V-5C, V-5CFB

BOOT COLORS AVAILABLE									
BLK	BLU	BRN	GRY	GRN	ORN	PPL	RED	WHT	YEL

APPLICATIONS

- GUITAR / KEYBOARDS
- SOUND MIXERS
- PA SYSTEMS
- TEST PROBES
- HI-FI INTERCONNECTS

Canare offers in-line cable mount audio plugs in a variety of configurations for the discriminating professional. Each model is carefully designed to accommodate small to large O.D. cables and all versions offer a generous soldering area for easy wiring assembly, good electromechanical characteristics, super performance and long life durability.

FEATURES

- Robust Dependable Construction**
- Brass with Nickel/Gold Plating**
- 360° Crimpable Cable Strain Relief**
- Easy to Solder**
- Beautiful Long Lasting Finish**

F-09 and F-10 plugs have a Gold plated brass inner shaft that offers low contact resistance and eliminates corrosion problems with the mating receptacle.

Canare F-Series audio plugs feature a proprietary 360° cable clamp design that ensures long life reliability.

All F-Series audio plugs have a beautiful nickel plated, bell brass handle with a specially designed knurled surface to prevent finger slippage.

The F-09 RCA plug features an extra narrow profile body (for high density panels). The handle extends over the outer contact sleeve for improved RF shielding.

Spring type strain relief prevents cable damage due to repeated bending at the connector entry point; cable lasts three times longer than plugs without strain relief.



F-10

Reinforced one-piece body and sleeve includes a pure brass bar that runs the length of the handle; 50% stronger than ordinary plugs and 20% stronger than other high-grade plugs.



F-15

Satin-finished, nickel-plated solid brass handle, shuts out static and electromagnetic noise.

Canare F-15 and F-16 1/4" phone plugs use a patented "V-Lock" system that ensures good electrical contact by keeping the plugs tight where others pull out.



F-09



F-11



F-16



F-12

CONNECTOR SPECIFICATIONS									
Model	Type	Notes	Cable Entry I.D. in (mm)	* Max Cable O.D. in (mm)	Shaft material plating	Dielectric	Body material plating	Insulation tube	Cable spring plating
F-09	RCA	Narrow profile. Body extends over contact	.248 6.3	.236 6.0	Brass Gold	Polyacetal	Brass Nickel	-	Nickel
F-10	RCA	Deluxe clamp and body design	.244 6.2			PTFE		Black PVC	
F-11	Mini Phone TS	Tip, Sleeve	6.2		Gold Nickel	-		-	
F-12	Mini Phone RTS	Ring, Tip, Sleeve	.248 6.3					Black PVC	
F-15	1/4" TS phone	Tip, Sleeve	.244						
F-16	1/4" RTS phone	Ring, Tip, Sleeve	6.2						

* With Spring Removed, Max. Cable O.D. is .295in (7.5mm)

APPLICATIONS

- POST PRODUCTION SUITES
- DAT ROUTING
- RECORDING STUDIOS
- DIGITAL AUDIO TIE LINES

FEATURES

- SMPT E 276M & AES3 Transmission Standards**
- Coaxial Routing of 2 Channel AES/EBU Digital Audio**
- Permits longer cable runs vs 110Ω Twisted Pair**
- Signal Distribution: Canare Video Patchbays, Routers & VDA's**

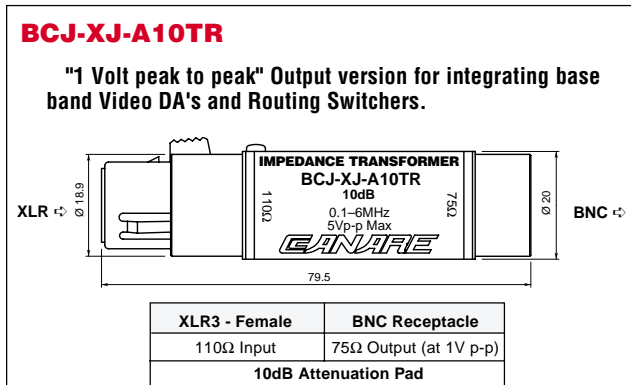
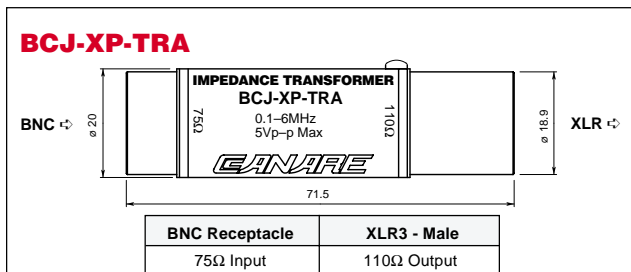
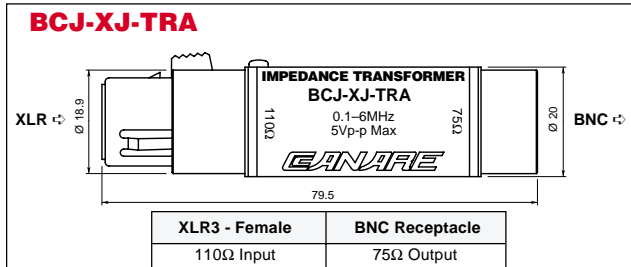

GENERAL SPECIFICATIONS

Bandwidth: 0.1 ~ 6MHz
Maximum Voltage: 5V p-p
VSWR: Less than 1.1
Insertion Loss: Less than 0.3 dB

Canare Impedance Transformers allow 75Ω coaxial transmission of all 2 channel AES/EBU Digital Audio signals. Low cost and easy to use, our I/O adapters are designed to passively convert all standard AES/EBU digital audio signals from 110Ω/XLR3 Output (@ 4.5 Volts) to a 75Ω BNC coaxial cable and then back again to a 110Ω/XLR3 Input (200mV min). Also provides excellent rejection against hum and noise.

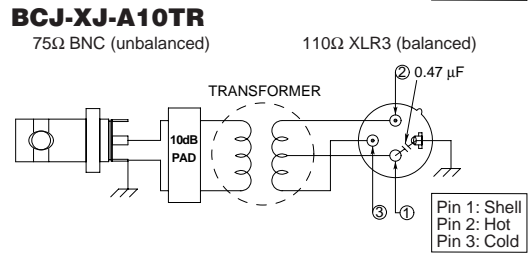
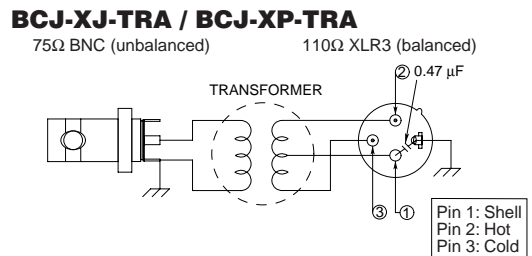

NEW!

PANEL MOUNT VERSIONS

Fits in all standard Canare Bulkhead Panels (pages 8~9)

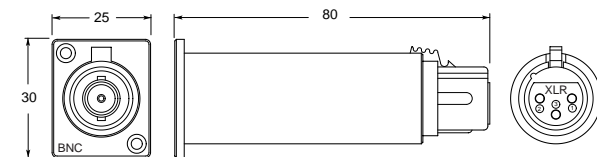

Model	Description (Front ~ Back)
XJ3F-TRA-BCJ	XLR(F) ~ BNC
XJ3M-TRA-BCJ	XLR(M) ~ BNC
BCJ-TRA-XP3F	BNC ~ XLR(F)
BCJ-TRA-XP3M	BNC ~ XLR(M)
XJ3F-A10TR-BCJ	XLR(F) ~ BNC 10dB Pad
BCJ-A10TR-XP3F	BNC ~ XLR(F) 10dB Pad

110Ω - 75Ω Impedance Transformer: Input/Output Level Performance

AES/EBU Transmitter (V)	Transformer Out (V)	AES/EBU Transmitter (V)	Transformer Out -10dB Pad (V)
2.0	1.60	2.0	0.50
3.0	2.39	3.0	0.75
4.0	3.18	4.0	1.01
4.5	3.60	4.5	1.13
5.0	3.98	5.0	1.26
6.0	4.78	6.0	1.51
7.0	5.58	7.0	1.76
8.0	6.38	8.0	2.02
9.0	7.18	9.0	2.27
10.0	7.98	10.0	2.52

BCJ-XJ-TRA / BCJ-XP-TRA

BCJ-XJ-A10TR

APPLICATIONS

- SERIAL DIGITAL VIDEO (SDI)
- SATELLITE HEAD ENDS
- HDTV UPGRADES (DTV)
- BROADBAND FACILITIES

L-2.5CFB

- micro coax
- 24 AWG



.157

L-3CFB

- mini coax
- 22 AWG



.217

L-4CFB

- RG59 type
- 20 AWG



.240

L-5CFB

- RG6 type
- 18 AWG



.303

L-7CFB

- RG11 type
- 15 AWG



.402



Center Conductor: Solid Annealed Copper

Low Loss Dielectric: Foam Polyethylene, strips clean

Aluminum Foil: Easy peel for quick assembly
100% Shield Coverage

Tightly Woven Braid Shield: Tinned Copper

Colors: 7 Matte Finish PVC Jacket Selections

COLORS AVAILABLE					
Model	BLK	BLU	GRN	RED	YEL
L-2.5CFB	■				
L-3CFB	■	■	■	■	
L-4CFB	■	■	■	■	■
L-5CFB	■	■	■	■	■
L-7CFB	■				

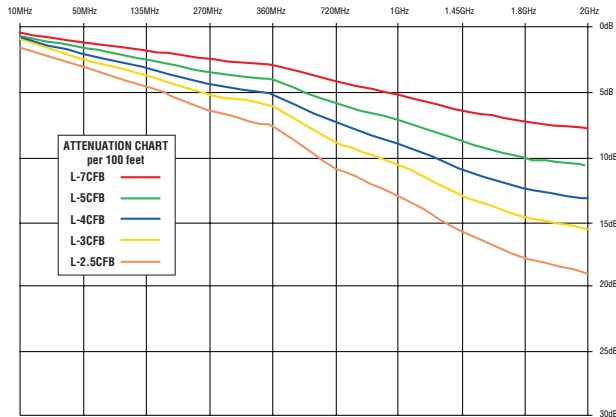

Structural Return Loss

≥20 dB to 2GHz

L-CFB SERIES

CANARE 75Ω precision digital video cable, offers the professional Broadcaster a high performance, 100% Sweep Tested, low cost, low loss coax that meets the demands of today's facility migration trends toward Serial Digital Video and HDTV standards.

Tech Note: Serial Digital video signals are transmitted at very high data bit rates and should be handled quite differently than traditional baseband analog video lines. Typical digital frequency platform bandwidths range from 143 MHz for Composite digital video, 270 MHz for Component digital video and 360 MHz for the proposed HDTV rate. Commonly used 75Ω coaxial cables like RG59 and 8281 are generally acceptable for analog baseband video and may even be used for short runs of digital video transmission. But, in a modern facility system design, where new SERIAL DIGITAL equipment installations require long tie lines and multiple I/O's, it is important to consider the 75Ω Coaxial Cable selection along with "Impedance Matching" BNC Connectors and Patchbays to maximize the overall electrical length and achieve optimum results.

Model	MECHANICAL SPECIFICATIONS										ELECTRICAL PERFORMANCE					
	Stand. Length	Weight Stand. Length lbs (kgs)	Nom. O. D. inch (mm)	PVC Jacket Thickness inch (mm)	Brittle Point °F (°C)	Conductor Material AWG	Cond. O.D. inch (mm)	Dielectric Insulation Type *	Insulation O.D. inch (mm)	Shield Materials & Coverage	Cond. D.C.R. Ω/1000ft (Ω/100m)	Shield D.C.R. Ω/1000ft (Ω/100m)	Nom. Cap. @1KHz pF/ft (pF/mt)	Nom. Imped. Ohms	Velocity of Prop.	Serial Digital Transmission Lengths @ 270 MHz **
L-2.5CFB	984ft 300m	17 7	.157 4.0	.020 0.5	-22 -30	Bare Copper 25	.02 .5	Foam PE	.094 2.4	Al Foil 100% TAC Braid >92%	<28.35 <9.3	<7.3 <2.4	17 55	75Ω	79%	470 ft min. 614 ft max.
L-3CFB	984ft 300m	29 13	.217 5.5	.035 .9	-22 -30	Bare Copper 22	.026 .65	Foam PE	.122 3.1	Al Foil 100% TAC Braid >91%	<16.8 <5.5	<4.3 <1.4	17 55	75Ω	79%	650 ft min. 830 ft max.
L-4CFB	984ft 300m	33 15	.240 6.1	.035 0.9	-22 -30	Bare Copper 20	.032 0.80	Foam PE	.146 3.7	Al Foil 100% TAC Braid >93%	<11.0 <3.6	<3.0 <1.0	17 55	75Ω	79%	710 ft min. 920 ft max.
L-5CFB	984ft 300m	49 22	.303 7.7	.043 1.1	-22 -30	Bare Copper 18	.041 1.05	Foam PE	.192 4.9	Al Foil 100% TAC Braid >93%	<7.0 <2.3	<2.1 <0.7	17 55	75Ω	79%	940 ft min. 1,210 ft max.
L-7CFB	984ft 300m	86 39	.402 10.2	.039 1.0	-22 -30	Bare Copper 15	.059 1.50	Foam PE	.287 7.3	Al Foil 100% TAC Braid >96%	<3.1 <1.0	<1.4 <0.5	17 55	75Ω	79%	1,280 ft min. 1,660 ft max.

* Dielectric Strength = 100V AC / 1min. Insulation resistance/3Mft = >1000MΩ.

** For reference only.

Model	CABLE / CONNECTOR ASSEMBLY ITEMS					
	CANARE 75Ω Connectors			Cable Stripper	Crimp Tool	Die Set
	BNC	F	RCA			
L-2.5CFB	BCP-C25F	-	-	TS100E	TC-1	TCD-35CA
L-3CFB	BCP-C3F	FP-C3F	RCAP-C3F	TS100E	TC-1	TCD-35CA
L-4CFB	BCP-C4F	FP-C4F	RCAP-C4F	TS100E	TC-1	TCD-451CA
L-5CFB	BCP-C5FA	FP-C5F	RCAP-C5F	TS100E	TC-1	TCD-5CF
L-7CFB	BCP-C7FA	FP-C7FA	-	TS100E	TC-1	TCD-7CA

Model	NOMINAL ATTENUATION VALUE									
	10MHz	50MHz	135MHz	270MHz	360MHz	720MHz	1GHz	1.45GHz	1.8GHz	2GHz
L-2.5CFB	1.6 5.8	3.1 10.5	4.6 15	6.5 21.2	7.6 24.8	10.9 35.7	13.0 44.4	15.8 52.0	17.8 58.4	18.9 62.0
L-3CFB	1.0 3.2	2.5 8.0	3.7 12.3	5.2 17.2	6.1 20.0	8.9 29.1	10.6 34.7	13.0 42.6	14.7 48.3	15.6 51.2
L-4CFB	0.9 2.9	2.0 6.6	3.1 10.2	4.4 14.5	5.1 16.7	7.4 24.3	8.9 29.1	10.9 35.8	12.4 40.7	13.2 43.3
L-5CFB	0.7 2.2	1.6 5.3	2.5 8.1	3.5 11.5	4.1 13.4	5.9 19.4	7.1 23.3	8.8 29.0	10.1 33.1	10.7 35.1
L-7CFB	0.5 1.6	1.2 3.8	1.8 5.8	2.5 8.1	2.9 9.4	4.2 13.9	5.2 16.8	6.4 21.0	7.3 24.1	7.8 25.7

APPLICATIONS

- SERIAL DIGITAL VIDEO (SDI)
- HDTV UPGRADES (DTV)
- COMPONENT ANALOG VIDEO
- VIDEO WALLS
- HI-RES VIDEO PROJECTION
- CG / CAD WORKSTATIONS

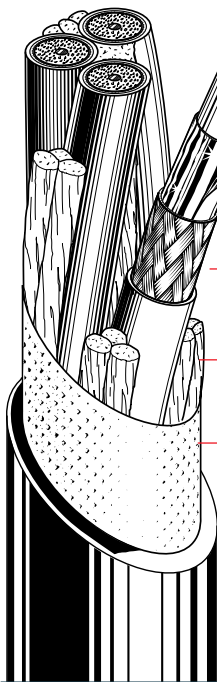

- Center Conductor:** Solid Annealed Copper
- Low Loss Dielectric:** Foam Polyethylene, strips clean
- Aluminum Foil:** Easy peel for quick assembly
100% Shield Coverage
- Tightly Woven Braid Shield:** Tinned Copper
- Special Jacket Fillers:** Maintains tight bundle, reduces Shift & Twist
- Color Coded Channel ID:** Red, Green, Blue, White, Yellow

V-CFB SERIES

Newly developed coax specifically designed for **DIGITAL** and next generation HDTV facilities. Each coaxial channel includes a **Foam Core PE** dielectric, Solid Bare Copper Center Conductor and double Foil/Braid Shield. < 2.2 nano second channel-to-channel differential delay time, reduces phase errors in component video setup alignments. Bundled cable helps keep work site neat and clean. Can be used with confidence for Super Hi-Res CG workstation interconnects and Digital Video installations.

V-3CFB

- mini coax type
- 22 AWG



.173

V-4CFB

- RG59 type
- 20 AWG



.197

V-5CFB

- RG6 type
- 18 AWG



.256

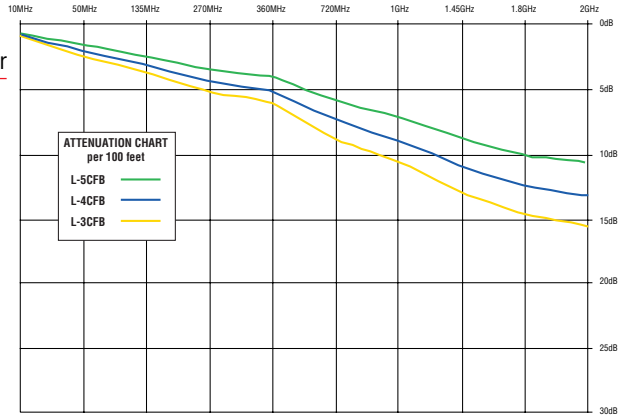

Structural Return Loss
≥20 dB to 2GHz

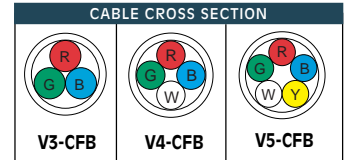

Model	MECHANICAL SPECIFICATIONS											ELECTRICAL PERFORMANCE						
	Stand. Length	Number of Channels (colors)	Wgt. Stand. Lng. lbs (kgs)	Nom. O.D. inch (mm)	PVC Jacket Thick. inch (mm)	Brittle Point °F (°C)	Indv. Chan. O.D. (in.) (mm.)	Insul. Type *	Insul. O.D. (in.) (mm.)	Cond.- AWG (Qty./mil.) Cross Sec. Area (mil²)	Cond. O.D. (in.) (mm.)	Shield Coverage	Cond. D.C.R. (Ω/1000ft) (Ω/100m)	Shield D.C.R. (Ω/1000ft) (Ω/100m)	Nom. Cap. (pF/ft) (pF/m)	Nominal Impedance	Chan. Diff. Delay 100ft (ns)	Velocity of Prop.
V3-3CFB	984ft 300m	3 RED, GRN BLUE	93 42	.453 11.5	.035 .90	-22 -30	.173 4.4	FPE	.122 3.1	AC-#22 1/25.6 512	.026 .65	TAC >91% AL Foil 100%	<17.1 <5.6	<4.3 <1.4	17 55	75Ω	<2.2	79%
V4-3CFB		4 RED, GRN BLUE, WHT	126 57	.512 13.0	.043 1.10													
V5-3CFB		5 RED, GRN BLUE, WHT YEL	153 69	.559 14.2	.043 1.10													
V3-4CFB	984ft 300m	3 RED, GRN BLUE	120 54	.508 12.9	.039 1.0	-22 -30	.197 5.0	FPE	.146 3.7	AC-#20 1/31.5 775	.031 .80	TAC >93% AL Foil 100%	<11.3 <3.7	<3.0 <1.0	17 55	75Ω	<2.2	79%
V4-4CFB		4 RED, GRN BLUE, WHT	153 69	.567 14.4	.043 1.1													
V5-4CFB		5 RED, GRN BLUE, WHT YEL	192 87	.634 16.1	.047 1.2													
V3-5CFB	984ft 300m	3 RED, GRN BLUE	192 87	.673 17.1	.051 1.3	-22 -30	.256 6.5	FPE	.192 4.9	AC-#18 1/41.3 1341	.041 1.05	TAC >93% AL Foil 100%	<7.1 <2.4	<2.1 <0.7	17 55	75Ω	<2.2	79%
V4-5CFB		4 RED, GRN BLUE, WHT	240 109	.740 18.8	.051 1.3													
V5-5CFB		5 RED, GRN BLUE, WHT YEL	306 139	.831 21.1	.059 1.5													

* Dielectric Strength = 500V AC / 1min. Insulation resistance/3Mft = >1000MΩ.

Model	CABLE / CONNECTOR ASSEMBLY ITEMS					
	CANARE 75Ω Connectors			Cable Stripper	Crimp Tool	Die Set
BNC	F	RCA				
V-3CFB	BCP-C3F	FP-C3F	RCAP-C3F	TS100E	TC-1	TCD-35CA
V-4CFB	BCP-C4F	FP-C4F	RCAP-C4F	TS100E	TC-1	TCD-451CA
V-5CFB	BCP-C5FA	FP-C5F	RCAP-C5F	TS100E	TC-1	TCD-5CF

Model	NOMINAL ATTENUATION VALUE									
	10MHz	50MHz	135MHz	270MHz	360MHz	720MHz	1GHz	1.45GHz	1.8GHz	2GHz
V-3CFB	1.0 3.2	2.5 8.0	3.7 12.3	5.2 17.2	6.1 20.0	8.9 29.1	10.6 34.7	13.0 42.6	14.7 48.3	15.6 51.2
V-4CFB	0.9 2.9	2.0 6.6	3.1 10.2	4.4 14.5	5.1 16.7	7.4 24.3	8.9 29.1	10.9 35.8	12.4 40.7	13.2 43.3
V-5CFB	0.7 2.2	1.6 5.3	2.5 8.1	3.5 11.5	4.1 13.4	5.9 19.4	7.1 23.3	8.8 29.0	10.1 33.1	10.7 35.1

APPLICATIONS

- BROADCAST TRANSMISSION
- ANALOG & DIGITAL
- ENG/EFP
- INTER-RACK WIRING
- VIDEO PATCH CORDS

L-1.5C2VS

- Micro coax
- 31 AWG



.114

L-3C2VS

- mini coax
- 25 AWG



.217

LV-61S

- RG59 type
- 24 AWG



.240

LV-77S

- 8281F type
- 22 AWG



.303

Structural Return Loss

≥20 dB to 2GHz

Flexible Center Conductor: Stranded Bare Copper

Dielectric: Polyethylene, strips clean

Double Braid Shields: 95% over 92% Bare Copper

Tightly Woven Braid Shield: >94% Bare Copper

LV-77S

An amazingly *flexible version of 8281* double shielded precision 75Ω video coax. Typically used for longer cable runs between equipment, Canare LV-77S offers good return loss characteristics and excellent signal isolation. Available in 10 different non-glare PVC jacket colors.

LV-61S

Canare's **No.1 Selling Coax**. A lightweight, very flexible **RG59B/U** equivalent that is perfect for all video facility equipment interfacing, ENG/OB work and video patch cord assemblies. Our smooth non-glare finish PVC jackets are available in 10 distinctive colors (including **Chroma-Key Blue!**) and will stay flexible even in sub-zero weather!

L-3C2VS

Our thinnest 75Ω coax is both lightweight and super flexible, an ideal choice for all short run inter-rack control room wiring. This is the same cable type being used inside our most popular RGB component video cable; **V-3C** series.

COLORS AVAILABLE

Model	BLK	BLU	BRN	GRY	GRN	ORN	PPL	RED	WHT	YEL
L-1.5C2VS	■									
L-3C2VS	■	■			■			■		
LV-61S	■	■	■	■	■	■	■	■	■	■
LV-77S	■	■	■	■	■	■	■	■	■	■

Model	MECHANICAL SPECIFICATIONS									ELECTRICAL PERFORMANCE						
	Standard Length	Weight Stand. Length lbs. (kgs)	Nom. O. D. inch (mm)	PVC Jacket Thickness inch (mm)	Brittle Point °F (°C)	Cond - AWG (Qty./mil.) Cross Sec. Area	Cond. O.D. inch (mm)	Insul. Type *	Insul. O.D. inch (mm)	Shield Material Coverage	Cond. D.C.R. Ω/1000ft (Ω/100m)	Shield D.C.R. Ω/1000ft (Ω/100m)	Nom. Cap. (1KHz) pF/ft (pF/mt)	Nom. Imp.	Nom. Attn. (10MHz) dB/1000ft (dB/100m)	Velocity of Prop.
L-1.5C2VS	656ft 200m	5.8 2.6	.114 2.9	0.02 0.5	-22 -30	AC-#31 7/0.09	.011 0.27	PE	.061 1.55	AC >94%	<127.7 <41.9	<9.94 <3.26	21 67	75Ω	29.3 9.6	66%
L-3C2VS	656ft 200m	20 9.1	.217 5.5	.039 1.0	-22 -30	AC-#25 7/7.09	.021 0.54	PE	.122 3.10	AC >94%	<32.1 <10.5	<5.8 <1.9	21 67	75Ω	15 4.9	66%
LV-61S	500ft 153m	19 8.6	.240 6.1	.039 1.0	-22 -30	AC-#24 7/7.88	.024 0.60	PE	.142 3.60	AC >95%	<25.9 <8.5	<4.0 <1.3	21 67	75Ω	13 4.2	66%
LV-77S	500ft 153m	32 14.5	.303 7.7	.035 0.9	-22 -30	AC-#22 7/10.24	.031 0.78	PE	.189 4.80	AC >92% (inner) >95% (outer)	<15.3 <5.0	<1.8 <0.6	21 67	75Ω	10 3.4	66%

* Dielectric Strength = 1000V AC / 1min. Insulation resistance/3Mft = >1000MΩ.

NEW!

Model	CABLE / CONNECTOR ASSEMBLY ITEMS					
	CANARE 75Ω Connectors			Cable Stripper	Crimp Tool	Die Set
	BNC	F	RCA			
L-1.5C2VS	BCP-C1	-	-	-	TC-1	TCD-1DB
L-3C2VS	BCP-C3B	FP-C3	RCAP-C3A	TS100E	TC-1	TCD-35CA
LV-61S	BCP-C4B	FP-C4	RCAP-C4A	TS100E	TC-1	TCD-451CA
LV-77S	BCP-C77A	-	RCAP-C77	TS100E	TC-1	TCD-5CF

Model		NOMINAL ATTENUATION VALUE									
		1 MHz	10 MHz	50 MHz	100 MHz	150 MHz	200 MHz	400 MHz	700 MHz	900 MHz	1 GHz
L-1.5C2VS	dB/100 ft	0.9	2.9	6.5	9.3	11.3	13.1	18.5	24.5	27.8	29.3
	dB/100m	3.0	9.6	21.5	30.4	37.2	42.9	60.7	80.3	91.1	96.0
L-3C2VS	dB/100 ft	1.5	4.9	11.5	16.3	19.9	22.9	31.0	41.5	46.5	49.0
	dB/100m	5.0	15.5	37.5	53.5	65.5	74.5	100.5	132.5	148.5	157.5
LV-61S	dB/100 ft	0.4	1.3	2.7	4.1	5.0	5.7	8.1	10.7	12.1	12.8
	dB/100m	1.3	4.2	9.0	13.3	16.3	18.8	26.6	35.1	39.8	42.0
LV-77S	dB/100 ft	0.3	1.0	2.4	3.3	4.0	4.6	6.6	8.6	9.8	10.4
	dB/100m	1.1	3.4	7.8	10.8	13.2	15.2	21.5	28.4	32.3	34.0

APPLICATIONS

- COMPONENT ANALOG VIDEO
- VIDEO WALLS
- VIDEO PROJECTORS
- STUDIO TIE LINES
- CG WORKSTATIONS

V-1.5C

- Micro coax
- 31 AWG



.102

V-3C

- RG59 type
- 25 AWG



.173

V-5C

- 8281F type
- 22 AWG



.237

Structural Return Loss
≥20 dB to 2GHz

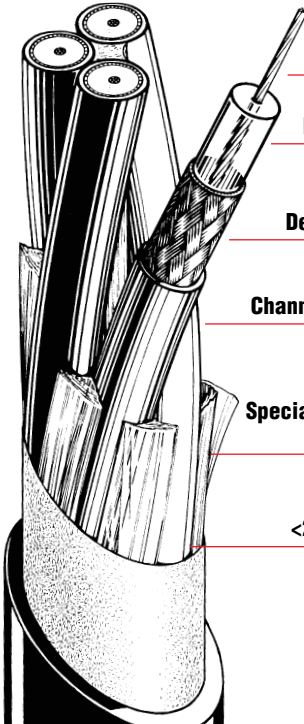

Flexible Center Conductor: Stranded Bare Copper

Dielectric: Polyethylene, strips clean

Dense Braid Shield: Bare Copper

Channel ID Colors: Red, Green, Blue, White, Yellow

Special Jacket Fillers: Maintains tight bundle, reduces Shift & Twist

<2.2 nanosecond differential delay

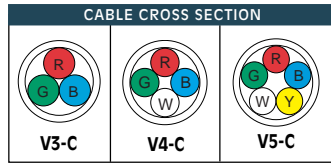

V-1.5C SERIES

New Canare Ultra-Mini V-Series! Offers excellent flexibility and reduced overall jacket OD. Specifically designed for **very short run RGB** fan-out cables, where robust pulling strength and high bandwidth is not a key factor. Terminate with Canare's newly developed 75Ω BNC Plug **BCP-C1** (Not Shown in catalog. Features a Solder Pin and Crimp Sleeve).

V-3C SERIES

Our most popular 75Ω component video series. Roughly equivalent to RG59 performance. A good choice for limited length cable runs or where conduit size may be restricted. Excellent flexibility for untangled pay-out and easy wrap-ups.

V-5C SERIES

Offers 8281 type performance for extra long cable runs over wide bandwidth RGB component analog systems. Also highly recommended for field operations where cable flex strength and maximum durability is a must.

Model	MECHANICAL SPECIFICATIONS											ELECTRICAL PERFORMANCE							
	Std. Lng.	Number of Channels colors	Wgt. Stand. Lng. lbs/ (kgs)	Nom. O.D. inch (mm)	PVC Jacket Thick. inch (mm)	Brittle Point °F (-°C)	Indv. Chan. O.D. inch (mm)	Insul. Type *	Insul. O.D. inch (mm)	Cond.- AWG (Qty./mil.) Cross Sec. Area	Cond. O.D. inch (mm)	Shield Coverage	Cond. D.C.R. Ω/1000ft (Ω/100m)	Shield D.C.R. Ω/1000ft (Ω/100m)	Nom. Cap. pF/ft (pF/m)	Nom. Imp.	Nom. Attn. 10MHz dB/1000ft (dB/100m)	Chan. Diff. Delay 100ft (ns)	Velocity of Prop.
V3-1.5C		3 RED, GRN BLUE	16/7	.291 7.4	.032 0.8														
V4-1.5C	328ft 100m	4 RED, GRN BLUE, WHT	21/10	.331 8.4	.039 1.0	-22 -30	.102 2.6	PE	.061 1.55	AC-#31 7/3.5	.011 .27	>94%	<129.2 <42.4	<10.1 <3.3	21 69	75Ω	29.3 9.6	<2.2	66%
V5-1.5C		5 RED, GRN BLUE, WHT YEL	24/11	.362 9.2	.039 1.0														
V3-3C		3 RED, GRN BLUE	33/15 66/30	.453 11.5	.036 0.9														
V4-3C	328ft 100m	4 RED, GRN BLUE, WHT	44/20 88/40	.512 13.0	.043 1.1	-22 -30	.173 4.4	PE	.122 3.1	AC-#25 7/7.09	.021 0.54	>97%	<32.1 <10.5	<3.7 <1.1	21 67	75Ω	15.0 4.9	<2.2	66%
V5-3C	656ft 200m	5 RED, GRN BLUE, WHT YEL	53/24 106/48	.559 14.2	.043 1.1														
V3-5C		3 RED, GRN BLUE	51/23 102/46	.611 15.5	.047 1.2														
V4-5C	328ft 100m	4 RED, GRN BLUE, WHT	66/30 132/60	.674 17.1	.047 1.2	-22 -30	.237 6.0	PE	.189 4.8	AC-#22 7/10.24	.031 0.78	>94%	<15.5 <5.1	<3.7 <1.2	21 67	75Ω	10.0 3.4	<2.2	66%
V5-5C	656ft 200m	5 RED, GRN BLUE, WHT YEL	84/38 168/76	.756 19.2	.055 1.4														

* Dielectric Strength = 500V AC / 1min. Insulation resistance/3Mft = >100MΩ.

Model	CABLE / CONNECTOR ASSEMBLY ITEMS					
	CANARE 75Ω Connectors			Cable Stripper	Crimp Tool	Die Set
	BNC	F	RCA			
V-1.5C	BCP-C1	-	-	-	TC-1	TCD-1DB
V-3C	BCP-C3B	FP-C3	RCAP-C3A	TS100E	TC-1	TCD-35CA
V-5C	BCP-C5B	FP-C5	RCAP-C5A	TS100E	TC-1	TCD-35CA

Model		NOMINAL ATTENUATION VALUE									
		1 MHz	10 MHz	50 MHz	100 MHz	150 MHz	200 MHz	400 MHz	700 MHz	900 MHz	1 GHz
V-1.5C	dB/100 ft dB/100m	0.9 3.0	2.9 9.6	6.5 21.5	9.3 30.4	11.3 37.2	13.1 42.9	18.5 60.7	24.5 80.3	27.8 91.1	29.3 96.0
V-3C	dB/100 ft dB/100m	0.5 1.5	1.5 4.9	3.2 10.4	4.7 15.5	5.8 19.0	6.7 21.9	9.4 31.0	12.5 41.0	14.2 46.5	14.9 49.0
V-5C	dB/100 ft dB/100m	0.3 1.1	1.0 3.4	2.4 7.8	3.3 10.8	4.0 13.2	4.6 15.2	6.6 21.5	8.6 28.4	9.8 32.3	10.4 34.0

THE STAR QUAD STORY

Canare Star Quad obtains its name from the 4-conductor style construction that minimizes the “loop area” between twists of the conductors. This “double balanced” pairing, reduces susceptibility to electromagnetically induced noise. The improvement in noise rejection is so noticeable that even SCR dimmer noise (stage lighting consoles) is reduced to less than 1/10 the level found in other 2-conductor microphone cables.

Canare Star Quad is designed for use with microphones but is also excellent for all line-level signals (e.g. mixer to power amps). The 4-conductor Star Quad arrangement cancels electromagnetically induced noise from

SCR dimmer packs, fluorescent lighting ballasts and AC power transformers. Handling noise is prevented by use of cotton filler material. Excellent frequency response is maintained due to special irradiated polyethylene insulation which provides a low capacitance dielectric.

Canare Star Quad cable is super flexible. We use large numbers of thin wire strands in the copper conductors and overall braided shield. We extrude a special compound PVC outer jacket that remains pliant at extremely low temperatures with no wait between cold shipping and installation.

Filler

Canare selects cotton, jute and/or exotic polyester fibers for packing. These fillers prevent stretching and twisting of the inner conductors which can cause noise. Additionally, paper, Mylar and/or cloth tape, bind conductors so cables hold their shape.

Conductors

All Canare microphone cables utilize high-conductivity, annealed copper wires, stranded to form flexible conductors and shields.

Jacket

Canare uses specially formulated PVC compounds that combine to make a tough, strong and durable outer jacket with excellent flexibility. These qualities are retained even at very low temperatures, so Canare Cables will not stiffen or crack. Available in 10 attractive colors.

Insulation

Canare Cables utilize special polymer compounds that reduce capacitive “R-C” filter roll off within the cable and prevent high voltage breakdown. By irradiating the material, the polymer becomes extensively cross-linked, chemically inert, water resistant, and remains flexible at very low temperatures. Irradiated PE is superior to ordinary polyethylene because it is heat resistant. Canare insulation will not shrink back, flow or char when soldering, so you save initial and rework time, and achieve more reliable connections.

Shield

Canare does *not* use spiral (serve) shields because they can spread apart with use. Our shields are more difficult to manufacture because we use many thin copper strands in a densely woven braid. The shields are super flexible and offer outstanding noise rejection.

In order to maximize noise rejection, Star Quad must be properly wired to the XLR-3 connector (or terminal block).

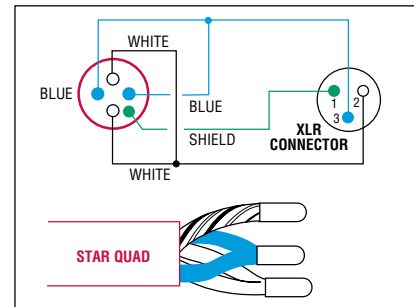

Because the shield density on Canare Cable is very high, it is somewhat difficult to push back the braid and pull the inner conductors through. Instead, we strongly recommend unbraiding the shield by “combing” it out with a pointed tool, beginning at the end of the cable.

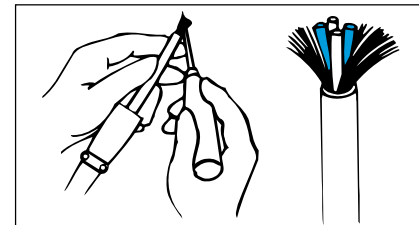

Terminating L-4E6S and L-4E5C (Braid Shield)

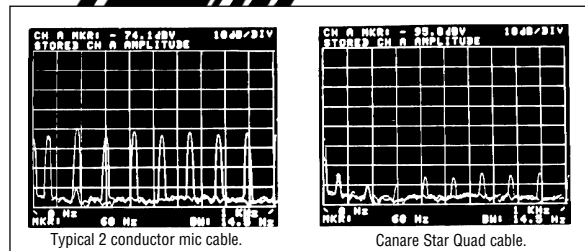

TECHNICAL NOTE The signal generated by a microphone during quiet periods can be very low in level, -70dB to -120dB (0.3 millivolts to 1 microvolt). The cable that must carry this signal to the mixer is very sensitive to Electromagnetic Interference (EMI), Radio Frequency Interference (RFI) and electrostatic coupling of hum and noise. Mechanical vibration, bending, flexing (handling noise) and ambient temperature fluctuations can cause detrimental capacitance changes within the microphone cable. Canare Cables are carefully designed and manufactured to very close tolerances using the highest quality materials available so that low level microphone circuits will not be affected by these outside disturbances. The difference is clearly measurable and audible.

For a more detailed illustration, please request our Technical White Paper: “Evaluating Microphone Cable Performance and Specifications.”

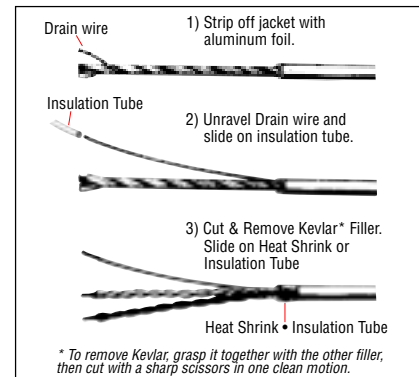

Terminating L-4E5AT and L-4E6AT (Foil Shield)

* To remove Kevlar, grasp it together with the other filler, then cut with a sharp scissors in one clean motion.

APPLICATIONS

- MICROPHONES
- AUDIO RACK WIRING
- PA SYSTEMS
- AUDIO PATCH CORDS

FEATURES

- Copper Braid or Aluminum Foil Shields**
- Cross-Linked PE Insulation**
- Reduced Handling Noise**
- Rejects EMI and RFI**
- 10 Matte Color Jacket Selections**
- Flexible in Extreme Cold Weather**



Some models are available on a convenient 100% Recyclable Paper Spool for easy dispensing.

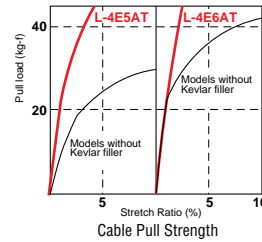
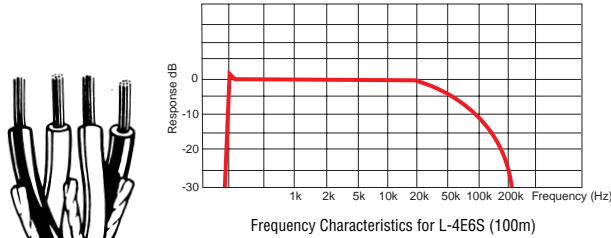

For Portable Applications
Braided Copper Shield

L-4E6S

The premier Star Quad cable for all hand held microphone applications. Flexible, satin smooth to the touch and extra-strong, this standard diameter, 21 AWG cable fits perfectly in all XLR-type audio connectors. Forty separate strands in each conductor eliminate breakage due to flexing. Available in 10 beautiful matte finish color jackets.

L-4E5C

A narrow profile version of L-4E6S. Specifically designed to save space and reduce weight during remote field expeditions or confining installations.



For Permanent Installations
Foil Shield with Drain Wire

L-4E6AT

A 20 AWG Star Quad cable specifically designed for point to point wiring in fixed installations. **Aluminum Foil** Shielding provides 100% coverage. Slick, easy to pull PVC Jacket. Cable internally reinforced with **Dupont Kevlar 29** filler, stronger than steel, can resist stretching or kinking of wires when pulled through conduit bends. Foil shield & drain wire strips easily for quick assembly work (1/3 the assembly time of braided shields). Irradiated PE conductor insulation resists solder iron meltdown.

L-4E5AT

A 22 AWG narrow profile Star Quad audio cable with the same shield, drain wire and **Kevlar** construction style as L-4E6AT.

COLORS AVAILABLE										
Model	BLK	BLU	BRN	GRY	GRN	ORN	PPL	RED	WHT	YEL
L-4E6S	■	■	■	■	■	■	■	■	■	■
L-4E5C	■	■	■	■	■	■	■	■	○	■
L-4E6AT	●	■	■	■	■	■	■	■	○	■
L-4E5AT	●	■	■	■	■	■	■	■	○	■

□ = Standard Stock ○ = Special Order

Model	MECHANICAL SPECIFICATIONS										ELECTRICAL PERFORMANCE / QUAD						
	Standard Length	Wgt. Stand. Length	Nom. O.D.	Jacket Nom. Thick.	Brittle Point	No. of Cond.	Insul. Type Thick.	Cond - AWG (Qty./mil) Cross Sec. Area mil. ²	Pitch Twist Quad	Shield Coverage	Cond. D.C.R.	Shield D.C.R.	Nom. Cap. ***	Nom. Cap. †	Nom. Imp.	Nom. Atten.	Group Delay Time
	ft	lbs (kgs)	inch (mm)	inch (mm)	°F (°C)		mil	**Quad AWG	inch (mm)	%	Ω/1000ft (Ω/100m)	Ω/1000ft (Ω/100m)	pF/ft (pF/m)	pF/ft (pF/m)	(Ω)	V/1000ft (V/100m)	nS/ft (nS/m)
L-4E6S	656 ft 200m 1000 ft 305m	24 11 35 16	.236 6.00	PVC .044 1.12	-56 -49	4 2 Blue 2 Wht	IPE 15.7	AC - #24 40/3.15 310 #21	.79 20	>95% TAC Braid	<29.9 <9.8	<-9.1 <3.0	46 150	57 185	44	0.9 0.3	1.80 5.9
L-4E5C	656ft 200m	18 8	.189 4.80	PVC .032 0.80	-56 -49	4 2 Blue 2 Wht	IPE 11.8	AC - #26 30/3.15 232.5 #23	.71 18	>96% TAC Braid	<39.7 <13.0	<-7.6 <2.5	50 162	61 200	40	0.9 0.3	1.71 5.6
L-4E5AT	656ft 200m	16 7	.197 5.00	PVC .039 1.03	-22 -30	4 2 Blue 2 Wht	IPE 12.6	AC - #25 16/4.73 279 #22	.83 21	100% Alum. Tape **	<32.7 <10.7	—	50 164	68 222	37	0.9 0.3	1.71 5.6
L-4E6AT	656ft 200m	23 10	.244 6.20	PVC .047 1.20	-22 -30	4 2 Blue 2 Wht	IPE 15.7	AC - #23 12/7.09 481 #20	.99 25	100% Alum. Tape ‡	<19.4 <6.4	—	46 150	64 210	37	0.6 0.2	1.68 5.5

*Dielectric Strength = 500V AC / 1min. Insulation resistance/3Mft = >1000MΩ. ** Effective AWG of combined twin conductors. *** Capacitance between twin Blue and twin White Conductors. † Capacitance between conductors to shield. ‡ Drain Wire #23 AWG. †† Drain Wire #25 AWG.

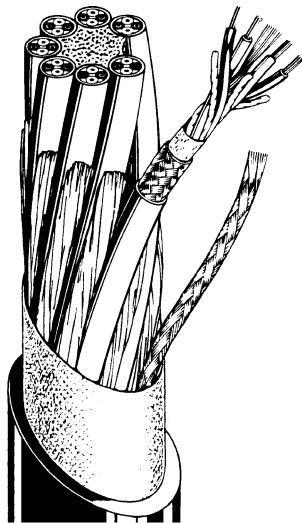

For Portable Applications
Braided Copper Shields

L-4E3-P

A Multichannel Star Quad Snake cable with braided shields. Each channel is completely isolated and consists of 4 conductors surrounded by an overall braided shield encased in a color coded striped PVC jacket. Fine conductor stranding for flexibility, facilitates roll up and easy payout. The four conductor design provides superior EMI and RFI noise rejection in problem areas on stage. Excellent crosstalk characteristics allow vastly different signals (-120dB mic, +4dB line, +10dB time code levels) to be used in adjacent channels.

Note: All Canare DT12 Snake assemblies are built using our road-worthy and flexible L-4E3-12P cable.

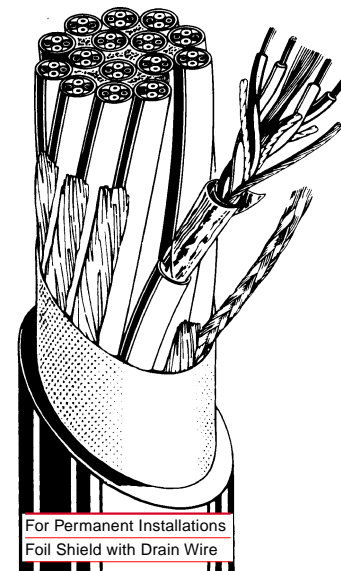

For Permanent Installations
Foil Shield with Drain Wire

L-4E4-AT

A 100% shielded Canare Star Quad Multichannel Snake cable, designed for all fixed audio installations. Each four conductor channel is completely isolated and contains Kevlar 29 for tensile pulling strength. Individual foil shield, drain wire and color banded PVC channel jacket strips easily for quick on-site termination.

MECHANICAL SPECIFICATIONS

Model	Standard Length	No. of Quad Channels	Weight 328ft 100m lbs/(kgs)	Nom. O.D. inch	PVC Jacket Nom. Thick. inch/(mm)	Brittle Point °F (°C)	Number of Cond. (4 per Channel)	Channel O.D. Inch (mm)	Channel Jacket Nom. Thick. mil	Insul. Type * Thick mil	Cond - AWG (Qty./mil) Cross Sec. Area (mil. ²)	Pitch Twist Quad Inch (mm)	Shield Coverage Channel Drain Wire (Bundle Drain Wire)
L-4E3-2P	328ft 100m	2	18/8	.350	.032/0.8	-22 -30	8	.134	PVC	IPE	AC-#28	<0.63	AC Braid >93%
L-4E3-4P		4	31/14	.429	.043/1.1		16				7/4.72		
L-4E3-8P		8	57/26	.602	.051/1.3		32				124 #25		
L-4E3-12P	656ft 200m	12	79/36	.685	.051/1.3	-22 -30	48	3.4	11.8	10.6	124 #25	<16	- (20AWG)
L-4E3-16P		16	101/46	.744	.047/1.2		64						
L-4E3-24P		24	154/70	.945	.059/1.5		96						
L-4E4-2AT	328ft 100m	2	18/8	.413	.051/1.3	-22 -30	8	.146	PVC	IPE	AC-#25	<0.83	AL Foil 100%
L-4E4-4AT		4	40/18	.484	.055/1.4		16				16/4.73		
L-4E4-8AT		8	73/33	.665	.059/1.5		32				279 #22		
L-4E4-12AT	656ft 200m	12	95/43	.748	.059/1.5	-22 -30	48	3.7	11.8	12.6	279 #22	<21	23AWG (16AWG)
L-4E4-16AT		16	117/53	.827	.059/1.5		64						
L-4E4-24AT		24	152/69	1.031	.067/1.7		96						

* Dielectric Strength = 500V AC / 1min. Insulation resistance/3Mft = >1000MΩ.

** Effective AWG of combined twin conductors.

ELECTRICAL PERFORMANCE / QUAD

Model	Cond. D.C.R. (Ω/1000ft) (Ω/100m)	Shield D.C.R. (Ω/1000ft) (Ω/100m)	Nom. Cap. (pF/ft) (pF/m)	Nom. Cap. (pF/ft) (pF/m)	Nom. Imp. (Ω)	Group Delay Time (ns/ft) (ns/m)	X-Talk Input 3.31V (mV/1000ft) (mV/100m)
L-4E3 SERIES	<75.8 <24.9	<10.3 <3.4	44 52	52 170	43	1.8 5.8	<3 <1
L-4E4 SERIES	<32.9 <10.8	—	50 164	68 222	—	—	—

* Capacitance between twin Blue and twin White Conductors.

** Capacitance between conductors to shield.

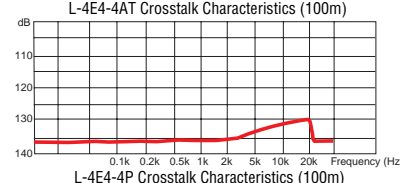
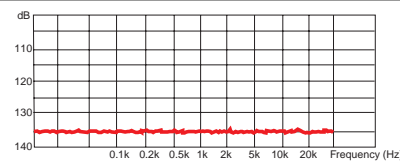

L-4E3-P, L-4E4-AT CROSS SECTION MULTI CHANNEL BUNDLE

CROSS SECTION INDIVIDUAL STAR QUAD CHANNEL

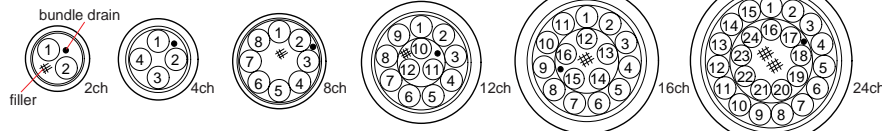
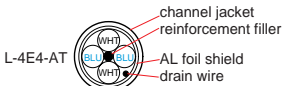
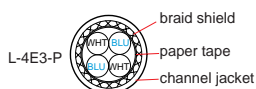

CHANNEL COLOR CODE • SPIRAL MARKERS ON GRAY JACKET

1	2	3	4	5	6	7	8	9	10	11	12	13	14	15	16	17	18	19	20	21	22	23	24
RED	BLU	YEL	GRN	BRN	BARE	BLK	BLK	BLK	BLK	BLK	ORN	ORN	ORN	ORN	ORN	PNK	PNK	PNK	PNK	PNK	WHT	WHT	WHT
						BLU	YEL	GRN	BRN		BLU	YEL	GRN	BRN		BLU	YEL	GRN	BRN		BLU	YEL	GRN



L-2T2S

Our standard diameter 2-conductor microphone cable for general purpose audio applications. The high density braided copper shield and two inner conductors (composed of 60 thin strands of copper wire), allow for maximum flexibility and reduced handling noise. A special compound PVC outer jacket resists cracking and tears even in sub-zero environments.

L-2E5

Miniature version of L-2T2S when small size and light weight is a consideration. Useful for patch cables, hidden lavaliere microphones or any balanced audio installation.



L-2B2AT

Canare's thinnest profile audio hookup wire. Amazingly flexible, with 100% foil shield, drain wire and PVC jacket that strips easily for rapid assembly. Suitable for large cable harness bundles, mixing consoles, tape machines and inter-rack wiring.

COLORS AVAILABLE						
Model	BLK	BLU	GRY	ORN	RED	YEL
L-2T2S	■	●	●	●	●	●
L-2E5	■	●		●	●	
L-2B2AT	●		■			

□ = Standard Stock ○ = Special Order

Model	MECHANICAL SPECIFICATIONS										ELECTRICAL PERFORMANCE						
	Standard Length	Wgt. Stand. Lngth.	Nom. O.D.	PVC Jacket Nom. Thick.	Brittle Point	No. of Cond.	Insul. Type *	Cond - AWG (Qty./mil)	Pitch Twist Quad	Shield Coverage	Cond. D.C.R.	Shield D.C.R.	Nom. Cap. **	Nom. Cap. ***	Nom. Imp.	Nom. Atten.	Group Delay Time
		lbs (kgs)	inch (mm)	inch (mm)	°F (°C)		mil		inch (mm)		Ω/1000ft (Ω/100m)	Ω/1000ft (Ω/100m)	pF/ft (pF/m)	pF/ft (pF/m)	Ω	V/1000ft (V/100m)	mV/1000ft (mV/100m)
L-2T2S	656ft 200m	20 9	.236 6.00	.039 1.0	-56 -49	2	IPE 19.7	AC-#23 60/3.15 465	<0.79 <20	>94% TAC Braid	<19.8 <6.5	<9.4 <3.1	22 70	33 106	88	0.9 0.3	1.83 6.00
L-2E5	656ft 200m	20.2 9	.181 4.6	.035 0.9	-56 -49	2	IPE	AC-#26 30/3.15 322.5	<0.79	>96.7%	<38.7 <12.7	<6.7 <2.2	—	—	—	—	—
L-2B2AT	656ft 200m	6 3	.126 3.2	.012 0.3	-13 -25	2	IPE 12.6	AC-#25 16/4.73 279	<0.99 <25	100% Alum. Tape ****	<31.9 <10.5	—	23 73	37 120	—	—	—
	1640ft 500m	15 7															

* Dielectric Strength = 500V AC / 1min. Insulation resistance/3Mft = >1000MΩ. ** Capacitance between Conductors. *** Capacitance between conductors to shield. **** Drain Wire #22 AWG.

MULTICHANNEL AUDIO SNAKE CABLE

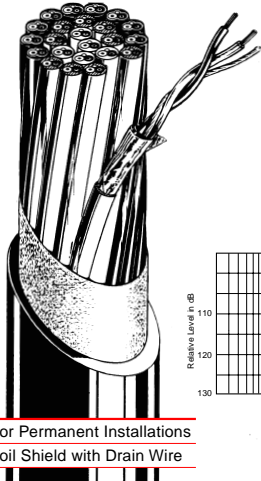

MR202-AT

A practical, 100% foil shielded multichannel audio snake cable for general purpose studio applications. Each individually isolated channel consists of 2 twisted conductors under an easy-to-strip PVC jacket extruded over a foil shield and drain wire. The color striped PVC channel jacket alleviates the need to use costly shrink tubing. Surprisingly flexible, this multichannel cable is perfect for control room layout and interfacing between equipment racks, audio patchbays, mixers and tape decks.

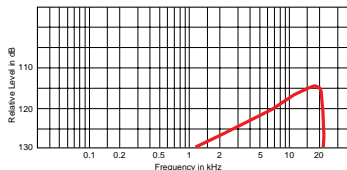

MR202-24AT Crosstalk

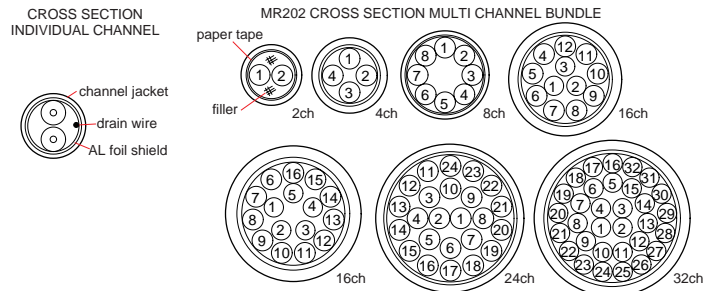

For Permanent Installations
Foil Shield with Drain Wire

Model	MECHANICAL SPECIFICATIONS													ELECTRICAL PERFORMANCE			
	Standard Length	No. of Chan. (Pairs)	Wgt. Stand. Length lbs/ (kgs)	Nom. O.D. inch	PVC Jacket Thickness inch/ (mm)	No. of Cond. (2 Per Chan)	Chan. O.D. Inch (mm)	Chan. Jack. Thick mil	Brittle Point °F (°C)	Insulation Type *	Cond - AWG (Qty./mil)	Pitch of Pairs inch (mm.)	Shield Coverage	Cond. D.C.R.	Nom. Cap. **	Nom. Cap. ***	
										Thick mil				Ω/1000ft (Ω/100m)	pF/ft (pF/m)	pF/ft (pF/m)	
MR202-2AT	328ft 100m	2	12/5	.264	.032/0.8	4	.106 2.7	11.8	-4 -20	IPE	AC - #25 7/7.09 279	<.99 <25	100% Alum. Tape +	<32.5 <10.7	23.2 76	43.3 142	
MR202-4AT		4	17/8	.299	.032/0.8	8											
MR202-8AT		8	35/16	.433	.039/1.0	16											
MR202-12AT		12	46/21	.500	.047/1.2	24											
MR202-16AT		16	57/26	.551	.047/1.2	32											
MR202-24AT		24	86/39	.685	.051/1.3	48											
MR202-32AT		32	88/40	.752	.059/1.5	64											

* Dielectric Strength = 500V AC / 1min. Insulation resistance/3Mft = >1000MΩ. ** Capacitance between Conductors. *** Capacitance between conductors to shield. † Drain Wire #25 AWG.

MR202-AT CHANNEL COLOR CODE																																
Unit No.	1	2	3	4	5	6	7	8	9	10	11	12	13	14	15	16	17	18	19	20	21	22	23	24	25	26	27	28	29	30	31	32
Insulator Color*	BRN	RED	ORN	YEL	GRN	BLU	PPL	GRY	WHT	BLK	BRN	RED	ORN	YEL	GRN	BLU	PPL	GRY	WHT	BLK	BRN	RED	ORN	YEL	GRN	BLU	PPL	GRY	WHT	BLK	BRN	RED
Spiral Marker	BRN	RED	ORN	YEL	GRN	BLU	PPL	GRY	WHT	BLK		RED	ORN	YEL	GRN	BLU	PPL	GRY	WHT	BLK	BRN		ORN	YEL	GRN	BLU	PPL	GRY	WHT	BLK	BRN	RED
Inner Jacket Color	BLK									BRN									RED													

NOTE: Identify the conductor by Spiral Marker and color of Inner Jacket. *Insulator in the unit: one is same color as Spiral Marker and the other is clear.

APPLICATIONS

- ELECTRONIC INSTRUMENTS
- HI-FI INTERCONNECTS
- TEST PROBES
- AUDIO PATCH CORDS
- AMP TO CABINET LEADS

FEATURES

- Stays Flexible even in Sub-Zero Weather**
- Oxygen Free Copper Conductor & Shield**
- Reduced Microphonic Handling Noise**
- Low Capacitance & Resistance**



Conductor

Extra thick 18 AWG Center Conductor composed of **127 strands of Oxygen Free Copper**, resists nicking and corrosion at solder joint. This robust Conductor has been specially designed to cut power loss on Hi-Z guitar pickups and all hot musical instrument signals.

Insulation

Excellent frequency response results from using a special polyethylene dielectric that offers low capacitance and low series resistance.

Special Inner Shield

We use a proprietary conductive polyvinyl carbon sheath that helps dissipate microphonic handling noise from high gain stage amplification.

Outer Shield

Canare uses a special high density braid that is tightly woven with many thin strands of Oxygen Free Copper. Our GS-Series professional level instrument cable will withstand severe flexing, nightly stage workouts & heavy duty studio use.

Jacket

Tough but flexible PVC jacket resists tears and cracks. Stays pliant and will not stiffen, even at sub-zero temperatures. Available in a variety of smooth, satin matte finishes.

GS-6

A specially designed **Oxygen Free Copper** 18 AWG cable for connecting Guitar/Bass or Keyboards to amps, mixers, effects pedals and all outboard signal processing gear. Low capacitance and low series resistance provides improved frequency response (flat to 50kHz). A bright, ringing characteristic sound is preserved, even when using HI-Z guitar pickups with long cable runs. The proprietary double Carbon/Braid Copper shield construction eliminates microphonic handling noise, especially on stage where amps are often set at maximum volume levels. Also highly recommended for Amp Head to Speaker Cabinet leads.

GS-4

Miniature size 22 AWG version of GS-6. Good choice for short run unbalanced audio interconnects and general instrumentation cables.

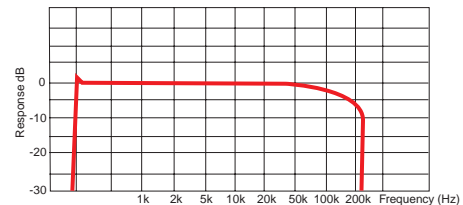

GS-6 Frequency Characteristics (100m, 100Ω > 1MΩ load)

Important Wiring Note:
 Canare GS-4 and GS-6 utilize a specially designed **Conductive Carbon Plastic Shield** to protect against undesirable microphonic handling noise. This inner sleeve can cause a short circuit if allowed to come in contact with the OFC center conductor. Please be very careful when stripping cable and remove this material from exposed insulation before soldering.

COLORS AVAILABLE

Model	BLK	BLU	ORN	RED	YEL
GS-6	■	■	■	■	■
GS-4	■	■	■	■	■

□ = Standard Stock ○ = Special Order

Model	MECHANICAL SPECIFICATIONS								ELECTRICAL PERFORMANCE			
	Stand. Length	Wgt. Stand. Lng.	Nom. O.D.	PVC Jacket Nom. Thick.	Brittle Point	No. of Cond.	Insul. Type *	Cond - AWG (Qty./mil) Cross Sec. Area (mil. ²)	Dual Shield Coverage	Chan. D.C.R.	Shield D.C.R.	Nom Cap **
	ft	lbs (kgs)	inch (mm)	inch (mm)	°F (°C)		mil			Ω/1000ft (Ω/100m)	Ω/1000ft (Ω/100m)	pF/ft at 1KHz (pF/m at 1KHz)
GS-6	656ft 200m	22 10	.228 5.8	.039 1.0	-56 -49	1	PE 33.5	OFC - #18 127/3.94 1550	OFC >92% Braid + Carbon Sleeve	<5.6 <1.8	<7.6 <2.5	49.0 160
GS-4	656ft 200m	12 5	.157 4.0	.028 0.7	-56 -49	1	PE 19.7	OFC - #22 50/3.94 604.5	OFC >93% Braid Carbon Sleeve	<14.7 <4.8	<9.8 <3.2	47.0 154

* Dielectric Strength = 500V AC / 1min. Insulation resistance/3Mft = >1000MΩ.
 ** Capacitance between conductor to shield.

APPLICATIONS

- PA SYSTEMS
- HI-FI SPEAKERS
- DC POWER LINES

FEATURES

- Super Flexibility, even in Sub-Zero Weather**
- Star Quad Design Reduces EMI Noise**
- Low Capacitance & Resistance**

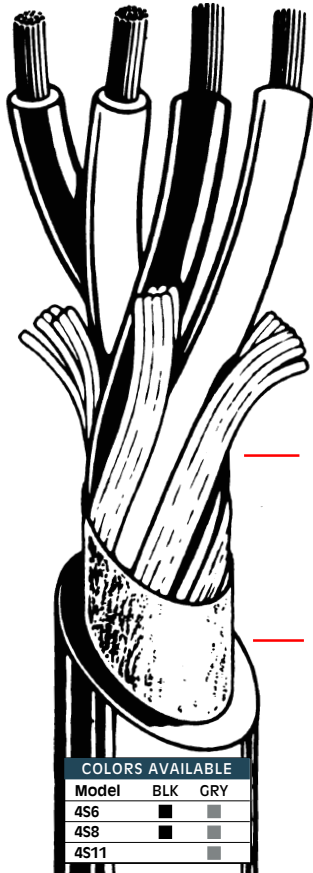

- Conductor**
Canare uses many thin strands of annealed copper for excellent flexibility and long life reliability.
- Insulation**
Special polyethylene dielectric offers low capacitance and low series resistance for improved frequency response over long distance cable runs. Star Quad configuration improves damping factor at the speaker. Individual conductor Color Coding (Red, Clear Red, White, Clear White) allows easy continuity checks.
- Filler**
4S-Series speaker cables use tightly packed cotton fibers to help maintain cable shape and keep conductors from shifting.
- Jacket**
Durable PVC outer jacket. Stays flexible, resists tears and cracks. Will not stiffen even at sub-zero temperatures.

COLORS AVAILABLE

Model	BLK	GRY
4S6	■	■
4S8	■	■
4S11	■	■

Model	MECHANICAL SPECIFICATIONS								ELECTRICAL PERFORMANCE/ QUAD WIRED		
	Std. Lng.	Wt. Std. Lng.	Nom. O.D.	Jacket Thick. PVC	Brittle Point	Number of Conductors	Cond - AWG (Qty./mil) Cross Sec. Area (mil. ²)	Pitch of Quad	Insul. Type	Cond. D.C.R.	Nom. Cap. ***
4S6	656ft 200m	24 11	.252 6.4	.032 0.8		4	AC-#20 20/7.09 791 #17	<1.78 <45	PE 19.7	11.4 3.7	38 125
							* Quad AWG				
4S8	656ft 200m	42 19	.327 8.3	.043 1.1	-56 -49	4	AC-#16 50/7.09 1969 #13	<2.76 <70	PE 19.7	4.5 1.5	44 145
							RED, CLR RED WHT, CLR WHT				
4S11	656ft 200m	70 32	.421 10.7	.047 1.2		4	AC-#14 41/10.24 3379 #11	<4.73 <120	PE 27.6	2.6 0.9	45 146

* Effective AWG of combined twin conductors. *** Capacitance between twin Red and twin White Conductors.
 ** Dielectric Strength = 500V AC / 1min. Insulation resistance/3Mft = >1000MΩ.

DAMPING FACTOR: Always try to keep speaker cables as short as possible and select cable models that offer a higher damping factor; 20-50 for music (i.e. concert sound) and 10-20 for speech (i.e. sport stadiums).

The greater the damping factor (DF), the better the ability to control speaker excursion to create sharp, clear quality in the low end frequency range.

$$\text{Damping Factor} = \frac{\text{speaker impedance}}{\text{power amp. output impedance} + \text{speaker cable cond. resistance}}$$

Values calculated assuming power amplifier output at 0.05Ω

Model	Pair cond. resist. (Ω/100m) & cross-sec (mm ²)	Cond. resist. (Ω/100m) for return path	Cable length/damping factor	DF=20	DF=50
4S6	1.87/1.0mm ² AWG	3.7	9.5m	3.0m	12.6
4S8	0.75/2.5mm ² AWG	1.5	23.3	7.3	
4S11	0.43/4.3mm ² AWG	0.87	40.2	12.6	

As the below formula shows, a higher conductor resistance causes a lower damping factor, which prevents power amps from performing at peak optimum levels.

4S6 (17 GAUGE / STAR QUAD)

A lighter gauge, very flexible speaker cable, using 4 x 20 AWG insulated conductors. Good choice for high frequency components, short line runs or DC power cords.

4S8 (13 GAUGE / STAR QUAD)

Our most popular 4 x 16 AWG flexible speaker cable. Perfect choice for all broad spectrum speaker systems and general purpose power amp setups. Good on Bi-Amp rigs.

4S11 (11 GAUGE / STAR QUAD)

Recommended for long runs and low end Power Amplifier sub-woofer systems. Heavy duty 4 x 14 AWG conductors.

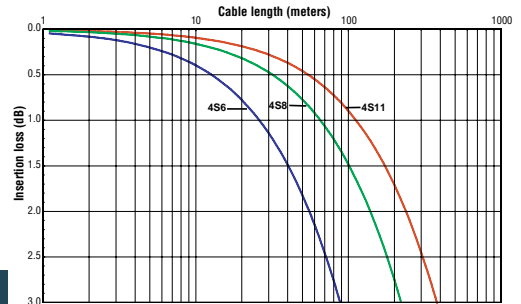
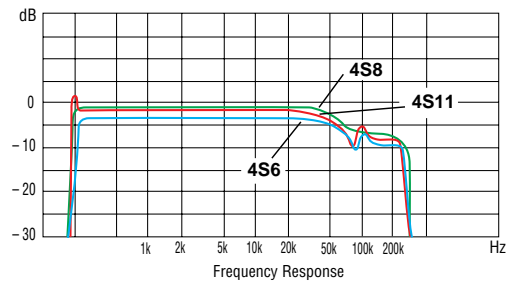

Insertion loss of 4S series speaker cable

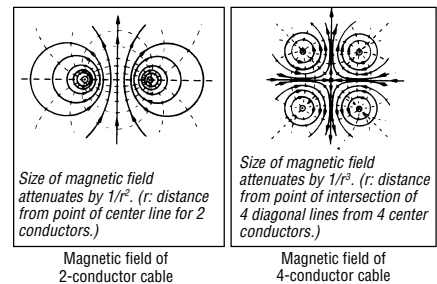

TECH NOTE: Speaker cable must accommodate relatively high signal levels, typically tens to hundreds of watts of RMS power. Electromagnetic interference (EMI) can radiate from these speaker lines directly into adjacent low voltage cables (i.e. microphone, video lines, etc.). Canare solves this problem by using a 4-conductor "Star Quad" configuration in all of our 4S-Series speaker cables. Because every conductor is located the same distance from the center, the opposing magnetic fields are cancelled out. Attenuation of magnetic field radiation is superior when compared to a standard 2-conductor speaker wire.

APPLICATIONS

- OB VANS
- ENG/EFP
- A/V COMBO SNAKES

FEATURES

- Audio + Video in Same Cable Bundle**
- Stays Flexible even in Sub-Zero Weather**
- Special Fillers prohibit Cable Component Twisting**
- Use with Canare 75Ω BNC, F or RCA Crimp Plugs**

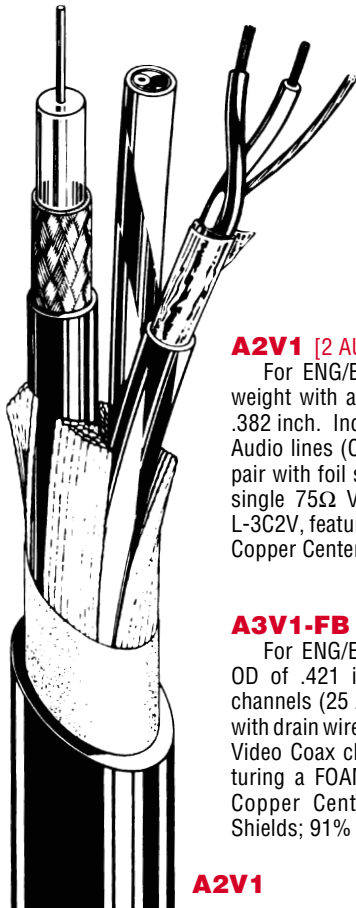
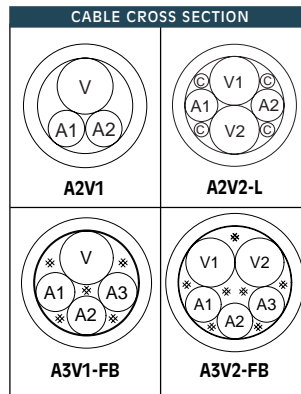

A2V1

A2V1 [2 AUDIO, 1 VIDEO]

For ENG/EFP/OB applications. Light-weight with a very thin profile OD of just .382 inch. Includes two 25 AWG balanced Audio lines (Canare L-2B2AT type twisted pair with foil shield and drain wire) plus a single 75Ω Video Coax channel (Canare L-3C2V, featuring a PE dielectric with Solid Copper Center Conductor).

A3V1-FB [3 AUDIO, 1 VIDEO]

For ENG/EFP/OB applications. Narrow OD of .421 inch. Three balanced Audio channels (25 AWG twisted pair, foil shield with drain wire) plus a single 75Ω Low Loss Video Coax channel (Canare L-3CFB, featuring a FOAM core dielectric with Solid Copper Center Conductor and double Shields; 91% Braid over 100% Foil).

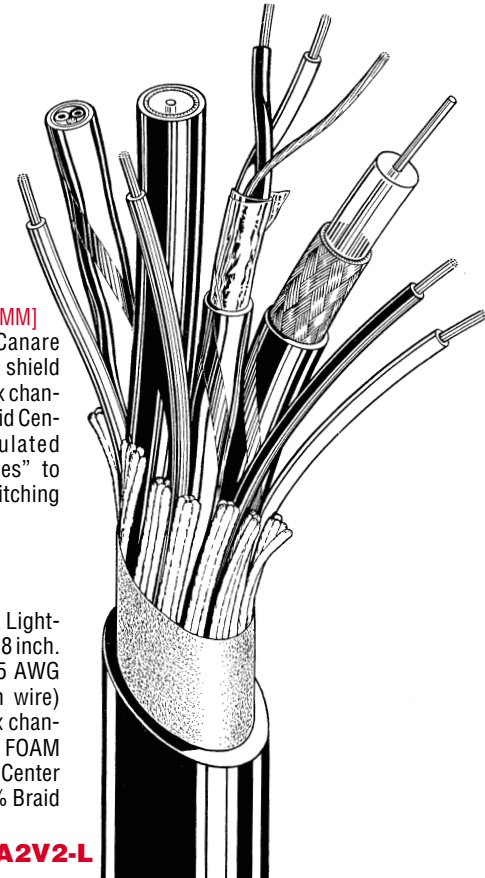

A2V2-L

A2V2-L [2 AUDIO, 2 VIDEO, 4 COMM]

Two balanced Audio lines (Canare L-2B2AT type twisted pair with foil shield and drain wire), two 75Ω Video coax channels (Canare L-3C2V, featuring a Solid Center Conductor) plus four insulated "intercom/remote control tally lines" to trigger camera, VCR or other switching functions. OD .433 inch.

A3V2-FB [3 AUDIO, 2 VIDEO]

For ENG/EFP/OB applications. Light-weight with a reduced OD of only .488 inch. Three balanced Audio channels (25 AWG twisted pair, foil shield with drain wire) plus two Low Loss 75Ω Video Coax channels (Canare L-3CFB, featuring a FOAM core dielectric with a Solid Copper Center Conductor and Double Shields; 91% Braid over 100% Foil).

AUDIO + VIDEO COMBO CABLE										
Model	Std. Lng.	Nom. O.D.	Weight Standard Length	Channel Unit	Cond. Strand Qty./mm	Insulation Type *	Shield Coverage	Channel Jacket	Channel Unit OD	Nom. Imp.
		Inch (mm)	lbs. (kgs)	Type x Qty	AWG	Color Code		PVC Color Code	in (mm)	
A2V1	328ft 100m	.382	24 11	V Coax 3C-2V x 1	1/0.5 #24	PE CLEAR	>97% AC Braid	BLK	.173 (4.4)	75Ω
	656ft 200m	9.7	48 22	A Twisted Pair 2B2-AT x 2	16/0.12 #25	IPE ORN, WHT	100% AL FOIL + TC Drain Wire	GRY/RED, GRY/BLU	.126 (3.2)	-
A2V2-L	328ft 100m	.433	35 16	V Coax 3C-2V x 2	1/0.5 #24	PE CLEAR	>97% AC Braid	BLK/YEL, BLK	.173 (4.4)	75Ω
	656ft 200m	11.0	70 32	A Twisted Pair 2B2-AT x 2	16/0.12 #25	IPE ORN, WHT	100% AL FOIL + TC Drain Wire	GRY/RED, GRY/BLU	.126 (3.2)	-
				C Control Line 0.2mm ² x 4	18/0.12 #24	PE RED, YEL, BLU, WHT	-	-	.051 (1.3)	-
A3V1-FB	656ft 200m	.421	53 24	V Coax 3C-FB x 1	1/0.65 #22	FOAM PE WHT	>91% TAC Braid 100% AL FOIL	YEL	.173 (4.4)	75Ω
		10.7		A Twisted Pair 2B2-AT x 3	16/0.12 #25	IPE ORN, WHT	100% AL FOIL + TC Drain Wire	GRY/YEL GRY/RED, GRY/BLU	.126 (3.2)	-
A3V2-FB	656ft 200m	.488	75 34	V Coax 3C-FB x 2	1/0.65 #22	FOAM PE WHT	>91% TAC Braid 100% AL FOIL	YEL, WHT	.173 (4.4)	75Ω
		12.4		A Twisted Pair 2B2-AT x 3	16/0.12 #25	IPE ORN, WHT	100% AL FOIL + TC Drain Wire	GRY/YEL GRY/RED, GRY/BLU	.126 (3.2)	-

* Dielectric Strength: 500 VAC/min. Insulation resistance: > 1000MΩ

75Ω VIDEO CHANNEL / CONNECTOR ASSEMBLY ITEMS						
Model	CANARE 75Ω Connectors			Cable Stripper	Crimp Tool	Die Set
	BNC	F	RCA			
3C-2V	BCP-C3B	FP-C3	RCAP-C3A	TS100E	TC-1	TCD-35CA
3C-FB	BCP-C3F	FP-C3F	RCAP-C3F	TS100E	TC-1	TCD-35CA

75Ω VIDEO CHANNEL / NOMINAL ATTENUATION					
Model	Length	10 MHz	30 MHz	275 MHz	800 MHz
3C-2V	dB/100 ft	1.3	2.2	6.7	11.5
	dB/100m	4.2	7.3	22.0	37.6
3C-FB	dB/100 ft	1.0	1.7	5.1	8.7
	dB/100m	3.2	5.5	16.8	28.6

APPLICATIONS

- AES/EBU DIGITAL AUDIO

FEATURES

Twisted Pairs with Braid or Foil Shield

Special PE FILLER RODS maintain constant 110Ω impedance

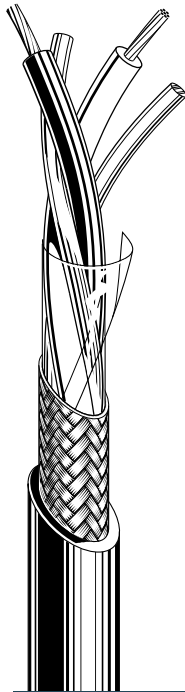

DA206

Large OD for longest cable runs. Robust construction makes this cable a good choice for all Digital Pro Audio field recording. Maximum recommended AES/EBU Length: 1,180ft (360meters). Jacket color: **BLUE**.

DA202

Mini version of DA206. 25 AWG conductors allow use with common IDC Punch Down Block, Digital Audio "110Ω Type" Patchbays. Integral Drain Wire for easy ground wiring. Maximum recommended AES/EBU Length: 590ft (180meters). Jacket color: **BLUE**.

DA202AT

Good choice for short cable runs. 25 AWG conductors suitable for all Rack Wiring applications, especially IDC Punch Down Block Digital Audio "110Ω Type" Patchbays. **Foil Shield** with Drain Wire allows easy strip, prep and ground wire termination. Maximum recommended AES/EBU Length: 426ft (130meters). Jacket color: **BLUE**.

DA202-P

Multi Channel version of DA202. Available in 2, 4 and 8 channel pairs. 25 AWG conductors allow use with Punch Down Block Audio Patchbays. Integral Drain Wire for easy ground wiring. Maximum recommended Length: 180meters. Overall Jacket color: **BLUE**

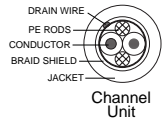

DA202-P CHANNEL UNIT COLOR CODE								
Channel No.	1	2	3	4	5	6	7	8
	RED	BLU	YEL	GRN	BRN	-	BLU/BLK	YEL/BLK

Model	Standard Length	Wgt. Stand. Length lbs. (kgs)	Nom. O.D. in. (mm)	Jacket Thickness PVC inch (mm)	Brittle Point °F (-C)	No. of Channels	Insul. Type * Thick. mil	Cond - AWG (Qty./mil) Cross Sec. Area	Shield Coverage	ELECTRICAL PERFORMANCE				Nominal Impedance
										Cond. D.C.R. Ω/1000ft (Ω/100m)	Shield D.C.R. Ω/1000ft (Ω/100m)	Nom. Cap. ** pF/ft (pF/m)	Nom. Cap. + pF/ft (pF/m)	
DA206	328ft	17	.287	.035	-56	1	IPE	AC-#20	>95% Braid	<10.1	<4.3	14.6	22.3	110Ω
	100m	8	7.3	0.9	-49		30.3	7/12.60		<3.3	<1.4	48	73	
	656ft	35												
DA202	328ft	8	.197	.034	-56	1	IPE	AC-#25	>95% Braid	<32.3	<6.8	-	-	110Ω
	100m	4	5.0	0.8	-49		16.9	7/7.09		<10.6	<2.2			
DA202AT	656ft	9	.157	.012	-56	1	IPE	AC-#25	100% AL Foil	<32.3	-	-	-	110Ω
DA202-2P	328ft	26	.421	.043	-56	2	IPE	AC-#25	>95% Braid	<32.3	<7.0	-	-	110Ω
	100m	12	10.7	1.1	-49									
DA202-4P	328ft	42	.496	.047	-56	4	16.9	7/7.09	>95% Braid	<32.3	<2.3	-	-	110Ω
	100m	19	12.6	1.2	-49									
DA202-8P	328ft	77	.646	.051	-56	8	16.9	7/7.09	>95% Braid	<32.3	<2.3	-	-	110Ω
	100m	35	16.4	1.3	-49									

*Dielectric Strength = 500V AC / 1min. Insulation resistance/3Mft = >1000MΩ. ** Capacitance between Conductors. + Capacitance between conductors to shield.

RS-422 CABLE



A2C3

Usable for RS-422 signals over short haul equipment interconnect distances. Data channel uses special Foam PE insulation for extra low signal loss.

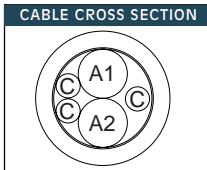

DATA CABLE



D403-AT

Star Quad style 64Ω data control cable; also usable for MIDI harness wiring. Four #22 Gauge Individually Color Coded Conductors. 100% Aluminum Foil shield with integral drain wire. Excellent pulling strength. Jacket color: SEPIA.

Model	Stand. Length	Nom. O.D. inch (mm)	Weight Standard Length lbs. (kgs)	Unit Channel	Qty. of Unit (Cond.)	Cond. Strand (Qty./mm) Cross Sec. Area (mm²)	AWG Size	Insulation Color Code	Shield Strand (mm/Qty.)	Insulation Type *	Channel Jacket	Jacket Nom. Thick. inch (mm)
A2C3	656ft 200m	.260 6.5	24 11	A Digital Data	2 (4)	7/.127 TAC 0.09	#28	A1-RED/WHT A2-BLU/WHT	0.1/37-47 Spiral	Foam Polyethylene	BLK, GRY	.032 0.8
D403AT	656ft 200m	.205 5.2	36 16	-	1 (4)	TAC 7/7.09	#22	RED, GRN, WHT, YEL	AL Foil 100%	IPE	Sepia	.205 5.2

* Dielectric Strength: 500 VAC/min. Insulation resistance: > 1000MΩ

SPECIAL FEATURES

- Durable long lasting black finish**
- Rugged winding handle**
- Roll-around removable casters**
- Snake cable hanger tabs**
- Exit flange port for snake ends**

Canare has developed a dependable and road worthy Cable Reel in three useful sizes that keeps cable stored neatly when not in use, yet allows quick deployment without tangles and twisting. A perfect way to facilitate transporting and laying cable. Protect your valuable cable investment with Canare Cable Reels.

3 Position Brake Lock System

All R-Series models include a 3-position brake lever:
 (Position 1) **FREE SPOOL**: cable will pull from reel with ease, this position is ideal for rewinding,
 (Position 2) **SOFT BRAKE**: cable can be pulled from the reel, but friction prevents excess spillage when cable is pulled quickly,
 (Position 3) **FULL LOCK**: used during transportation, the reel will not rotate, so cable will not spill.



Stackability
 All R300 series models have built in stacking tabs, so Cable Reels can be placed one on top of the other for secure transporting and storage.



R460S



R300S

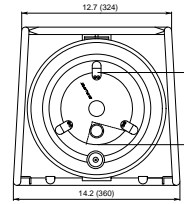

R300S

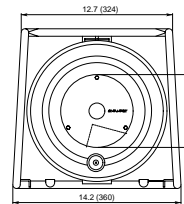
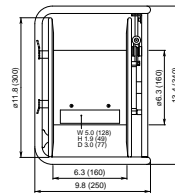

R300L

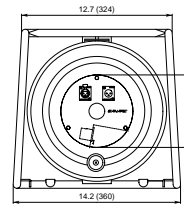
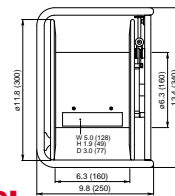

**R300CN
R300BN**

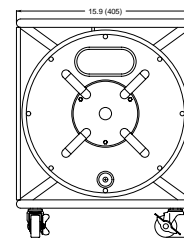
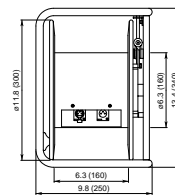

R380S

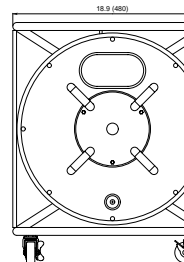
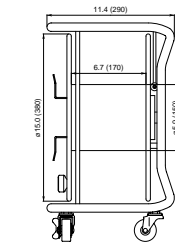

R460S

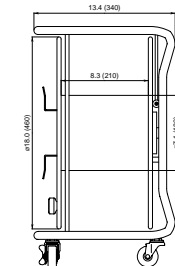

Tubular Steel Construction

Canare Cable Reels are constructed using tubular steel, with an "E" shaped brace design which makes them all extremely durable. All R-Series Reels use heavy duty permanently lubricated bearings which will perform as new even after years of hard road use.

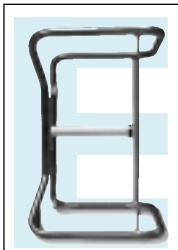

Special Connector Mounting Plates
 The R300L features a special User removable recessed Flange Door and Hub Plate for mounting BNC, F, RCA, or XLR Panel receptacles.

Please use the capacity chart and/or formula to determine length of a given cable that will fit on a specific reel. Formulas are based on loose wrap winding.

Calculation Formula

- R300 (S,L,CN,BN) $L = \frac{43}{D^2} \times 0.6$ (ft)
- R380S $L = \frac{93}{D^2} \times 0.6$ (ft)
- R380D $L = \frac{82}{D^2} \times 0.6$ (ft)
- R460S $L = \frac{172}{D^2} \times 0.6$ (ft)
- R460C $L = \frac{148}{D^2} \times 0.6$ (ft)

Formula Example:
 L-4E3-8P Cable O.D. is .603"
 $93 \div (.603 \times .603) \times .6 = 155$
 An R380S Cable Reel will hold approx. 155 feet of Canare L-4E3-8P Star Quad multichannel cable.

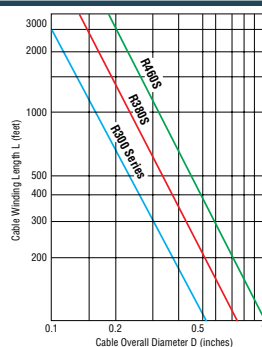

CABLE REEL SPECIFICATIONS							
Model	Size	Weight lbs.	Stackable	Casters	Connector Mounting	Cable Cut-Out	Hanger
R300S	SMALL	9.5	YES	NO	NO	YES	YES
R300L	SMALL	9.5	YES	NO	Hub & Flange	NO	NO
R300CN	SMALL	9.5	YES	NO	Parallel wired M & F XLR on Hub & Flange	NO	NO
R300BN	SMALL	9.5	YES	NO	75Ω BNC Jack 1ea.Hub & Flange	NO	NO
R380S	MED.	17.5	NO	YES	NO	YES	YES
R380D	MED.	17.5	NO	YES	Hub	NO	NO
R460S	LARGE	22.0	NO	YES	NO	YES	YES
R460C	LARGE	22.0	NO	YES	Hub	NO	NO

SNAKE TRUNK

Assembled with super flexible Canare L-4E3-P Star Quad multichannel audio cable, terminated at both ends with a MIL Spec JAE Cannon multipin connector. Dust caps with chain are included.



12 C30 E3

Number of Channels
8, 12, 16, 24
(32 Chan by special order)

Cable Type
E3 = Canare L-4E3-P Star Quad

- 8 & 12 Chnl NK27 Male to Female
- **DT12** & 16 Chnl FK37 Male to Female
- 24Chnl MS32 Female to Female

Cable Length
C10 = 10 meters (33ft)
C30 = 30 meters (98ft)
C50 = 50 meters (164ft)

FANTAIL

All versions are pre-assembled using Canare Star Quad L-4E microphone cable wired to JAE Cannon XLR-3 and multipin bayonet lock connectors. The overall fantail length is 5 feet and each channel is fitted with a large, sliding number collar ring for quick identification. Dust cap with chain included on multipin connector.



12 S2 N 1

Number of Channels
8, 12, 16, 24
(32 Channel by special order)

Multipin Type
1 = Female (entry)
2 = Male (exit)

- N = NK27 Pin (8, 12 Chnl)
- F = FK37 Pin (**DT12**, 16 Chnl)
- MS = MS32 54 Pin (24 Chnl)

XLR Configuration
S1 = Female (entry)
S2 = Male (exit)

CABLE REEL SNAKE

A unique and economical approach to multichannel cable storage and system component integrating. Assembled with a durable R-Series Canare Cable Reel, built-in flange-mounted junction box, hardwired Star Quad L-4E3-P Multichannel audio cable and multipin female Cannon connector. This modular design approach allows simple and secure mating with standard Canare Snakes, Junction Boxes, Pigtails or other Cable Reel Snakes.



16 R30 E3

Number of Channels
8, 12, 16, 24

Cable Length
R30 = 30 meters (98ft)
R50 = 50 meters (164ft)

Cable Type
E3 = Canare L-4E3-P Star Quad

- XLR Male & Female parallel wired
- 8 & 12 Chnl NK27 Female Multipin
- 16 Chnl FK37 Female Multipin
- 24 Chnl MS32 Female Multipin

JUNCTION BOX

Typically used at one or both ends of an audio snake. A Canare Junction Box will accept single microphone or line level XLR-3 type cables. The black anodized chassis is constructed from thick gage aluminum (0.16") which is light weight but exceptionally strong. All panel mount receptacles are secured to the chassis with screws (not pop rivets), should service ever be necessary. Skid pads and multipin dust caps with chain are included.

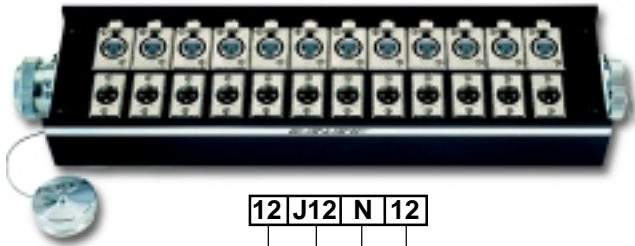

12 J12 N 12

Number of Channels
8, 12, 16, 24
(32 Channel by special order)

Multipin Type
1 = Female Only (Entry)
2 = Male Only (exit)
12 = Male & Female (feed through)

XLR Configuration
B1 = Female Only (inputs)
B2 = Male Only (returns)
J12 = Parallel Wired Male & Female

- N = NK27 Pin (8, 12 Chnl)
- F = FK37 Pin (**DT12**, 16 Chnl)
- MS = MS32 54 Pin (24 Chnl)

CONNECTORS

High quality ITT CANNON, JAE or DDK Multipin bayonet lock and XLR3 connectors are meticulously hand assembled and soldered with a minimum of unshielded wire leads.

Canare 8, 12, 16, 24, 32 channel Snakes are common shield wired via an integral shared return buss. This system is cost effective, saves space, and helps reduce noise and ground loops when used as a discreet audio snake arrangement. **DT12** Snakes are wired with individually isolated channel shields.

(ITT CANNON) XLR3 CONNECTORS TYPICAL FOR ALL CHANNELS



(JAE) FOR 8 & 12 CHANNELS



(JAE) FOR 16 CHANNELS & DT12



(DDK) FOR 24 CHANNELS



(DDK) FOR 32 CHANNELS









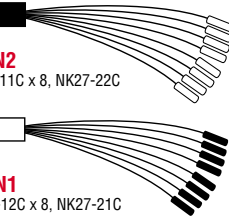
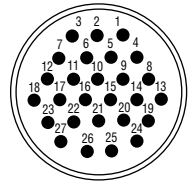

□ ○ Female ■ ● Male

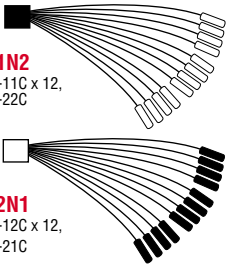
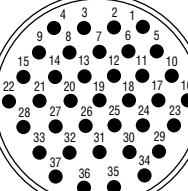
CHANNEL	CABLE REEL SNAKE		JUNCTION BOXES													
	L-4E3 Type Cable <i>D indicates R380 cable reel C indicates R460 cable reel</i>		Single XLR per channel	Parallel XLR per channel	Parallel XLR per channel MultiPin Feed Through											
8	<table border="1"> <thead> <tr> <th>Length</th> <th>Model</th> <th>Cable reel</th> <th>XLR3-32 x 8, XLR3-31 x 8, NK27-21C</th> </tr> </thead> <tbody> <tr> <td>30 m</td> <td>8R30E3</td> <td>D</td> <td></td> </tr> <tr> <td>50 m</td> <td>8R50E3</td> <td>D</td> <td></td> </tr> </tbody> </table>	Length	Model	Cable reel	XLR3-32 x 8, XLR3-31 x 8, NK27-21C	30 m	8R30E3	D		50 m	8R50E3	D		<p>8B1N2 XLR3-31 x 8, NK27-32S</p> <p>8B2N1 XLR3-32 x 8, NK27-31S</p>	<p>8J12N2 XLR3-31 x 8, XLR3-32 x 8, NK27-32S</p> <p>8J12N1 XLR3-31 x 8, XLR3-32 x 8, NK27-31S</p>	<p>8J12N12 XLR3-31 x 8, XLR3-32 x 8, NK27-31S, NK27-32S</p>
		Length	Model	Cable reel	XLR3-32 x 8, XLR3-31 x 8, NK27-21C											
30 m	8R30E3	D														
50 m	8R50E3	D														
12*	<table border="1"> <thead> <tr> <th>Length</th> <th>Model</th> <th>Cable reel</th> <th>XLR3-32 x 12, XLR3-31 x 12, NK27-21C</th> </tr> </thead> <tbody> <tr> <td>30 m</td> <td>12R30E3</td> <td>D</td> <td></td> </tr> <tr> <td>50 m</td> <td>12R50E3</td> <td>C</td> <td></td> </tr> </tbody> </table>	Length	Model	Cable reel	XLR3-32 x 12, XLR3-31 x 12, NK27-21C	30 m	12R30E3	D		50 m	12R50E3	C		<p>12B1N2 XLR3-31 x 12, NK27-32S</p> <p>12B2N1 XLR3-32 x 12, NK27-31S</p>	<p>12J12N2 XLR3-31 x 12, XLR3-32 x 12, NK27-32S</p> <p>12J12N1 XLR3-31 x 12, XLR3-32 x 12, NK27-31S</p>	<p>12J12N12 XLR3-31 x 12, XLR3-32 x 12, NK27-31S, NK27-32S</p>
		Length	Model	Cable reel	XLR3-32 x 12, XLR3-31 x 12, NK27-21C											
30 m	12R30E3	D														
50 m	12R50E3	C														
16	<table border="1"> <thead> <tr> <th>Length</th> <th>Model</th> <th>Cable reel</th> <th>XLR3-32 x 16, XLR3-31 x 16, FK37-21C</th> </tr> </thead> <tbody> <tr> <td>30 m</td> <td>16R30E3</td> <td>D</td> <td></td> </tr> <tr> <td>50 m</td> <td>16R50E3</td> <td>C</td> <td></td> </tr> </tbody> </table>	Length	Model	Cable reel	XLR3-32 x 16, XLR3-31 x 16, FK37-21C	30 m	16R30E3	D		50 m	16R50E3	C		<p>16B1F2 XLR3-31 x 16, FK37-32S</p> <p>16B2F1 XLR3-32 x 16, FK37-31S</p>	<p>16J12F2 XLR3-31 x 16, XLR3-32 x 16, FK37-32S</p> <p>16J12F1 XLR3-31 x 16, XLR3-32 x 16, FK37-31S</p>	<p>16J12F12 XLR3-31 x 16, XLR3-32 x 16, FK37-31S, FK37-32S</p>
		Length	Model	Cable reel	XLR3-32 x 16, XLR3-31 x 16, FK37-21C											
30 m	16R30E3	D														
50 m	16R50E3	C														
24	<table border="1"> <thead> <tr> <th>Length</th> <th>Model</th> <th>Cable reel</th> <th>XLR3-32 x 24, XLR3-31 x 24, MS3106B-32A-10S</th> </tr> </thead> <tbody> <tr> <td>30 m</td> <td>24R30E3</td> <td>C</td> <td></td> </tr> </tbody> </table>	Length	Model	Cable reel	XLR3-32 x 24, XLR3-31 x 24, MS3106B-32A-10S	30 m	24R30E3	C			<p>24B12MS XLR3-31 x 24 (on top), XLR3-32 x 24 (12 on each side), MS3102A-32A10P</p> <p>24B12MSW XLR3-31 x 24 (on top), XLR3-32 x 24 (12 on each side), MS3102A-32A10P x 2</p>					
		Length	Model	Cable reel	XLR3-32 x 24, XLR3-31 x 24, MS3106B-32A-10S											
30 m	24R30E3	C														
32	<p>ALL 32 CHANNEL SNAKE COMPONENTS ARE SPECIAL ORDER ITEMS</p>			<p>32B12MS XLR3-31 x 32, XLR3-32 x 32, MS3102A36-73P</p> <p>32B12MSW XLR3-31 x 32, XLR3-32 x 32, MS3102A36-73P x 2</p>												
			<p>32B12MWF11 XLR3-31 x 32, XLR3-32 x 32, MS3102A36-73P x 2, FK37-31S x 2</p>	<p>32B12MF11 XLR3-31 x 32, XLR3-32 x 32, MS3102A36-73P x 1, FK37-31S x 2</p>												

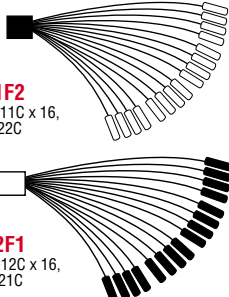
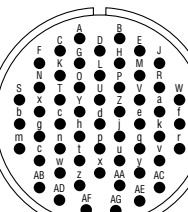
1 meter = 3.28 feet, 10 m = 33 ft, 30 m = 90 ft, 50 m = 164 ft

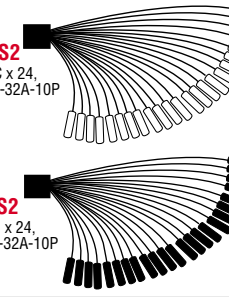
□ ○ Female ■ ● Male

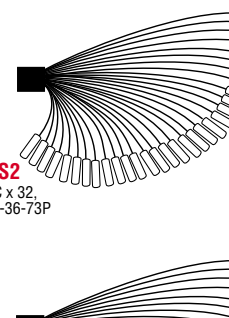
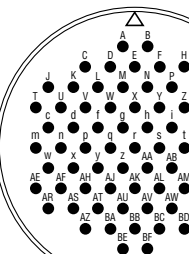
	SNAKE TRUNKS	FANTAILS	CONNECTORS	CHANNEL																																																																																																																																																																																					
	 <table border="1"> <thead> <tr> <th>Length</th> <th>Model</th> <th>Connectors</th> </tr> </thead> <tbody> <tr> <td colspan="3">L-4E3 Type Cable</td> </tr> <tr> <td>10 m</td> <td>8C10E3</td> <td rowspan="3">NK27-21C, NK27-22C</td> </tr> <tr> <td>30 m</td> <td>8C30E3</td> </tr> <tr> <td>50 m</td> <td>8C50E3</td> </tr> </tbody> </table>	Length	Model	Connectors	L-4E3 Type Cable			10 m	8C10E3	NK27-21C, NK27-22C	30 m	8C30E3	50 m	8C50E3	 <p>8S1N2 XLR3-11C x 8, NK27-22C</p> <p>8S2N1 XLR3-12C x 8, NK27-21C</p>	<p>For 8 & 12 Channels</p>  <p>NK-27</p> <p>DT12 CALL OR EMAIL CANARE FOR MECHANICAL & WIRING SPECIFICATIONS</p> <table border="1"> <thead> <tr> <th>CHAN No.</th> <th>L-4E3-P CHANNEL COLOR</th> <th>XLR3 CONNECTORS PIN 2</th> <th>PIN 3</th> <th>PIN 1</th> </tr> </thead> <tbody> <tr><td>1</td><td>RED</td><td>1 WHT</td><td>3 BLU</td><td></td></tr> <tr><td>2</td><td>BLU</td><td>4 WHT</td><td>5 BLU</td><td></td></tr> <tr><td>3</td><td>YEL</td><td>6 WHT</td><td>7 BLU</td><td></td></tr> <tr><td>4</td><td>GRN</td><td>8 WHT</td><td>9 BLU</td><td></td></tr> <tr><td>5</td><td>BRN</td><td>11 WHT</td><td>12 BLU</td><td>[10]</td></tr> <tr><td>6</td><td>-</td><td>13 WHT</td><td>14 BLU</td><td>COMMON SHIELD</td></tr> <tr><td>7</td><td>BLK/BLU</td><td>15 WHT</td><td>16 BLU</td><td></td></tr> <tr><td>8</td><td>BLK/YEL</td><td>17 WHT</td><td>18 BLU</td><td></td></tr> <tr><td>9</td><td>BLK/GRN</td><td>19 WHT</td><td>20 BLU</td><td></td></tr> <tr><td>10</td><td>BLK/BRN</td><td>22 WHT</td><td>23 BLU</td><td></td></tr> <tr><td>11</td><td>BLK</td><td>24 WHT</td><td>25 BLU</td><td></td></tr> <tr><td>12</td><td>ORN/BLU</td><td>26 WHT</td><td>27 BLU</td><td></td></tr> </tbody> </table> <p>↓ MULTI CONNECTOR PIN NO</p>	CHAN No.	L-4E3-P CHANNEL COLOR	XLR3 CONNECTORS PIN 2	PIN 3	PIN 1	1	RED	1 WHT	3 BLU		2	BLU	4 WHT	5 BLU		3	YEL	6 WHT	7 BLU		4	GRN	8 WHT	9 BLU		5	BRN	11 WHT	12 BLU	[10]	6	-	13 WHT	14 BLU	COMMON SHIELD	7	BLK/BLU	15 WHT	16 BLU		8	BLK/YEL	17 WHT	18 BLU		9	BLK/GRN	19 WHT	20 BLU		10	BLK/BRN	22 WHT	23 BLU		11	BLK	24 WHT	25 BLU		12	ORN/BLU	26 WHT	27 BLU		8																																																																																																							
Length	Model	Connectors																																																																																																																																																																																							
L-4E3 Type Cable																																																																																																																																																																																									
10 m	8C10E3	NK27-21C, NK27-22C																																																																																																																																																																																							
30 m	8C30E3																																																																																																																																																																																								
50 m	8C50E3																																																																																																																																																																																								
CHAN No.	L-4E3-P CHANNEL COLOR	XLR3 CONNECTORS PIN 2	PIN 3	PIN 1																																																																																																																																																																																					
1	RED	1 WHT	3 BLU																																																																																																																																																																																						
2	BLU	4 WHT	5 BLU																																																																																																																																																																																						
3	YEL	6 WHT	7 BLU																																																																																																																																																																																						
4	GRN	8 WHT	9 BLU																																																																																																																																																																																						
5	BRN	11 WHT	12 BLU	[10]																																																																																																																																																																																					
6	-	13 WHT	14 BLU	COMMON SHIELD																																																																																																																																																																																					
7	BLK/BLU	15 WHT	16 BLU																																																																																																																																																																																						
8	BLK/YEL	17 WHT	18 BLU																																																																																																																																																																																						
9	BLK/GRN	19 WHT	20 BLU																																																																																																																																																																																						
10	BLK/BRN	22 WHT	23 BLU																																																																																																																																																																																						
11	BLK	24 WHT	25 BLU																																																																																																																																																																																						
12	ORN/BLU	26 WHT	27 BLU																																																																																																																																																																																						
	 <table border="1"> <thead> <tr> <th>Length</th> <th>Model</th> <th>Connectors</th> </tr> </thead> <tbody> <tr> <td colspan="3">L-4E3 Type Cable</td> </tr> <tr> <td>10 m</td> <td>12C10E3</td> <td rowspan="3">NK27-21C, NK27-22C</td> </tr> <tr> <td>30 m</td> <td>12C30E3</td> </tr> <tr> <td>50 m</td> <td>12C50E3</td> </tr> </tbody> </table>	Length	Model	Connectors	L-4E3 Type Cable			10 m	12C10E3	NK27-21C, NK27-22C	30 m	12C30E3	50 m	12C50E3	 <p>12S1N2 XLR3-11C x 12, NK27-22C</p> <p>12S2N1 XLR3-12C x 12, NK27-21C</p>	<p>For 16 Channels</p>  <p>FK-37</p> <table border="1"> <thead> <tr> <th>CHAN No.</th> <th>L-4E3-P CHANNEL COLOR</th> <th>XLR3 CONNECTORS PIN 2</th> <th>PIN 3</th> <th>PIN 1</th> </tr> </thead> <tbody> <tr><td>1</td><td>RED</td><td>1 WHT</td><td>2 BLU</td><td></td></tr> <tr><td>2</td><td>BLU</td><td>3 WHT</td><td>4 BLU</td><td></td></tr> <tr><td>3</td><td>YEL</td><td>5 WHT</td><td>6 BLU</td><td></td></tr> <tr><td>4</td><td>GRN</td><td>8 WHT</td><td>9 BLU</td><td></td></tr> <tr><td>5</td><td>BRN</td><td>10 WHT</td><td>11 BLU</td><td></td></tr> <tr><td>6</td><td>-</td><td>12 WHT</td><td>13 BLU</td><td></td></tr> <tr><td>7</td><td>BLK/BLU</td><td>14 WHT</td><td>15 BLU</td><td>[13]</td></tr> <tr><td>8</td><td>BLK/YEL</td><td>16 WHT</td><td>17 BLU</td><td>COMMON SHIELD</td></tr> <tr><td>9</td><td>BLK/GRN</td><td>21 WHT</td><td>22 BLU</td><td></td></tr> <tr><td>10</td><td>BLK/BRN</td><td>23 WHT</td><td>24 BLU</td><td></td></tr> <tr><td>11</td><td>BLK</td><td>25 WHT</td><td>26 BLU</td><td></td></tr> <tr><td>12</td><td>ORN/BLU</td><td>27 WHT</td><td>28 BLU</td><td></td></tr> <tr><td>13</td><td>ORN/YEL</td><td>29 WHT</td><td>30 BLU</td><td></td></tr> <tr><td>14</td><td>ORN/GRN</td><td>32 WHT</td><td>33 BLU</td><td></td></tr> <tr><td>15</td><td>ORN/BRN</td><td>34 WHT</td><td>36 BLU</td><td></td></tr> <tr><td>16</td><td>ORN</td><td>36 WHT</td><td>37 BLU</td><td></td></tr> </tbody> </table> <p>↓ MULTI CONNECTOR PIN NO</p>	CHAN No.	L-4E3-P CHANNEL COLOR	XLR3 CONNECTORS PIN 2	PIN 3	PIN 1	1	RED	1 WHT	2 BLU		2	BLU	3 WHT	4 BLU		3	YEL	5 WHT	6 BLU		4	GRN	8 WHT	9 BLU		5	BRN	10 WHT	11 BLU		6	-	12 WHT	13 BLU		7	BLK/BLU	14 WHT	15 BLU	[13]	8	BLK/YEL	16 WHT	17 BLU	COMMON SHIELD	9	BLK/GRN	21 WHT	22 BLU		10	BLK/BRN	23 WHT	24 BLU		11	BLK	25 WHT	26 BLU		12	ORN/BLU	27 WHT	28 BLU		13	ORN/YEL	29 WHT	30 BLU		14	ORN/GRN	32 WHT	33 BLU		15	ORN/BRN	34 WHT	36 BLU		16	ORN	36 WHT	37 BLU		12*																																																																																			
Length	Model	Connectors																																																																																																																																																																																							
L-4E3 Type Cable																																																																																																																																																																																									
10 m	12C10E3	NK27-21C, NK27-22C																																																																																																																																																																																							
30 m	12C30E3																																																																																																																																																																																								
50 m	12C50E3																																																																																																																																																																																								
CHAN No.	L-4E3-P CHANNEL COLOR	XLR3 CONNECTORS PIN 2	PIN 3	PIN 1																																																																																																																																																																																					
1	RED	1 WHT	2 BLU																																																																																																																																																																																						
2	BLU	3 WHT	4 BLU																																																																																																																																																																																						
3	YEL	5 WHT	6 BLU																																																																																																																																																																																						
4	GRN	8 WHT	9 BLU																																																																																																																																																																																						
5	BRN	10 WHT	11 BLU																																																																																																																																																																																						
6	-	12 WHT	13 BLU																																																																																																																																																																																						
7	BLK/BLU	14 WHT	15 BLU	[13]																																																																																																																																																																																					
8	BLK/YEL	16 WHT	17 BLU	COMMON SHIELD																																																																																																																																																																																					
9	BLK/GRN	21 WHT	22 BLU																																																																																																																																																																																						
10	BLK/BRN	23 WHT	24 BLU																																																																																																																																																																																						
11	BLK	25 WHT	26 BLU																																																																																																																																																																																						
12	ORN/BLU	27 WHT	28 BLU																																																																																																																																																																																						
13	ORN/YEL	29 WHT	30 BLU																																																																																																																																																																																						
14	ORN/GRN	32 WHT	33 BLU																																																																																																																																																																																						
15	ORN/BRN	34 WHT	36 BLU																																																																																																																																																																																						
16	ORN	36 WHT	37 BLU																																																																																																																																																																																						
	 <table border="1"> <thead> <tr> <th>Length</th> <th>Model</th> <th>Connectors</th> </tr> </thead> <tbody> <tr> <td colspan="3">L-4E3 Type Cable</td> </tr> <tr> <td>10 m</td> <td>16C10E3</td> <td rowspan="3">FK37-21C, FK37-22C</td> </tr> <tr> <td>30 m</td> <td>16C30E3</td> </tr> <tr> <td>50 m</td> <td>16C50E3</td> </tr> </tbody> </table>	Length	Model	Connectors	L-4E3 Type Cable			10 m	16C10E3	FK37-21C, FK37-22C	30 m	16C30E3	50 m	16C50E3	 <p>16S1F2 XLR3-11C x 16, FK37-22C</p> <p>16S2F1 XLR3-12C x 16, FK37-21C</p>	<p>For 24 Channels</p>  <p>32A10</p> <table border="1"> <thead> <tr> <th>CHAN No.</th> <th>L-4E3-P CHANNEL COLOR</th> <th>XLR3 CONNECTORS PIN 2</th> <th>PIN 3</th> <th>PIN 1</th> </tr> </thead> <tbody> <tr><td>1</td><td>RED</td><td>A WHT</td><td>B BLU</td><td></td></tr> <tr><td>2</td><td>BLU</td><td>C WHT</td><td>D BLU</td><td></td></tr> <tr><td>3</td><td>YEL</td><td>F WHT</td><td>G BLU</td><td></td></tr> <tr><td>4</td><td>GRN</td><td>H WHT</td><td>J BLU</td><td></td></tr> <tr><td>5</td><td>BRN</td><td>K WHT</td><td>L BLU</td><td></td></tr> <tr><td>6</td><td>-</td><td>N WHT</td><td>O BLU</td><td></td></tr> <tr><td>7</td><td>BLK/BLU</td><td>P WHT</td><td>R BLU</td><td></td></tr> <tr><td>8</td><td>BLK/YEL</td><td>S WHT</td><td>T BLU</td><td></td></tr> <tr><td>9</td><td>BLK/GRN</td><td>U WHT</td><td>V BLU</td><td></td></tr> <tr><td>10</td><td>BLK/BRN</td><td>X WHT</td><td>Y BLU</td><td></td></tr> <tr><td>11</td><td>BLK</td><td>Z WHT</td><td>a BLU</td><td>[E]</td></tr> <tr><td>12</td><td>ORN/BLU</td><td>b WHT</td><td>c BLU</td><td>COMMON SHIELD</td></tr> <tr><td>13</td><td>ORN/YEL</td><td>d WHT</td><td>e BLU</td><td></td></tr> <tr><td>14</td><td>ORN/GRN</td><td>g WHT</td><td>h BLU</td><td></td></tr> <tr><td>15</td><td>ORN/BRN</td><td>i WHT</td><td>k BLU</td><td></td></tr> <tr><td>16</td><td>ORN</td><td>m WHT</td><td>n BLU</td><td></td></tr> <tr><td>17</td><td>PNK/BLU</td><td>o WHT</td><td>q BLU</td><td></td></tr> <tr><td>18</td><td>PNK/YEL</td><td>s WHT</td><td>t BLU</td><td></td></tr> <tr><td>19</td><td>PNK/GRN</td><td>u WHT</td><td>v BLU</td><td></td></tr> <tr><td>20</td><td>PNK/BRN</td><td>w WHT</td><td>x BLU</td><td></td></tr> <tr><td>21</td><td>PNK</td><td>AB WHT</td><td>Z BLU</td><td></td></tr> <tr><td>22</td><td>WHT/BLU</td><td>AA WHT</td><td>AC BLU</td><td></td></tr> <tr><td>23</td><td>WHT/YEL</td><td>AD WHT</td><td>AF BLU</td><td></td></tr> <tr><td>24</td><td>WHT/GRN</td><td>AG WHT</td><td>AE BLU</td><td></td></tr> </tbody> </table> <p>↓ MULTI CONNECTOR PIN NO</p>	CHAN No.	L-4E3-P CHANNEL COLOR	XLR3 CONNECTORS PIN 2	PIN 3	PIN 1	1	RED	A WHT	B BLU		2	BLU	C WHT	D BLU		3	YEL	F WHT	G BLU		4	GRN	H WHT	J BLU		5	BRN	K WHT	L BLU		6	-	N WHT	O BLU		7	BLK/BLU	P WHT	R BLU		8	BLK/YEL	S WHT	T BLU		9	BLK/GRN	U WHT	V BLU		10	BLK/BRN	X WHT	Y BLU		11	BLK	Z WHT	a BLU	[E]	12	ORN/BLU	b WHT	c BLU	COMMON SHIELD	13	ORN/YEL	d WHT	e BLU		14	ORN/GRN	g WHT	h BLU		15	ORN/BRN	i WHT	k BLU		16	ORN	m WHT	n BLU		17	PNK/BLU	o WHT	q BLU		18	PNK/YEL	s WHT	t BLU		19	PNK/GRN	u WHT	v BLU		20	PNK/BRN	w WHT	x BLU		21	PNK	AB WHT	Z BLU		22	WHT/BLU	AA WHT	AC BLU		23	WHT/YEL	AD WHT	AF BLU		24	WHT/GRN	AG WHT	AE BLU		16																																											
Length	Model	Connectors																																																																																																																																																																																							
L-4E3 Type Cable																																																																																																																																																																																									
10 m	16C10E3	FK37-21C, FK37-22C																																																																																																																																																																																							
30 m	16C30E3																																																																																																																																																																																								
50 m	16C50E3																																																																																																																																																																																								
CHAN No.	L-4E3-P CHANNEL COLOR	XLR3 CONNECTORS PIN 2	PIN 3	PIN 1																																																																																																																																																																																					
1	RED	A WHT	B BLU																																																																																																																																																																																						
2	BLU	C WHT	D BLU																																																																																																																																																																																						
3	YEL	F WHT	G BLU																																																																																																																																																																																						
4	GRN	H WHT	J BLU																																																																																																																																																																																						
5	BRN	K WHT	L BLU																																																																																																																																																																																						
6	-	N WHT	O BLU																																																																																																																																																																																						
7	BLK/BLU	P WHT	R BLU																																																																																																																																																																																						
8	BLK/YEL	S WHT	T BLU																																																																																																																																																																																						
9	BLK/GRN	U WHT	V BLU																																																																																																																																																																																						
10	BLK/BRN	X WHT	Y BLU																																																																																																																																																																																						
11	BLK	Z WHT	a BLU	[E]																																																																																																																																																																																					
12	ORN/BLU	b WHT	c BLU	COMMON SHIELD																																																																																																																																																																																					
13	ORN/YEL	d WHT	e BLU																																																																																																																																																																																						
14	ORN/GRN	g WHT	h BLU																																																																																																																																																																																						
15	ORN/BRN	i WHT	k BLU																																																																																																																																																																																						
16	ORN	m WHT	n BLU																																																																																																																																																																																						
17	PNK/BLU	o WHT	q BLU																																																																																																																																																																																						
18	PNK/YEL	s WHT	t BLU																																																																																																																																																																																						
19	PNK/GRN	u WHT	v BLU																																																																																																																																																																																						
20	PNK/BRN	w WHT	x BLU																																																																																																																																																																																						
21	PNK	AB WHT	Z BLU																																																																																																																																																																																						
22	WHT/BLU	AA WHT	AC BLU																																																																																																																																																																																						
23	WHT/YEL	AD WHT	AF BLU																																																																																																																																																																																						
24	WHT/GRN	AG WHT	AE BLU																																																																																																																																																																																						
	 <table border="1"> <thead> <tr> <th>Length</th> <th>Model</th> <th>Connectors</th> </tr> </thead> <tbody> <tr> <td colspan="3">L-4E3 Type Cable</td> </tr> <tr> <td>1 m</td> <td>24C01E3M22</td> <td rowspan="2">MS3101A-32A-10P Connecting cable (both ends)</td> </tr> <tr> <td>10 m</td> <td>24C10E3</td> </tr> <tr> <td>30 m</td> <td>24C30E3</td> <td rowspan="2">MS3106B-32A-10S (both ends)</td> </tr> <tr> <td>50 m</td> <td>24C50E3</td> </tr> </tbody> </table>	Length	Model	Connectors	L-4E3 Type Cable			1 m	24C01E3M22	MS3101A-32A-10P Connecting cable (both ends)	10 m	24C10E3	30 m	24C30E3	MS3106B-32A-10S (both ends)	50 m	24C50E3	 <p>24S1MS2 XLR3-11C x 24, MS3101A-32A-10P</p> <p>24S2MS2 XLR3-12C x 24, MS3101A-32A-10P</p>	<p>For 32 Channels</p>  <table border="1"> <thead> <tr> <th>CHAN No.</th> <th>MR202-32AT CHANNEL COLOR</th> <th>XLR3 CONNECTORS PIN 2</th> <th>PIN 3</th> <th>PIN 1</th> </tr> </thead> <tbody> <tr><td>1</td><td>BLK/BRN</td><td>A CLR</td><td>B BRN</td><td></td></tr> <tr><td>2</td><td>BLK/RED</td><td>C CLR</td><td>D RED</td><td></td></tr> <tr><td>3</td><td>BLK/ORN</td><td>F CLR</td><td>H ORN</td><td></td></tr> <tr><td>4</td><td>BLK/YEL</td><td>J CLR</td><td>K YEL</td><td></td></tr> <tr><td>5</td><td>BLK/GRN</td><td>L CLR</td><td>M GRN</td><td></td></tr> <tr><td>6</td><td>BLK/BLU</td><td>N CLR</td><td>P BLU</td><td></td></tr> <tr><td>7</td><td>BLK/PPL</td><td>R CLR</td><td>S PPL</td><td></td></tr> <tr><td>8</td><td>BLK/GRY</td><td>T CLR</td><td>U GRY</td><td></td></tr> <tr><td>9</td><td>BLK/WHT</td><td>V CLR</td><td>W WHT</td><td></td></tr> <tr><td>10</td><td>BRN/BLK</td><td>Y CLR</td><td>Z BLK</td><td></td></tr> <tr><td>11</td><td>BRN</td><td>a CLR</td><td>b BRN</td><td></td></tr> <tr><td>12</td><td>BRN/RED</td><td>c CLR</td><td>d RED</td><td></td></tr> <tr><td>13</td><td>BRN/ORN</td><td>f CLR</td><td>g ORN</td><td></td></tr> <tr><td>14</td><td>BRN/YEL</td><td>h CLR</td><td>i YEL</td><td></td></tr> <tr><td>15</td><td>BRN/GRN</td><td>l CLR</td><td>k GRN</td><td>[E]</td></tr> <tr><td>16</td><td>BRN/BLU</td><td>m CLR</td><td>n BLU</td><td>[F][G][H]</td></tr> <tr><td>17</td><td>BRN/PPL</td><td>u CLR</td><td>v PPL</td><td>[AK][BB]</td></tr> <tr><td>18</td><td>BRN/GRY</td><td>w CLR</td><td>x GRY</td><td>COMMON SHIELD</td></tr> <tr><td>19</td><td>BRN/WHT</td><td>y CLR</td><td>z WHT</td><td></td></tr> <tr><td>20</td><td>RED/BLK</td><td>AA CLR</td><td>AB BLK</td><td></td></tr> <tr><td>21</td><td>RED/BRN</td><td>AC CLR</td><td>AD BRN</td><td></td></tr> <tr><td>22</td><td>RED</td><td>AE CLR</td><td>AF RED</td><td></td></tr> <tr><td>23</td><td>RED/ORN</td><td>AH CLR</td><td>AJ ORN</td><td></td></tr> <tr><td>24</td><td>RED/YEL</td><td>AL CLR</td><td>AM YEL</td><td></td></tr> <tr><td>25</td><td>RED/GRN</td><td>AN CLR</td><td>AP GRN</td><td></td></tr> <tr><td>26</td><td>RED/BLU</td><td>AR CLR</td><td>AS BLU</td><td></td></tr> <tr><td>27</td><td>RED/PPL</td><td>AT CLR</td><td>AU PPL</td><td></td></tr> <tr><td>28</td><td>RED/GRY</td><td>AV CLR</td><td>AW GRY</td><td></td></tr> <tr><td>29</td><td>RED/WHT</td><td>AX CLR</td><td>AY WHT</td><td></td></tr> <tr><td>30</td><td>ORN/BLK</td><td>AZ CLR</td><td>BA BLK</td><td></td></tr> <tr><td>31</td><td>ORN/BRN</td><td>BC CLR</td><td>BD BRN</td><td></td></tr> <tr><td>32</td><td>ORN/RED</td><td>BE CLR</td><td>BF RED</td><td></td></tr> </tbody> </table> <p>↓ MULTI CONNECTOR PIN NO</p>	CHAN No.	MR202-32AT CHANNEL COLOR	XLR3 CONNECTORS PIN 2	PIN 3	PIN 1	1	BLK/BRN	A CLR	B BRN		2	BLK/RED	C CLR	D RED		3	BLK/ORN	F CLR	H ORN		4	BLK/YEL	J CLR	K YEL		5	BLK/GRN	L CLR	M GRN		6	BLK/BLU	N CLR	P BLU		7	BLK/PPL	R CLR	S PPL		8	BLK/GRY	T CLR	U GRY		9	BLK/WHT	V CLR	W WHT		10	BRN/BLK	Y CLR	Z BLK		11	BRN	a CLR	b BRN		12	BRN/RED	c CLR	d RED		13	BRN/ORN	f CLR	g ORN		14	BRN/YEL	h CLR	i YEL		15	BRN/GRN	l CLR	k GRN	[E]	16	BRN/BLU	m CLR	n BLU	[F][G][H]	17	BRN/PPL	u CLR	v PPL	[AK][BB]	18	BRN/GRY	w CLR	x GRY	COMMON SHIELD	19	BRN/WHT	y CLR	z WHT		20	RED/BLK	AA CLR	AB BLK		21	RED/BRN	AC CLR	AD BRN		22	RED	AE CLR	AF RED		23	RED/ORN	AH CLR	AJ ORN		24	RED/YEL	AL CLR	AM YEL		25	RED/GRN	AN CLR	AP GRN		26	RED/BLU	AR CLR	AS BLU		27	RED/PPL	AT CLR	AU PPL		28	RED/GRY	AV CLR	AW GRY		29	RED/WHT	AX CLR	AY WHT		30	ORN/BLK	AZ CLR	BA BLK		31	ORN/BRN	BC CLR	BD BRN		32	ORN/RED	BE CLR	BF RED		24
Length	Model	Connectors																																																																																																																																																																																							
L-4E3 Type Cable																																																																																																																																																																																									
1 m	24C01E3M22	MS3101A-32A-10P Connecting cable (both ends)																																																																																																																																																																																							
10 m	24C10E3																																																																																																																																																																																								
30 m	24C30E3	MS3106B-32A-10S (both ends)																																																																																																																																																																																							
50 m	24C50E3																																																																																																																																																																																								
CHAN No.	MR202-32AT CHANNEL COLOR	XLR3 CONNECTORS PIN 2	PIN 3	PIN 1																																																																																																																																																																																					
1	BLK/BRN	A CLR	B BRN																																																																																																																																																																																						
2	BLK/RED	C CLR	D RED																																																																																																																																																																																						
3	BLK/ORN	F CLR	H ORN																																																																																																																																																																																						
4	BLK/YEL	J CLR	K YEL																																																																																																																																																																																						
5	BLK/GRN	L CLR	M GRN																																																																																																																																																																																						
6	BLK/BLU	N CLR	P BLU																																																																																																																																																																																						
7	BLK/PPL	R CLR	S PPL																																																																																																																																																																																						
8	BLK/GRY	T CLR	U GRY																																																																																																																																																																																						
9	BLK/WHT	V CLR	W WHT																																																																																																																																																																																						
10	BRN/BLK	Y CLR	Z BLK																																																																																																																																																																																						
11	BRN	a CLR	b BRN																																																																																																																																																																																						
12	BRN/RED	c CLR	d RED																																																																																																																																																																																						
13	BRN/ORN	f CLR	g ORN																																																																																																																																																																																						
14	BRN/YEL	h CLR	i YEL																																																																																																																																																																																						
15	BRN/GRN	l CLR	k GRN	[E]																																																																																																																																																																																					
16	BRN/BLU	m CLR	n BLU	[F][G][H]																																																																																																																																																																																					
17	BRN/PPL	u CLR	v PPL	[AK][BB]																																																																																																																																																																																					
18	BRN/GRY	w CLR	x GRY	COMMON SHIELD																																																																																																																																																																																					
19	BRN/WHT	y CLR	z WHT																																																																																																																																																																																						
20	RED/BLK	AA CLR	AB BLK																																																																																																																																																																																						
21	RED/BRN	AC CLR	AD BRN																																																																																																																																																																																						
22	RED	AE CLR	AF RED																																																																																																																																																																																						
23	RED/ORN	AH CLR	AJ ORN																																																																																																																																																																																						
24	RED/YEL	AL CLR	AM YEL																																																																																																																																																																																						
25	RED/GRN	AN CLR	AP GRN																																																																																																																																																																																						
26	RED/BLU	AR CLR	AS BLU																																																																																																																																																																																						
27	RED/PPL	AT CLR	AU PPL																																																																																																																																																																																						
28	RED/GRY	AV CLR	AW GRY																																																																																																																																																																																						
29	RED/WHT	AX CLR	AY WHT																																																																																																																																																																																						
30	ORN/BLK	AZ CLR	BA BLK																																																																																																																																																																																						
31	ORN/BRN	BC CLR	BD BRN																																																																																																																																																																																						
32	ORN/RED	BE CLR	BF RED																																																																																																																																																																																						
	 <table border="1"> <thead> <tr> <th>Length</th> <th>Model</th> <th>Connectors</th> </tr> </thead> <tbody> <tr> <td colspan="3">MR202-AT Type Cable</td> </tr> <tr> <td>1 m</td> <td>32C01MR2M22</td> <td rowspan="2">MS3101A-36-73P Connecting cable (both ends)</td> </tr> <tr> <td>10 m</td> <td>32C10MR2</td> </tr> <tr> <td>30 m</td> <td>32C30MR2</td> <td rowspan="2">MS3106B-36-73S (both ends)</td> </tr> <tr> <td>50 m</td> <td>32C50MR2</td> </tr> </tbody> </table>	Length	Model	Connectors	MR202-AT Type Cable			1 m	32C01MR2M22	MS3101A-36-73P Connecting cable (both ends)	10 m	32C10MR2	30 m	32C30MR2	MS3106B-36-73S (both ends)	50 m	32C50MR2	 <p>32S1MS2 XLR3-11C x 32, MS3101A-36-73P</p> <p>32S2MS2 XLR3-12C x 32, MS3101A-36-73P</p>	<p>For 32 Channels</p>  <p>36-73</p>	32																																																																																																																																																																					
Length	Model	Connectors																																																																																																																																																																																							
MR202-AT Type Cable																																																																																																																																																																																									
1 m	32C01MR2M22	MS3101A-36-73P Connecting cable (both ends)																																																																																																																																																																																							
10 m	32C10MR2																																																																																																																																																																																								
30 m	32C30MR2	MS3106B-36-73S (both ends)																																																																																																																																																																																							
50 m	32C50MR2																																																																																																																																																																																								

APPLICATIONS

- ANALOG & DIGITAL VIDEO
- RGB(S, H/V) COMPONENT VIDEO
- VIDEO WALLS
- HI-RES PROJECTORS
- CG / CAD WORKSTATIONS

VS • 75Ω COMPONENT VIDEO FANTAILS

Canare 75Ω VS component cable is available in a variety of pre-cut lengths terminated with our true 75Ω BNC crimp plugs. All assemblies are precisely timed with less than 2.2 nanoseconds between adjacent video channels. Canare VS fantails offer extra wide video bandwidth performance because cable and connectors are 75Ω impedance matched.

Custom assembly configurations can be special ordered using any of Canare's other V-Series models: **V-1.5C, V-3C, V-5C, V-3CFB, V-4CFB** and **V-5CFB** multichannel video snake series in a variety of metric lengths.

FEATURES

- Canare true 75Ω BCP-C Crimp Plugs
- < 2.2 nanoseconds channel delay
- Super Flexible, easy payout & wrap-up
- Bundled Cables keep work site neat
- 100% Test and Quality Controlled
- Excellent Connector Pull Strength
- Color Matching BNC Strain Relief Boots
- Jacket Protection Sleeve at Fan Breakout
- Wide Selection of V-Series Cable Types

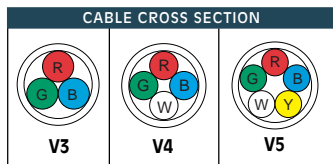

CABLE NOMINAL O.D.		
Model	inch	mm
V3-1.5C	.291	7.4
V4-1.5C	.331	8.4
V5-1.5C	.362	9.2
V3-3C	.453	11.5
V4-3C	.512	13.0
V5-3C	.559	14.2
V3-5C	.611	15.5
V4-5C	.674	17.1
V5-5C	.756	19.2
V3-3CFB	.453	11.5
V4-3CFB	.512	13.0
V5-3CFB	.559	14.2
V3-4CFB	.508	12.9
V4-4CFB	.567	14.4
V5-4CFB	.634	16.1
V3-5CFB	.673	17.1
V4-5CFB	.740	18.8
V5-5CFB	.831	21.1

STANDARD STOCK • VS 75Ω VIDEO SNAKES					
Model	Lng.	Number of Channels	75Ω Cable	75Ω BNC Plugs	Color Boot
3VS03-3C	9.8ft, 3m	3	V3-3C	BCP-C3B	CB03
3VS05-3C	16.4ft, 5m	RED, GRN, BLU	V3-3C		
4VS03-3C	9.8ft, 3m	4	V4-3C		
4VS05-3C	16.4ft, 5m	RED, GRN, BLUE, WHT	V4-3C		
5VS03-3C	9.8ft, 3m	5	V5-3C		
5VS05-3C	16.4ft, 5m	RED, GRN, BLUE, WHT, YEL	V5-3C		

NOMINAL ATTENUATION VALUE										
		1MHz	10MHz	50MHz	100MHz	200MHz	400MHz	700MHz	900MHz	1GHz
V-1.5C	dB/100 ft	0.9	2.9	6.5	9.3	13.1	18.5	24.5	27.8	29.3
	dB/100m	3.0	9.6	21.5	30.4	42.9	60.7	80.3	91.1	96.0
V-3C	dB/100 ft	0.5	1.5	3.2	4.7	6.7	9.4	12.5	14.2	14.9
	dB/100m	1.5	4.9	10.4	15.5	21.9	31.0	41.0	46.5	49.0
V-5C	dB/100 ft	0.3	1.0	2.4	3.3	4.6	6.6	8.6	9.8	10.4
	dB/100m	1.1	3.4	7.8	10.8	14.7	21.5	28.4	32.3	34.0
V-3CFB	dB/100 ft	0.3	1.0	2.5	3.3	4.5	6.5	8.8	10.1	10.6
	dB/100m	1.1	3.2	8.0	10.7	14.7	21.3	28.9	33.0	34.8
V-4CFB	dB/100 ft	0.3	0.9	2.0	2.7	3.8	5.4	7.3	8.4	8.9
	dB/100m	1.0	2.9	6.7	8.9	12.4	17.7	24.0	27.6	29.3
V-5CFB	dB/100 ft	0.3	0.7	1.6	2.2	3.0	4.3	6.0	6.8	7.2
	dB/100m	0.8	2.2	5.3	7.1	9.9	14.2	19.5	22.2	23.7

Custom Model Selection Guide

4 VS 05 - 3C

Number of Channels
3, 4, 5

V-Series Cable Type
1.5C
3C
5C
3CFB
4CFB
5CFB

Video Snake
VS = 75Ω BNC-BNC
VF = BNC-F
VR = BNC-RCA
VC = F-RCA
VP = F-F
VH = RCA-RCA

Length (meters)
3, 5, 8, 15, 30, 50

Other Custom Lengths are available

APPLICATIONS

- ANALOG & DIGITAL VIDEO
- STUDIO TIE LINES
- PATCH CORDS
- RACK WIRING
- SATELLITE HEADENDS
- OB VANS

VAC • 75Ω BNC (RG59) VIDEO CORDS

Our high quality **RG59B/U** 75Ω BNC-BNC cord is perfect for patching, rack wiring or layout between video plant equipment. All models are super flexible and come pre-assembled with 2 color matched cable strain relief boots. Canare cable and connectors offer excellent performance because they are 75Ω impedance matched for cleaner and sharper video resolution.



STANDARD STOCK • 75Ω VIDEO CORDS				
MODEL	Lng.	75Ω Coax Cable	75Ω BNC Crimp Plugs	Color Boot
VAC003F	3ft	LV-61S	BCP-C4B	CB04
VAC006F	6ft			
VAC010F	10ft			
VAC025F	25ft			

COLORS AVAILABLE										
	BLK	BLU	BRN	GRY	GRN	ORN	PPL	RED	WHT	YEL
VAC	■	■	■	■	■	■	■	■	□	■

FEATURES

Canare 75Ω BNC, F or RCA Crimp Plugs

Super Flexible, easy payout & wrap-up

High Density Copper Braid, or Foil + Braid Shields

Variety of Matte Finish Jacket Colors

100% Test and Quality Controlled

Excellent Connector Pull Strength

Color Matching Strain Relief Boots

VIC • 75Ω BNC (8281F) VIDEO CORDS

Canare VIC cords are useful for both inter-rack harness wiring and longer video cable runs. This super flexible **8281F** type pre-made 75Ω BNC-BNC assembly is available in a variety of colors. Our low loss cord offers outstanding video bandwidth performance because all components used are impedance matched for cleaner and sharper video resolution.



STANDARD STOCK • 75Ω VIDEO CORDS				
MODEL	Lng.	75Ω Coax Cable	75Ω BNC Crimp Plugs	Color Boot
VIC010F	10ft	LV-77S	BCP-C77A	No
VIC025F	25ft			
VIC050F	50ft			
VIC100F	100ft			

COLORS AVAILABLE										
	BLK	BLU	BRN	GRY	GRN	ORN	PPL	RED	WHT	YEL
VIC	■	■	■	■	■	■	■	■	○	■

□ = Standard Stock ○ = Special Order

75Ω F CORDS

Premium RF video line cords can now be special ordered using our new **FP-C** series 2GHz crimp connector. Choose from a wide assortment of jacket colors and lengths of Canare standard analog or low loss digital 75Ω Video Coax Cables.



75Ω RCA VIDEO CORDS

RCA video patch cords can now be special ordered. Made with our new **RCAP** series 200MHz crimp connector. Choose from a wide assortment of Canare 75Ω Video Coax Cables. Perfect for **SPDIF** Digital Audio and MultiMedia.



Custom Model Selection Guide

B02B005F BLACK

1st End Connector Type

B = 75Ω BNC Crimp Plug (BCP-P)
 F = 75Ω F Crimp Plug (FP-C)
 R = 75Ω type RCA Crimp Plug (RCAP-C)

75Ω COAX Cable Type

- 01 = L-1.5C2VS
- 02 = L-3C2VS
- 03 = LV-61S
- 04 = LV-77S
- 05 = L-2.5CFB
- 06 = L-3CFB
- 07 = L-4CFB0
- 08 = L-5CFB
- 09 = L-7CFB

Cable Color

BLACK, BLUE, BROWN, GRAY, GREEN, ORANGE, PURPLE, RED, WHITE, YELLOW

Boot

BLANK = 2ea Matching Color CB Boots
 X = No Boots
 S = Other CB Boot Colors

Length (feet)

1, 2, 3, 5, 8, 10, 15, 30, 50, 100
 Other Custom Lengths are available

2nd End Connector Type

B = 75Ω BNC Crimp Plug
 F = 75Ω F Crimp Plug
 R = 75Ω type RCA Crimp Plug
 X = Blunt Cut

		NOMINAL ATTENUATION VALUE								
		1 MHz	10 MHz	50 MHz	100 MHz	200 MHz	400 MHz	700 MHz	900 MHz	1 GHz
L-3C2VS	dB/100 ft	0.5	1.5	3.2	4.7	6.7	9.4	12.5	14.2	14.9
	dB/100m	1.5	4.9	10.4	15.5	21.9	31.0	41.0	46.5	49.0
LV-61S	dB/100 ft	0.4	1.3	2.7	4.1	5.7	8.1	10.7	12.1	12.8
	dB/100m	1.3	4.2	9.0	13.3	18.8	26.6	35.1	39.8	42.0
LV-77S	dB/100 ft	0.3	1.0	2.4	3.3	4.6	6.6	8.6	9.8	10.4
	dB/100m	1.1	3.4	7.8	10.8	15.2	21.5	28.4	32.3	34.0
L-3CFB	dB/100 ft	0.3	1.0	2.5	3.3	4.5	6.5	8.8	10.1	10.6
	dB/100m	1.1	3.2	8.0	10.7	14.7	21.3	28.9	33.0	34.8
L-4CFB	dB/100 ft	0.3	0.9	2.0	2.7	3.8	5.4	7.3	8.4	8.9
	dB/100m	1.0	2.9	6.7	8.9	12.4	17.7	24.0	27.6	29.3
L-5CFB	dB/100 ft	0.3	0.5	1.6	2.2	3.0	4.3	6.0	6.8	7.2
	dB/100m	0.8	1.6	5.3	7.1	9.9	14.2	19.5	22.2	23.7
L-7CFB	dB/100 ft	0.2	0.5	1.2	1.6	2.1	3.1	4.2	4.8	5.1
	dB/100m	0.7	1.6	3.9	5.2	6.9	10.0	13.8	15.7	16.7

VPC 75Ω VIDEO PATCH CORDS

Canare video patch cords are the perfect compliment to our 75Ω video patchbays. Assembled with Canare LV-61S and VWP-C4A plugs, they are impedance matched for 1.4GHz performance.

Precisely cut to length, super flexible and available in a variety of colors including Red, Green and Blue for component analog systems. All video patch cords come with a special color-matched rubber boot to ensure extra long life reliability.



75Ω VIDEO PATCH CORDS				
Model	Lng.	75Ω Coax Cable	75Ω Video Plugs	Color Boot
VPC002F	2ft	LV-61S	VWP-C4A	CB04
VPC003F	3ft			
VPC006F	6ft			

COLORS AVAILABLE										
BLK	BLU	BRN	GRY	GRN	ORN	PPL	RED	WHT	YEL	
■	■	■	■	■	■	■	■	■	■	■

BC BANTAM AUDIO PATCHCORDS

Canare offers a highly flexible, yet extremely rugged premium TT Patchcord usable in all balanced Audio Bantam Patchbays. Carefully assembled using Canare L-4E5C mini Star Quad audio cable and meticulously soldered onto Nickel & Gold Plated TRS Bantam Plugs. Available in 7 Cable jacket Colors and supplied with set of snap in place Color ID Rings.



TRS BANTAM AUDIO PATCH CORDS				
Model	Lng.	Star Quad Audio Cable	Audio Plug	Color Rings
BC003M	1ft	L-4E5C	TRS Bantam	Red, Orn,
BC006M	2ft			Yel, Grn,
BC009M	3ft			Blu, Gry

COLORS AVAILABLE						
BLK	BLU	GRY	GRN	ORN	RED	YEL
■	■	■	■	■	■	■
□ = Standard Stock			○ = Special Order			

GO GUITAR CORDS

These high quality 1/4" guitar/patch cords come in a variety of convenient lengths and colors. All models are meticulously hand soldered using our very flexible, low noise GS-6 instrument cable mated with two premium Canare F-15 1/4" mono phone plugs. Also highly recommended as an Amplifier to Speaker Cabinet lead.



GO PRE-MADE CORDS			
Model	Lng.	Cable	Audio connector 1/4" Phone Plug
GO10F	10ft	GS-6	F-15
GO20F	20ft		
GO25F	25ft		

COLORS		
BLK	BLU	RED
■	■	■

AV COMBO SNAKES

For ENG/EFP/OB operations. Broadcast quality made-to-order A/V combo snakes using flexible Canare A2V1 (pictured), A3V1-FB, A2V2-L, A3V2-FB Audio+Video composite cable.

Each end precisely terminated to your choice of impedance matched 75Ω BNC, F or RCA crimp plugs with Male &/or Female XLR3 Connectors. Contact Canare for all custom snake requirements.



APPLICATIONS

- MICROPHONES
- STUDIO AUDIO TIE LINES
- PATCH CORDS
- RACK WIRING
- SNAKE SYSTEMS
- PA MIXERS

FEATURES

- Super Flexible even in sub-zero weather**
- Rejects EMI, RFI and Handling Noise**
- High Density Copper Braid Shield**
- Variety of Matte Finish Jacket Colors**
- 100% Test and Quality Controlled**
- Excellent Connector Pull Strength**

STAR QUAD

Canare Star Quad is designed for use with microphones but is also excellent for all line-level signals (e.g. mixer to power amps). The 4-conductor Star Quad arrangement cancels electromagnetically induced noise from SCR dimmer packs, fluorescent lighting ballasts and AC power transformers. Handling noise is prevented by use of cotton filler material. Excellent frequency response is maintained due to special irradiated polyethylene insulation which provides a low capacitance dielectric.

Canare Star Quad cable is super flexible. We use large numbers of thin wire strands in both the conductors and overall shield. We extrude a special compound PVC outer jacket that remains pliant at extremely low temperatures with no wait between cold shipping and installation.

Canare pre-assembled Star Quad Professional Microphone audio cords are available in a variety of convenient lengths and matte finish jacket colors. Both ends are meticulously hand soldered using premium Neutrik XLR-3 connectors with black chrome shells and gold plated contact pins.



EC MICROPHONE CORDS

STANDARD STOCK • STAR QUAD AUDIO CORDS				
Model	Lng.	Cable Star Quad	Connector Plug XLR3-Female	Connector Plug XLR3-Male
EC005F	5ft	L-4E6S	Neutrik	Neutrik
EC015F	15ft		NC3FX-B	NC3MX-B
EC025F	25ft		Black Shell	Black Shell
EC050F	50ft		Gold pin	Gold Pin
EC100F	100ft			

COLORS AVAILABLE									
BLK	BLU	BRN	GRY	GRN	ORN	PPL	RED	WHT	YEL
■	■	■	■	■	■	■	■	■	■

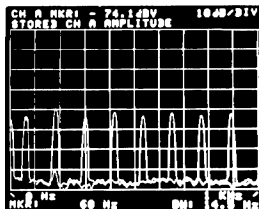

Typical 2 conductor mic cable.

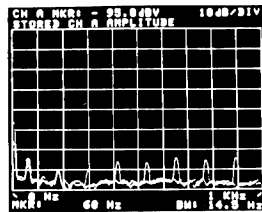

Canare Star Quad cable.

TECHNICAL NOTE The signal generated by a microphone during quiet periods can be very low in level, -70dB to -120dB (0.3 millivolts to 1 microvolt). The cable that must carry this signal to the mixer is very sensitive to Electromagnetic Interference (EMI), Radio Frequency Interference (RFI) and electrostatic coupling of hum and noise. Mechanical vibration, bending, flexing (handling noise) and ambient temperature fluctuations can cause detrimental capacitance changes within the microphone cable. Canare Cables are carefully designed and manufactured to very close tolerances using the highest quality materials available so that low level microphone circuits will not be affected by these outside disturbances. The difference is clearly measurable and audible.

For a more detailed illustration, please request our Technical White Paper: "Evaluating Microphone Cable Performance and Specifications."

12B1N2 35-37	322U-RJR 8	BCJ-TRA-XP3F 21	F-11 20	R300S 34
12B2N1 35-37	322U-RJR1 8	BCJ-TRA-XP3M 21	F-12 20	R380D 34
12C10E3 35-37	322U-RJRU 8-9	BCP-C1 11	F-15 20	R380S 34
12C30E3 35-37	322U-X12F 8-9	BCP-C25F 11	F-16 20	R460C 34
12C50E3 35-37	322U-X1F 8-9	BCP-C32 11	FJ-FPC 14	R460S 34
12J12N1 35-37	322U-X2F 8-9	BCP-C3B 11	FJ-JR 14	R5 18
12J12N12 35-37	32B12MF11 35-37	BCP-C3F 11	FJ-JRU 14	RCAP-C3A 17
12J12N2 35-37	32B12MS 35-37	BCP-C4B 11	FK37-21C 35-37	RCAP-C3F 17
12R30E3 35-37	32B12MSW 35-37	BCP-C4F 11	FK37-22C 35-37	RCAP-C4A 17
12R50E3 35-37	32B12MWF11 35-37	BCP-C41 11	FK37-31S 35-37	RCAP-C4F 17
12S1N2 35-37	32C01MR2M22 35-37	BCP-C51 11	FK37-32S 35-37	RCAP-C53 17
12S2N1 35-37	32C10MR2 35-37	BCP-C53A 11	FP-C3 15	RCAP-C5A 17
161U-BJR 8	32C30MR2 35-37	BCP-C5B 11	FP-C3F 15	RCAP-C5F 17
161U-BJRU 8-9	32C50MR2 35-37	BCP-C5FA 11	FP-C4 15	RCAP-C77 17
161U-FJR 8	32S1MS2 35-37	BCP-C55A 11	FP-C4F 15	RJ-BCJR 16
161U-FJRU 8-9	32S2MS2 35-37	BCP-C71A 11	FP-C5 15	RJ-BCJRU 16
161U-RJR 8	3VS03-3C 38	BCP-C77A 11	FP-C51 15	RJ-R 16
161U-RJR1 8	3VS05-3C 38	BCP-C7FA 11	FP-C53A 15	RJ-RU 16
161U-RJRU 8-9	4S11 31	BCP-LC3F 11	FP-C55A 15	TC-1 18
161U-X12F 8-9	4S6 31	BCP-LC5F 11	FP-C5F 15	TCD-1DB 18
161U-X1F 8-9	4S8 31	BCP-TA 13	FP-C71A 15	TCD-35CA 18
161U-X2F 8-9	4VS03-3C 38	BET-08 19	FP-C7FA 15	TCD-3C 18
16B1F2 35-37	4VS05-3C 38	BET-12 19	G010F 40	TCD-451CA 18
16B2F1 35-37	5VS03-3C 38	BN1002A 15	G020F 40	TCD-4C 18
16C10E3 35-37	5VS05-3C 38	BN1003A 15	G025F 40	TCD-5CF 18
16C30E3 35-37	8B1N2 35-37	BN1004A 15	GS-4 30	TCD-7CA 18
16C50E3 35-37	8B2N1 35-37	BN1005A 15	GS-6 30	TS100E 18
16J12F1 35-37	8C10E3 35-37	BN1012A 11	I/U-7/16 13	TS-31C 18
16J12F12 35-37	8C30E3 35-37	BN1030 15	L-1.5C2VS 24	TS-3C 18
16J12F2 35-37	8C50E3 35-37	BN1041 15	L-2B2AT 29	TS-4C 18
16R30E3 35-37	8J12N1 35-37	BN1043 11	L-2E5 29	TS-5C 18
16R50E3 35-37	8J12N12 35-37	BN1051 11	L-2T2S 29	TS-V3C 18
16S1F2 35-37	8J12N2 35-37	BN7002 11	L-2.5CFB 22	V3-1.5C 25
16S2F1 35-37	8R30E3 35-37	BN7003A 11, 15, 17	L-3C2VS 24	V3-3C 25
201U-DVJS 6-7	8R50E3 35-37	BN7015A 11, 15, 17	L-3CFB 22	V3-3CFB 23
201U-DVJW 6-7	8S1N2 35-37	BN7016 11, 15, 17	L-4CFB 22	V3-4CFB 23
241U-DVJS 6-7	8S2N1 35-37	BN7021A 11, 15	L-4E3-12P 28	V3-5C 25
241U-DVJW 6-7	A2C3 33	BN7022 11	L-4E3-16P 28	V3-5CFB 23
242U-DVJS 6-7	A2V1 32, 40	BN7026 11	L-4E3-24P 28	V4-1.5C 25
242U-DVJW 6-7	A2V2-L 32, 40	BN7029B 11	L-4E3-2P 28	V4-3C 25
244U-DVJS 6-7	A3V1-FB 32, 40	CB03 19	L-4E3-4P 28	V4-3CFB 23
244U-DVJW 6-7	A3V2-FB 32, 40	CB04 19	L-4E3-8P 28	V4-4CFB 23
24B12MS 35-37	B11014D 11, 17	CB05A 19	L-4E4-12AT 28	V4-5C 25
24B12MSW 35-37	B11015D 11, 17	CRS-02 19	L-4E4-16AT 28	V4-5CFB 23
24C10E3 35-37	B11016D 11, 17	D403-AT 33	L-4E4-24AT 28	V5-1.5C 25
24C30E3 35-37	B11020C 11, 17	DA202 33	L-4E4-2AT 28	V5-3C 25
24C50E3 35-37	B75004 11, 15, 17	DA202-2P 33	L-4E4-4AT 28	V5-3CFB 23
24R30E3 35-37	BC003M 40	DA202-4P 33	L-4E4-8AT 28	V5-4CFB 23
24S1MS2 35-37	BC006M 40	DA202-8P 33	L-4E5AT 27	V5-5C 25
24S2MS2 35-37	BC009M 40	DA202AT 33	L-4E5C 27	V5-5CFB 23
261U-DVJS 6-7	BCJ-DC 13	DA206 33	L-4E6AT 27	VAC003F 39
261U-DVJW 6-7	BCJ-J 13	DVJ-S 4-5	L-4E6S 27	VAC006F 39
262U-DVJS 6-7	BCJ-JR 12	DVJ-W 4-5	L-5CFB 22	VAC010F 39
262U-DVJW 6-7	BCJ-JRU 12	ECO05F 41	L-7CFB 22	VAC025F 39
264U-DVJS 6-7	BCJ-R/1 12	ECO15F 41	LP-1 6	VIC010F 39
264U-DVJW 6-7	BCJ-RU 12	ECO25F 41	LV-61S 24	VIC025F 39
322U-BJR 8	BCJ-VWP 5	ECO50F 41	LV-77S 24	VIC050F 39
322U-BJRU 8-9	BCJ-XJ-A10TR 21	EC100F 41	MR202-12AT 29	VIC100F 39
322U-FJR 8	BCJ-XJ-TRA 21	F-09 20	MR202-16AT 29	VJ2-E20 6-7
322U-FJRU 8-9	BCJ-XP-TRA 21	F-10 20	MR202-24AT 29	VJ2-E24-1U 6-7

TECHNICAL TERMS ABBREVIATION TABLE

ABS Acrylonitrile-Butadiene-Styrene	MΩ Mega Ohm
AC Annealed Copper	mΩ Milli Ohm
AT Aluminum Tape	nS Nano Second
AWG American Wire Gauge	PE Polyethylene
dB Decibel	pF Pico Farad
ft Feet	PPO Polyphenylene Oxide
in Inch	PTFE Polytetrafluoroethylene
IPE Irradiated Polyethylene	PVC Polyvinylchloride
m Meter	RL Return Loss
MHz Megahertz	TAC Tinned Annealed Copper
mil One Thousandth of an inch	V Volt
mm Millimeter	VSWR Voltage Standing Wave Ratio
mV Millivolt	Ω Ohm